

Orientalmotor

New 0.72° Stepper Motor and Driver Packages

RKII Series

FLEX Built-in controller type
Pulse input type

BEST

PERFORMANCE & PRICE



Introducing a re-invented affordable high performance stepper motor.

BEST

PERFORMANCE & PRICE

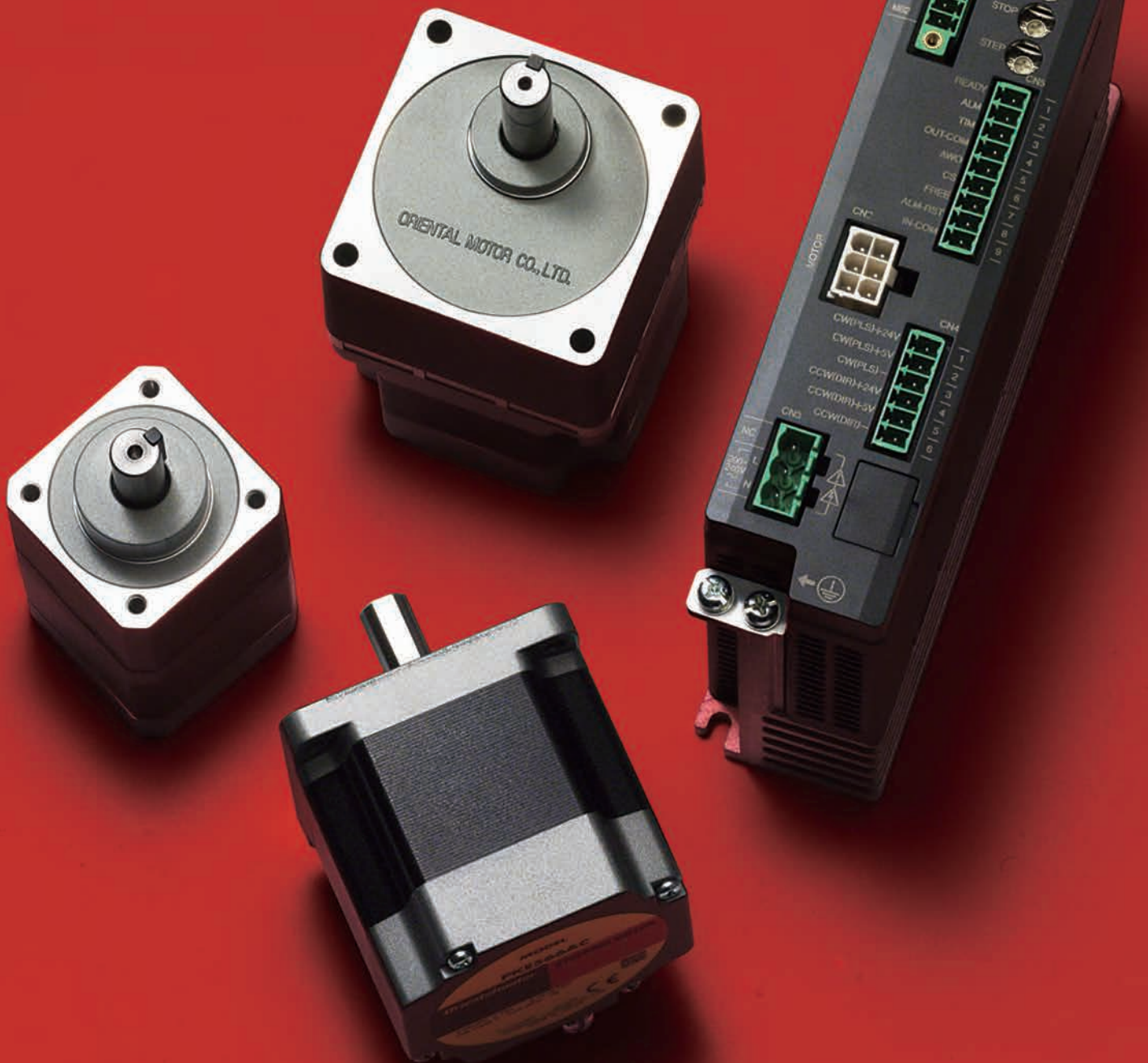

A highly reliable stepper motor that is too user-friendly to resist.

SAVE

PRICE & ENERGY

- Compact size, yet low price Page 4
- Reduction power consumption and running cost ... Page 5



EASY

CONNECTION & SYSTEM

- Easy wiring Page 6
- Easy selection Page 6
- 2 types of drivers are available Page 7

HIGH

PERFORMANCE & RELIABILITY

- High accuracy Page 10
- Multiple step angle selections Page 11
- Various kinds of protective functions (Alarm) Page 11

New 0.72° Stepper Motor and Driver Packages

RKII Series

Price

High-efficiency with Low Price

While achieving a significant improvement in motor performance, driver operations and functions, compared to conventional products, the **RKII** Series has a new, low price.

Space Saving

Slim and Compact

This new driver has been created by re-arranging the internal components, optimizing the usage of the size within the driver. In addition, drivers can be installed side by side, reducing a significant amount of space.

- When drivers are installed in contact with each other, the allowable ambient temperature range is 0 to 40°C

Slim & compact driver

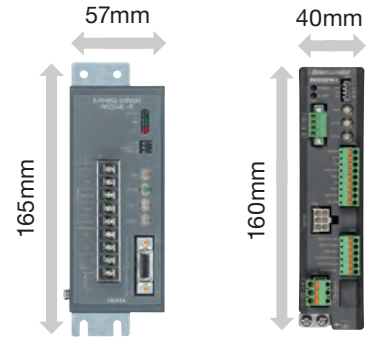

Conventional Model
RK Series Driver

Installation Area
9405 mm²
(165x57=9405)

RKII Series Driver

Installation Area
6400 mm²
(160x40=6400)

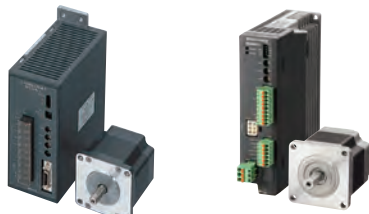

Conventional Model:
RK Series
□ 60 mm Standard Type

RKII Series
Pulse Input Type
□ 60 mm Standard Type

- For price and lead time, please contact the nearest Oriental Motor office, or visit the Oriental Motor website.

Multiple units can be installed in coherently with each other.

Conventional Model:
RK Series Driver

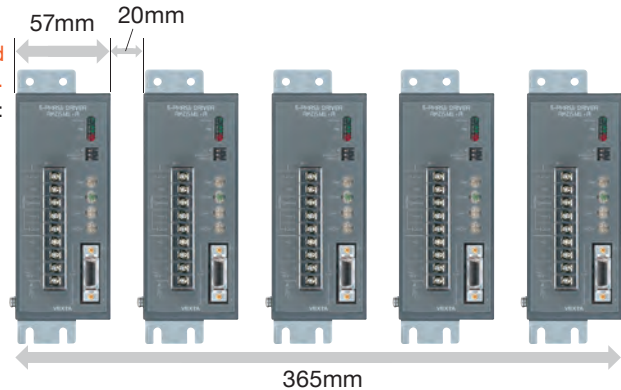

RKII Series Driver

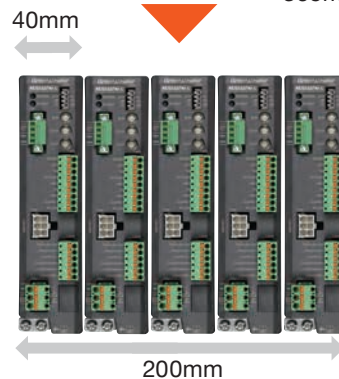

Installation Width
45% Reduction

ADVANTAGE
High-efficiency and compact size, yet cost down.

ADVANTAGE
Less space and costs for control board.

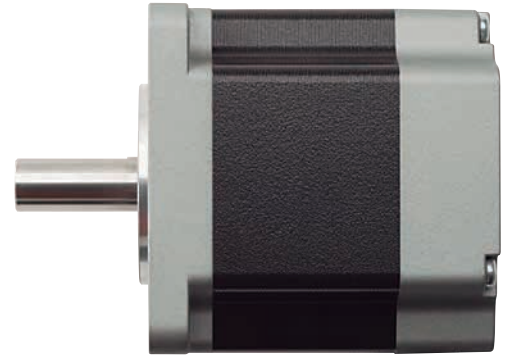

High Efficiency

Reduces power consumption by up to 47%

By optimizing the motor material, 47% of the power consumption has been reduced. This results in the decrease of electricity and CO₂ emission. In addition, with lower heat generated by the motor, there is a lesser requirement of fans or radiation plate.

Lower Heat Generation

Continuous Operation is Achieved

By utilizing high-efficient technology, continuous operation is achieved due to the reduction of motor heat.

● Power Consumption Comparison

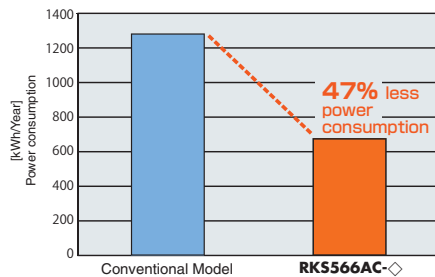

Operating Condition
 · Spin speed : 1000 r/min
 · Load torque: 0.47 N·m
 · Operating time: 24 hours
 (Operation 70%, Stand-by 25%, Stop 5%)
 365 days/year

● Motor Surface Temperature Comparison under the Same Conditions

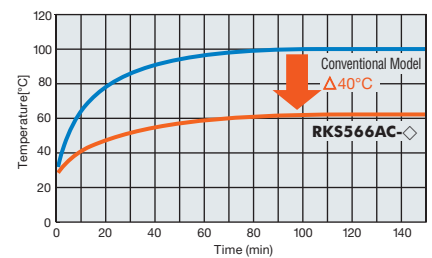

● Power Consumption Comparison

Items	Conventional Model	RKS566AC-◇	Comparison	
			Value	Change
Power consumption during operation [W]	204	106	98 W	Reduced by 48%
Power consumption during stand-by [W]	14	13	1 W	Reduced by 7%
Power consumption [kWh/year]	1281	678	603 kWh/year	Reduced by 47%
CO ₂ emission equivalent to power consumption ※ [kg/year]	533	282	251 kg/year	Reduced by 47%

※ : Conversion rate: 0.416 kg/kWh

● Distribution of temperature (shown on thermography)



ADVANTAGE
 With the maximized motor performance, it is easy to achieve high efficiency and cost savings.

ADVANTAGE
 Less effort for temperature control.

EASY

CONNECTION & SYSTEM

Easy to wire, easy to select.

Wiring

Easy Wiring

The new I/O connector does not require a screw, eliminating the need for soldering or a special crimping tool. The motor connector can be connected easily by using a dedicated cable. This will reduce wiring time, maintenance and prevent mis-wiring.

● Motor Connector Wiring

- No screw tightening
- Wiring time reduction
- Reduce problems caused by mis-wiring

● I/O Connector Wiring

- No soldering
- No crimping tools
- Wiring time reduction
- Less maintenance

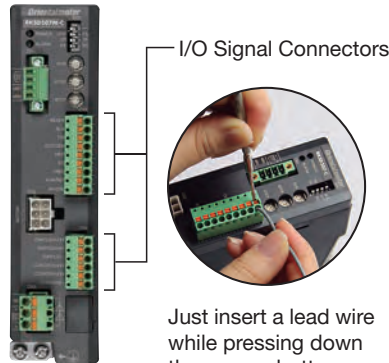

I/O Signal Connectors

Just insert a lead wire while pressing down the orange button with a screwdriver or pointed object.

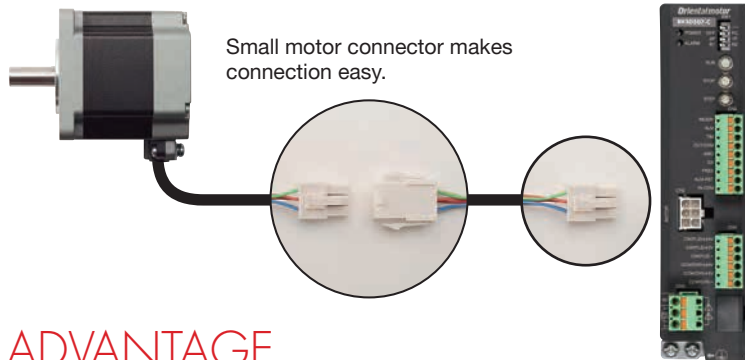

Small motor connector makes connection easy.

Selection

Easy Selection

● Free Motor Selection Service for Customers:

Send us a motor selection inquiry via our website, fax or e-mail.

ADVANTAGE

The redesigned driver is more compact and allows an installation close to other drivers. The wiring has been simplified.

Two types of drivers are available.

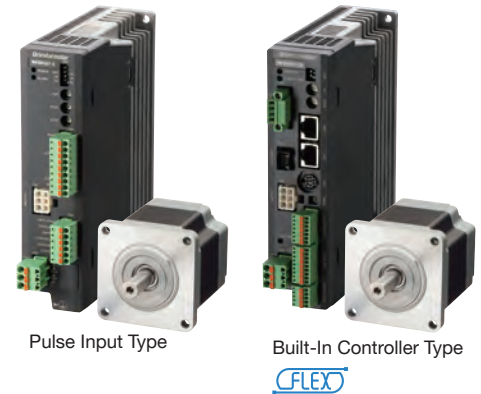

Driver

Pulse Input Type
Built-In Controller Type

Select the control method in accordance with your operation system.

Pulse Input Type

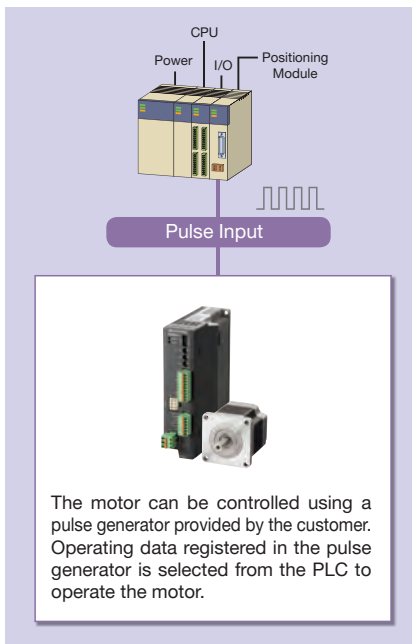

Built-In Controller Type

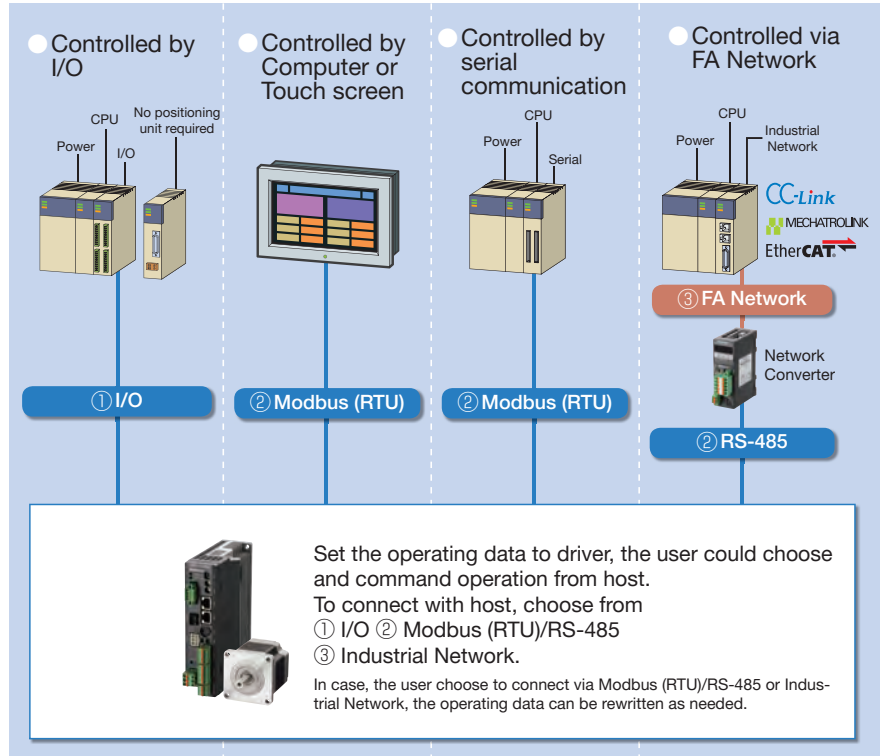

How to connect (Example: Refer to P. 8 and P. 9)

- ① I/O: The function of a built-in pulse generator lets you build an operation system by connecting directly to a PLC. Since no separate pulse generator is required, the drivers of this type save space and simplify systems.
- ② Modbus (RTU)/RS-485: Through RS-485 communication, you can set operating data and parameters and input operation commands. A maximum of 31 drivers can be connected to one serial unit. There is also a function for simultaneously starting multiple axes. The unit also has a feature for starting multiple axes simultaneously. The unit supports the Modbus (RTU) protocol, which makes it easy to connect a PLC or similar device to the driver.
- ③ Industrial Network: By using a Network Converter (sold separately), you can use EtherCAT communication, CC-Link communication and MECHATROLINK communication. Over these links, operating data and parameters can be set, and operation commands can be sent to the driver.

Built-In Controller (Stored Data) Type

The burden on the programmable PLC is reduced because the information necessary for motor operations is built into the driver. This simplifies the system configuration for multi-axis control. Set with control module (sold separately), data setting software or RS-485 communication.

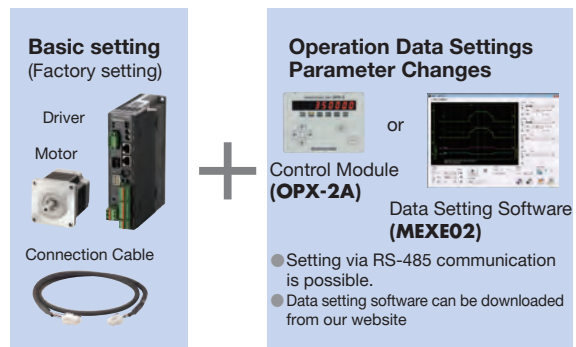

ADVANTAGE
Connects to a Wide Variety of Host Systems.

EASY

CONNECTION & NETWORK

Built-In Controller Type compatible with FLEX.

Example of connection and control with the Built-In Controller Type. [FLEX](#)

I/O Control

Using a Switch Box

Operating data is set in the driver and the motor can be started or stopped simply by connecting a switch you have on hand. Control can be performed easily without using a PLC.

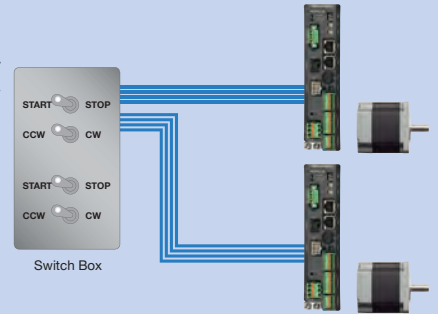

Simple Control Low Cost

Using PLC (No positioning control module is required)

When using PLC, you can built an operation system by connecting directly to an I/O Unit. A positioning unit is not necessary on the PLC side therefore space is saved and the system is simplified

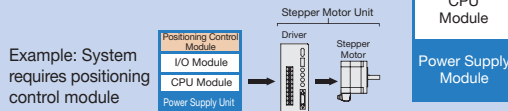

Simple Control Low Cost Space Saving

Using PLC and a Touch Screen

Normally, the motor is started and stopped with I/O. Changing the operating data settings and displaying the monitors and alarms is performed with the touch panel using Modbus (RTU) communication. When there is a lot of setup work, changes can be easily performed on the touch screen, and the burden of creating ladders is reduced.

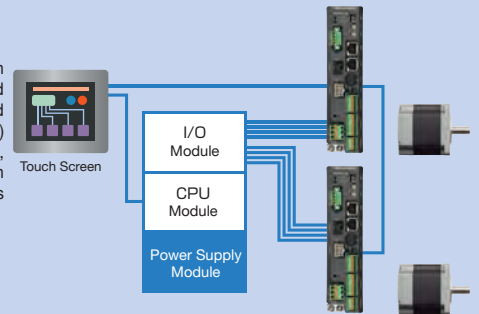

Simple Control Suitable for one or more products

Network Control

EtherCAT Control/CC-Link Control/MECHATROLINK Control

EtherCAT communication, CC-Link communication and MECHATROLINK communication are available by using network converter (sold separately). Operating data and parameters can be set and operation commands can be input using various communication methods. Also it shortens the design time.

- Multi-axis control with simple host.
- Can be connected with different types of network.
- Able to send information to a group of slaves at the same time.
- EtherCAT, MECHATROLINK: 16 axes max
- CC-Link: 12 axes max

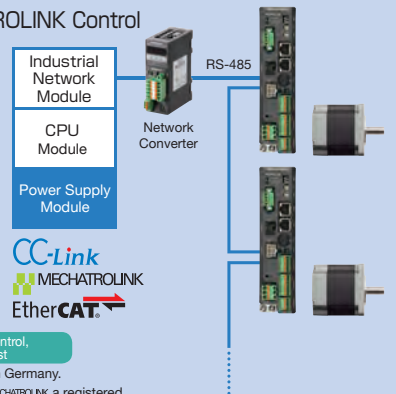

Simple Control Simple Wiring Multi-axis control, lower cost

● EtherCAT is a registered trademark licensed by Beckhoff Automation in Germany.
 ● CC-Link is a registered trademark of CC-Link Partner Association. ■ MECHATROLINK a registered trademark of MECHATROLINK Members Association.

FLEX **FLEX** is a generic name of the products which support Industrial Network control via I/O control, Modbus (RTU) control and network converter.



Built-In Controller Type
FLEX

Modbus (RTU) Control

● Modbus is copyright of Schneider Automation Inc.

Modbus (RTU) control via PLC

RS-485 communication can be used to set operating data, parameters and input operation commands. A maximum of 31 drivers can be connected to one serial unit. There is also a function for simultaneously starting multiple axes. The motor has a function that enables multiple shafts to be started simultaneously. The protocol supports Modbus (RTU), enabling connection with devices such as touch-screen panel computers and PCs.

Simple Control

Simple Wiring

Compatible with serial unit of several manufactures

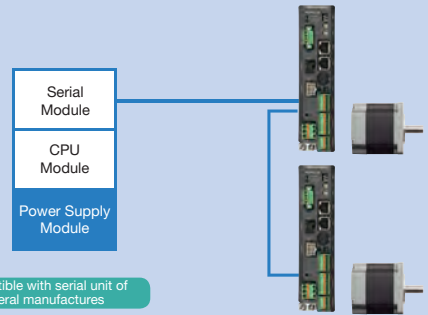

Modbus (RTU) control via PC

Operating data, parameters and input operation commands can be input via RS-485 communication board into PC. It is also suitable for PC Facility Use.



Simple Control

Simple Wiring

Motor Control by PC

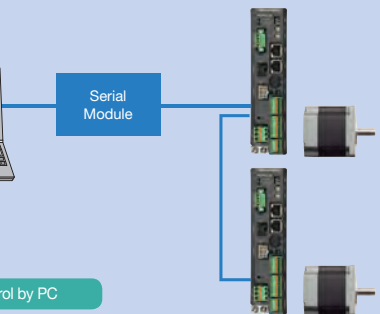

Simple connect to Touch Screen

Direct connection to touch screen is available via Modbus (RTU) communication. Operating data, parameters, alarm record and trial operation can be controlled without PLC.

Use touch screen instead of switch



Touch Screen

※ Pro-face (Digital Electronics Corporation) provides exclusive templates for Oriental Motor "Cockpit". For more detail, please refer to Digital Electronics Corporation's website.

Simple Control

Simple Wiring

System Simplification

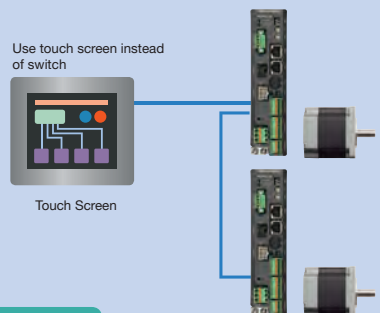

Introduction of Features

Group Sending Function

The group sending function simultaneously starts the multi-axis via Modbus (RTU) or Industrial Network.

Group some drivers, the axes then send operation command to main driver, other drivers in the same group will start operation simultaneously

- Modbus (RTU): Simultaneous start, change of moving angle or speed, monitor are possible.
- Industrial Network: Simultaneous only

● Modbus (RTU) Communication

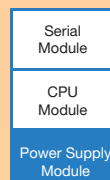

Multi-axis simultaneous starting is possible

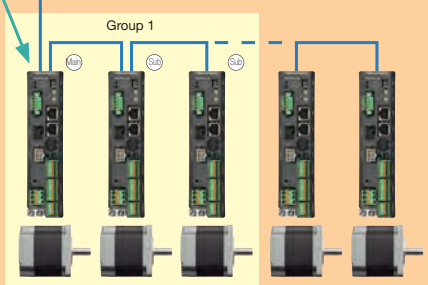

ADVANTAGE
Built-in controller type is compatible with several kinds of system or network.

HIGH

PERFORMANCE & RELIABILITY

Performance and function to enhance reliability.

High Accuracy

High Accurate Positioning

Positioning accuracy of the **RKII** Series is $\pm 0.05^\circ$ (± 3 arc min). When the **RKII** Series is used with a ball screw as shown in the below drawing, the stopping accuracy becomes $\pm 1.4 \mu\text{m}$. The accuracy of the normal ground ball screw is $\pm 10 \mu\text{m}$, thus the accuracy is high enough for positioning operation.

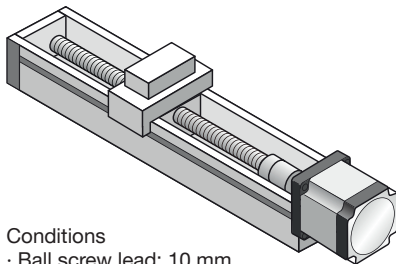

Conditions

- Ball screw lead: 10 mm
- Motor to be used: **RKII** series

Stopping Accuracy $\pm 1.4 \mu\text{m}$

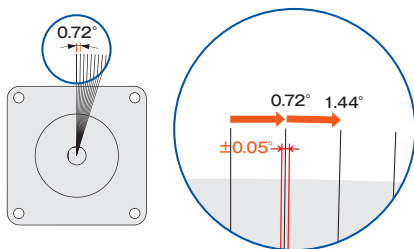

Positioning Accuracy $\pm 0.05^\circ$

ADVANTAGE
High accuracy in positioning $\pm 0.05^\circ$.

High Torque

Compact and High Torque

The **RKII** Series is compact and produces high torque. The torque of the 42 mm frame size model has increased 50%. This contributes to a reduction in positioning and move time. The series includes 60 mm and 85 mm framesize models to cover a wide torque range.

- Note that for 60 mm and 85 mm frame size models, the torque is equivalent to the conventional model.

● Torque Comparison (□ 42 mm)

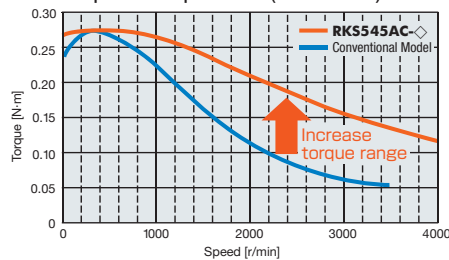

● Torque Comparison by Operating Current

● Torque Comparison by Operating Current

In case of **RK5566AC**-◇

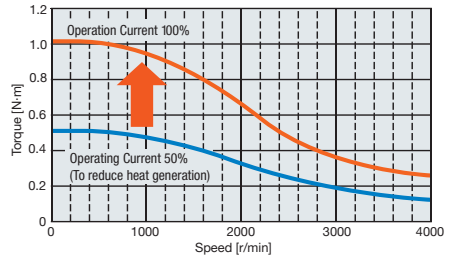

● Comparison of Cycle Time (between deferent current of electricity)

In case of **RK5566AC**-◇

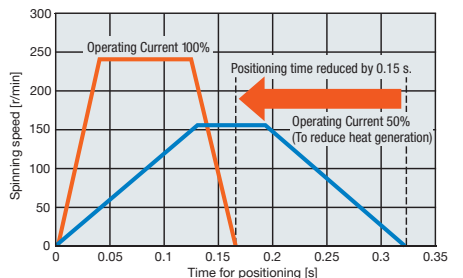

Operating Conditions

- Moment of load inertia: $4 \times 10^{-4} \text{ [kg} \cdot \text{m}^2]$
- Load torque: 0.2 [N·m]
- Traveling Amount: 180°
- Safeness rate: 2

ADVANTAGE
Shorten time for positioning.

ADVANTAGE
Improve cycle time of machinery.

Low Vibration

Digital controlled driver

Utilizing a full-time microstepping driver controlled by a digital system improves the vibration characteristics of the 0.72° stepper motor. Current control is also done by a high specification digital CPU. This model uses PWM control instead of PAM control resulting in a sinusoidal wave form in each phase, significantly reducing vibration.

● Current Waveform in Motor (theoretical figure)

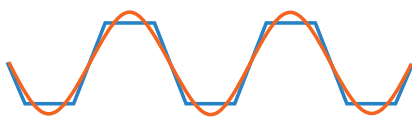

— RKII series: sinusoidal wave
— Conventional products: trapezoidal wave

Current in the motor is changed from trapezoidal wave to sinusoidal wave, which resulted in less vibration.

● Vibration Characteristics Comparison

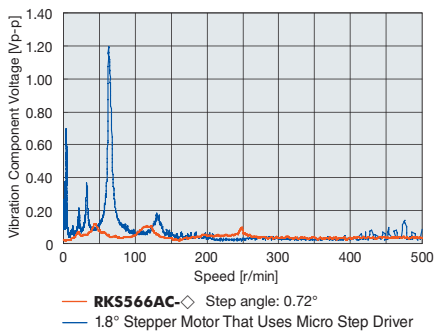

— RKS566AC - Step angle: 0.72°
— 1.8° Stepper Motor That Uses Micro Step Driver

ADVANTAGE
Vibration has been reduced drastically.

Resolution

Step angle can be set easily

For pulse input type, 32 step angles can be selected. To easily upgrade from a 1.8° stepper motor, use the step angle setting switch to match the existing input pulses to the desired output speed and position. There is no software or control module required.

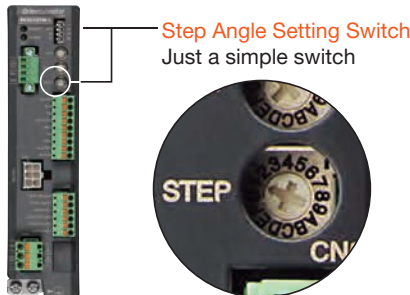

For built-in controller type, the value can be between 200 p/r - 200,000 p/r. Setting can be done by a Control module, software or RS-485 communication.

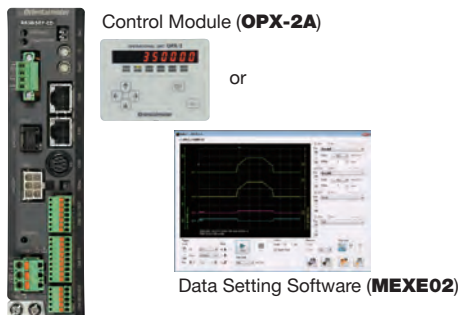

ADVANTAGE
Optimal resolutions can be selected.

Protective Function

Various kinds of protection are installed

Many types of protection functions are integrated into the driver. A blinking LED (blink count determines alarm type) indicates when an alarm is triggered.

(Example of alarm)

- Main circuit overheating
- Overvoltage
- Command pulse error
- Overcurrent
- Undervoltage
- Electrolytic capacitor error
- EEPROM error
- CPU error
- Automatic electromagnetic brake control error

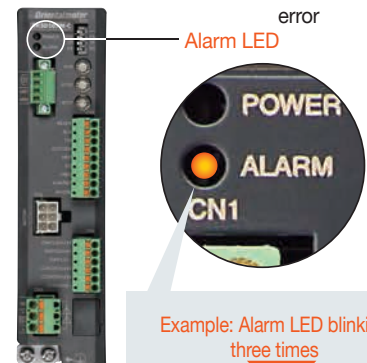

Example: Alarm LED blinking three times



Overvoltage alarm

[Causes]

- Power supply voltage exceeded the permissible value.
- A large inertial load was stopped suddenly or lifted or lowered.

ADVANTAGE
Check troubles with protection function.





● List of drivers and motors

Driver Type	Motor Type	Frame Size	Electro-magnetic Brake	Power Input
Built-in Controller Type  	Standard Type	42 mm 60 mm 85 mm	●	Single Phase 100-120 VAC Single Phase 200-240 VAC
	Standard Type with Encoder	42 mm 60 mm 85 mm	—	
	TS Geared Type PS Geared Type Harmonic Geared Type	42 mm 60 mm 90 mm	●	

Driver Type	Motor Type	Frame Size	Electro-magnetic Brake	Power Input
Pulse Input Type 	Standard Type	42 mm 60 mm 85 mm	●	Single Phase 100-120 VAC Single Phase 200-240 VAC
	TS Geared Type PS Geared Type Harmonic Geared Type	42 mm 60 mm 90 mm	●	

● List of Standard Type, Geared Type and Features

*We provide encoder installed model, but only for the built-in controller models.

Type	Features	Permission Torque, Maximum Torque (N·m)	Backlash (arc min)	Basic Resolution (°/pulse)	Output Shaft Speed (r/min)
Standard Type  with Encoder*	<ul style="list-style-type: none"> Basic model of the RK II series with Encoder For encoder installed model, functions for monitoring positioning data, detecting positioning gap are available. Resolution of encoder installed: 500 p/r. 	Maximum holding torque 6.3	—	0.72	6000
Backlash-less TS Geared Type (Spur Gear Mechanism) 	<ul style="list-style-type: none"> High torque (Double of existing products) A wide variety of reduction gear ratios, high-speed operations Gear ratio types 3.6, 7.2, 10, 20, 30 	Permission torque, Maximum torque 25 45	10	0.024	833
Backlash-less PS Geared Type (Planetary Gear Mechanism) 	<ul style="list-style-type: none"> Less backlash (comparing with existing products) High permission torque, maximum torque A various reduction gear ratio lineup make easy to detect angle Center shaft Gear ratio types 5, 7.2, 10, 25, 36, 50 	Permission torque, Maximum torque 37 60	7	0.0144	600
Non backlash Harmonic Geared Type (Harmonic Drive)  	<ul style="list-style-type: none"> Longer mechanical life (Double of existing products) Higher torque (1.3 times of existing products) High accuracy in positioning High permission torque, maximum torque High reduction ratio, high resolution Center shaft Gear ratio types 50, 100 	Permission torque, Maximum torque 52 107	0	0.0072	70

Note

- Above values are for reference only. Values can be changed depending on setting angle or reduction ratio.
- Harmonic drive and  are registered trademarks of Harmonic drive systems Inc or trademarks.

Geared motors offered by Oriental Motor, quick reference chart for performance and price.



Features of New Lineup

NEW Standard Type with Encoder (Built-in controller type only)

Encoder installed models make it possible to monitor the present position and detect for errors.



● Positioning monitor

This feature can be used to detect the position of the motor, for instance, compare the commanded position, to confirm normal operation.

● Return-to-Home operation by using Z-phase signal

Z-phase signal can be utilized to home return operation. Using Z-phase signal, the home return point will be detected with higher accuracy than single use of the home return sensor.

● Detecting for errors

The encoder will compare command position and encoder-count, if deviation exceeds set value a STEPOUT signal will be output. An alarm signal for abnormality is also available.

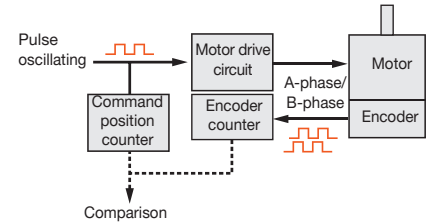

TS Geared Type

This geared type is made with a simple spur gear design. The torque and speed have been improved.



● Mechanism

Because of its high accuracy, this type has the same level of accuracy when compared to our tapered (TH) type without the added cost of tapering.

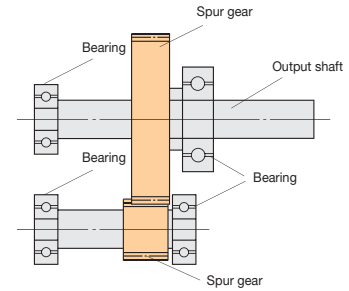
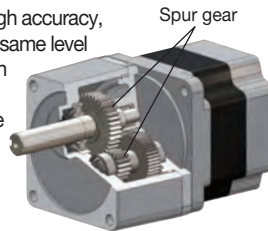

● Torque and speed are improved (compare with existing type)

The TS geared type realizes the improvement of permissible torque and at the same time, it can exert its maximum torque. The rated input speed is increased to 3,000 r/min, and the permissible speed range of the output shaft has been significantly increased as well. The motor allows for higher torque and shortens the time for positioning, because the maximum torque range can be used for acceleration/deceleration.

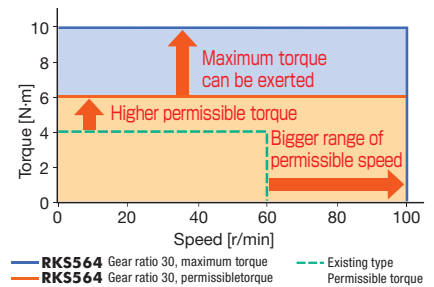

PS Geared Type

The PS gear mechanism is comprised primarily of a sun gear, planetary gears and an internal tooth gear. The planetary gears design allows for higher output torque.



● Mechanism

There are gears inside used to distribute torque, which allows for higher torque than a spur gear design. The PS gear uses a higher accuracy gear design which provides for a lower backlash when compared to a spur gear design.

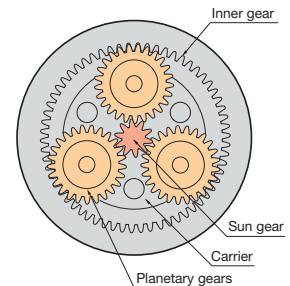

● Reduce backlash (Compare with existing type)

Optimal design of gears reduces backlash. (Except: □ 42 mm)
Positioning with higher accuracy is possible.

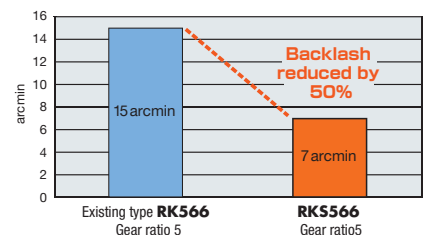

Harmonic Geared Type

The mechanical life, permissible torque and maximum torque are improved (compare with conventional model).



● Improved rated life time (Twice the length of conventional models)

The rated life time has been increased from 5,000 hours (conventional models) to 10,000 hours. (Except □ 42 mm)

[Condition for rated life time]
 Torque : Permissible torque
 Type of load : Uniform load
 Input speed : 1,500 r/min
 Radial load : Permissible radial load
 Axial load : Permissible axial load

● Structure

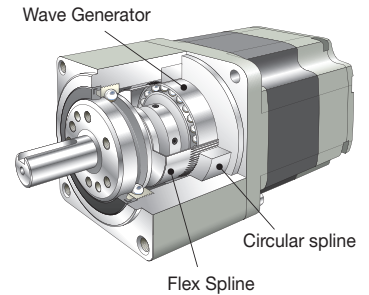

● High torque

With more permissible and maximum torque available, more load can be handled with the same size geared motor.

Comparison of specification

Products name	RKS564AC -HS100-◇	Conventional model
Permissible torque N·m	10	8
Maximum torque N·m	36	28
Gear ratio	100	
Lost motion (Load torque)	0.7 arc min or less (± 0.39 N·m)	

Comparison of torque characteristics

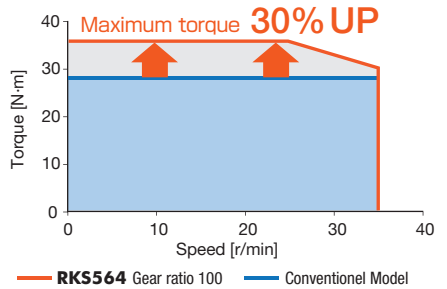
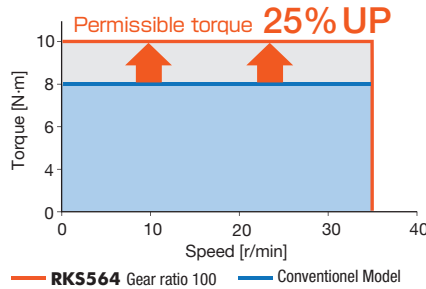

● Surface Installation of load is available

This type permits installation of load directly on the rotating surface integrated with the shaft. (Except: □ 90 mm)

Appearance and Installation
 Example: This surface rotates with the shaft

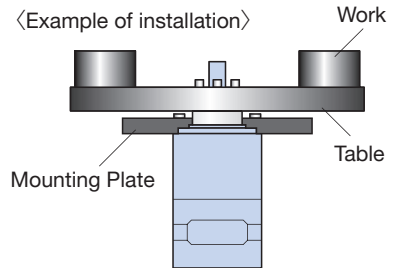

Tapped holes are provided on the rotating surface for load installation

Application: Index Table

This type not only reduces the number of parts/processes, but also improves reliability. They are also suitable for operating loads that receive moment loads.

〈Example mechanism〉

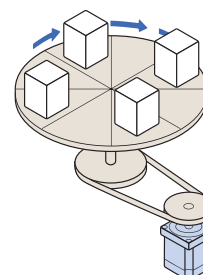

〈Surface mounting〉

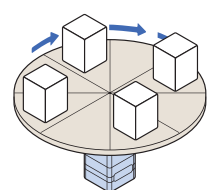



Advantage of geared motor

Using geared motors bring the user many advantages, such as speed reduction, high torque and high resolution.

The motor can drive a large inertial load

If compared with a standard motor, the geared motors can drive larger inertial loads, because it's permissible load moment of inertia increases with the square of reduction ratio.

Comparison of load moment of inertia

	Motor Type	Motor product name	Load moment of inertia (10 times of Rotor Inertia)	Diameter of inertial load (Thickness: 20 mm, material: Aluminum)	Speed range
	Standard Type	RKS564AC -◇	1.6×10^{-4} kg · m ²	72 mm	0 ~ 6,000 r/min
	PS Geared Type (Gear ratio 5)	RK-S566AC-PS5 -◇	67.5×10^{-4} kg · m ²	187 mm	0 ~ 600 r/min

Damping characteristic at starting/stopping will be improved.

When the motor works under large inertial loads or needs to accelerate/decelerate in a short time, it is better to use the geared motor than the standard motor. Because it can reduce damping it can also increase stability. The geared motor is suitable for work that requires to position a large load (i.e. index table, arm) in a short time.

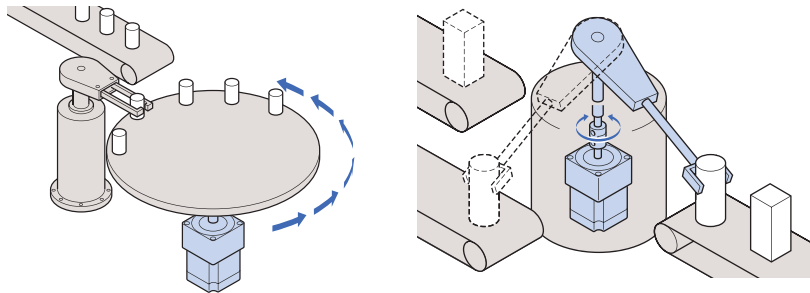

High stiffness, not twisting easily.

The geared motor has a high stiffness and it cannot be twisted easily. It is not profoundly affected by changes of load torque (compared with standard motor).

Application: Lifter

The geared motor can stop with high accuracy even for vertical applications if the load or work changes.

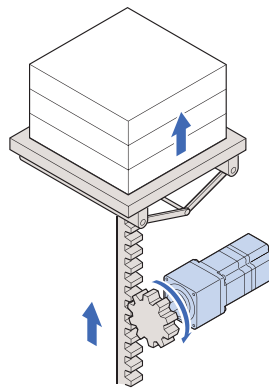

Application: Security Camera

The motor will hold the load even if shaken by a strong wind.

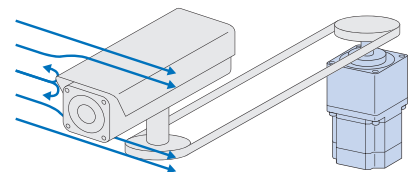

Downsizing

If comparing the standard motor and the geared motor which have similar maximum holding torque, the setting angle of the geared motor is smaller than the standard motor. By comparing the two, the geared motor allows for a small area, saving space, allowing for downsizing.

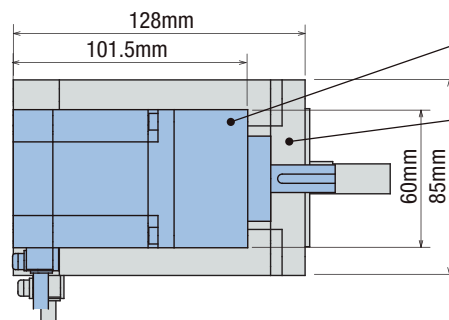

PS Geared Motor

RKS564AC-PS25-◇ Weight: 1.4 kg, TH=8 N·m

Standard Motor

RKS5913AC-◇ Weight: 4.1 kg, TH=6.3 N·m

※ TH means "Holding torque"

System Configuration

Built-In Controller Package Standard Type with Electromagnetic Brake

An example of a system configuration when used with either I/O control or RS-485 communication.

- *1 Not supplied.
- *2 Only with the type supplied with a connection cable
- *3 To be provided as necessary

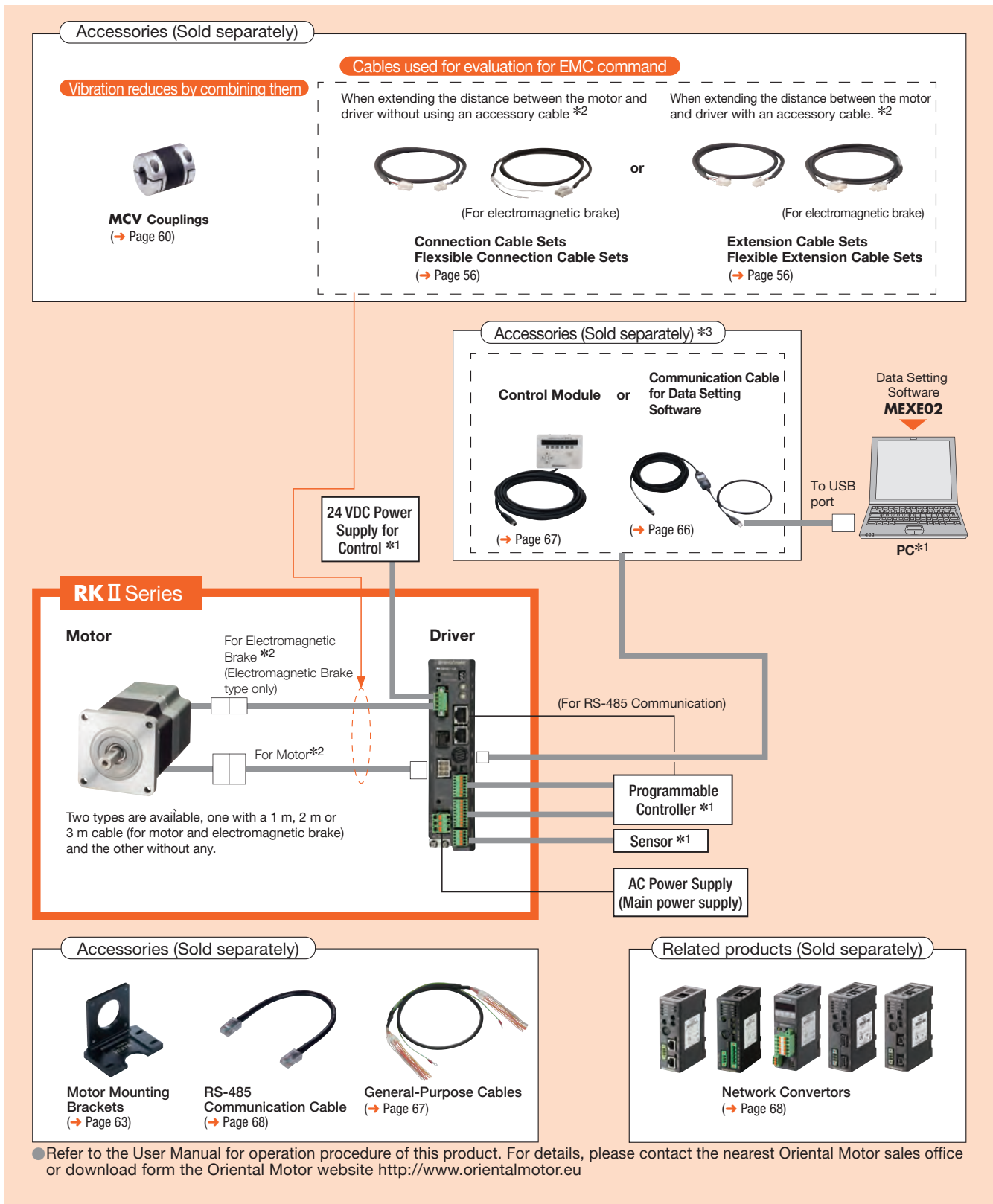

System Configuration Example

RK II series	+	Sold separately		
		Motor Mounting Bracket	Flexible Coupling	General-Purpose Cable (1m)
RKS566MCD-3		PAL2P-5	MCV251010	CC16D010B-1

● The system configuration shown above is an example. Other combinations are available.

System Configuration

Pulse Input Type/Standard Type with Electromagnetic Brake

A single-axis system configuration with the controller **SCX11** Series.

*1 Not supplied

*2 Only the model includes connecting cable

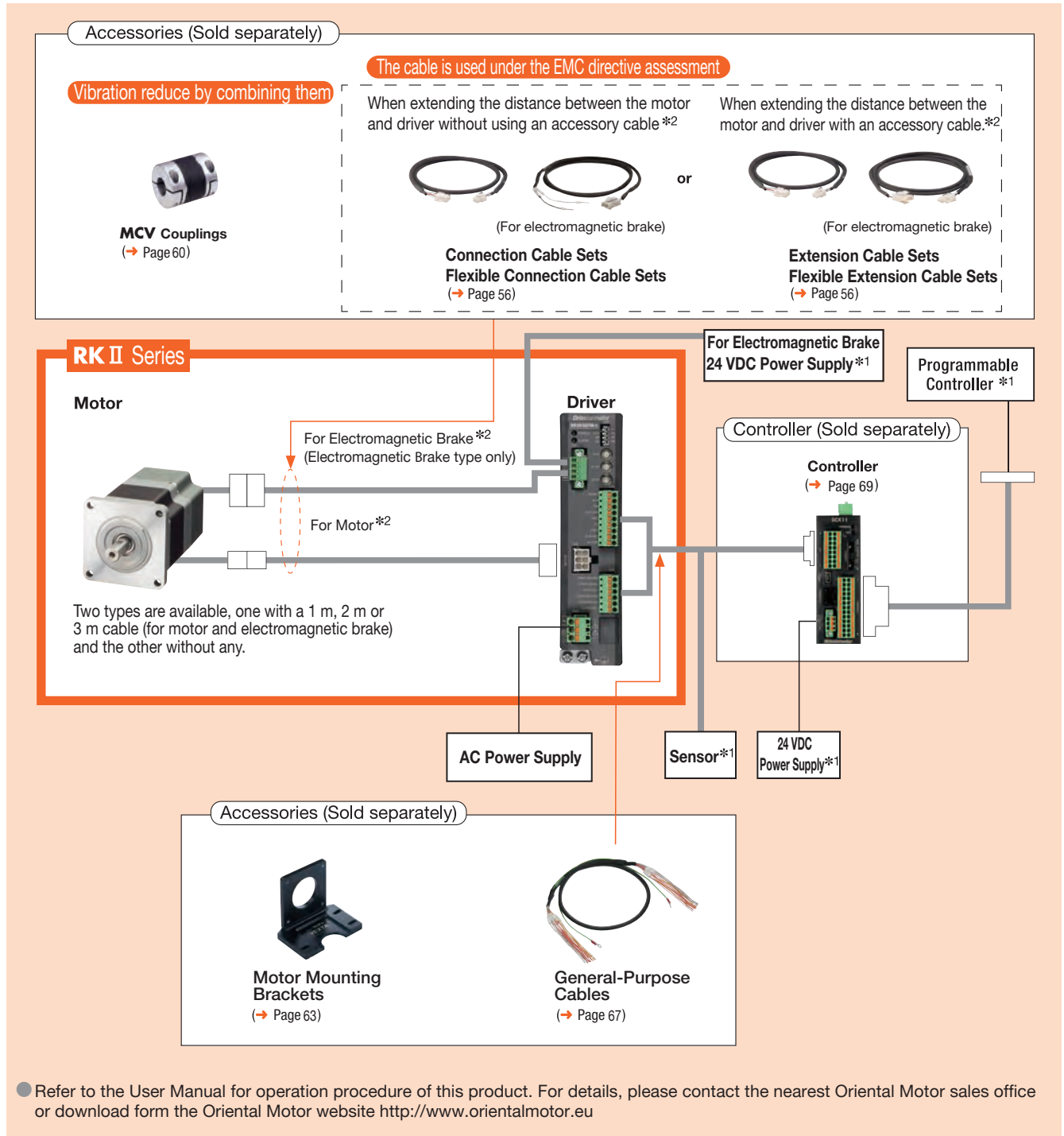

System Configuration Example

RKII Series RKS566MC-3	+	Sold Separately			
		Controller SCX11	Motor Mounting Bracket PAL2P-5	Flexible Coupling MCV251010	General-Purpose Cable (1 m) CC16D010B-1

● The system configuration shown above is an example. Other combinations are available.

Product Number Code

RKS 5 6 4 R C D 2 - 3

① ② ③ ④ ⑤ ⑥ ⑦ ⑧ ⑪

RKS 5 6 4 M C D - HS 50 - 3

① ② ③ ④ ⑤ ⑥ ⑦ ⑨ ⑩ ⑪

①	Series Name	RKS : RKII series
②	5 : 5-Phase	
③	Motor Frame Size	4 : 42 mm 6 : 60 mm 9 : 85 mm (Motor Frame Size for Geared Type 90 mm)
④	Motor Case Length	
⑤	Motor Type	A : Single shaft B : Double shaft R : Encoder Type M : Electromagnetic Brake Type
⑥	Power Supply Voltage	A : Single-Phase 100-120 VAC C : Single-Phase 200-240 VAC
⑦	Driver Type	D : Built-In Controller Type Blank : Pulse Input Type
⑧	Serial Number	
⑨	Gearhead Type	Blank : Standard Type TS : TS Geared Type PS : PS Geared Type HS : Harmonic Geared Type
⑩	Gear Ratio	
⑪	Connecting Cable	Numeric value : Cable length (included in package) 1 : 1 m 2 : 2 m 3 : 3 m Blank : Package without cable

Product Line

Built-In Controller Type

Standard Type

Product Name (Single Shaft)	Product Name (Double Shaft)
RKS543A <input type="checkbox"/> D-◇	RKS543B <input type="checkbox"/> D-◇
RKS544A <input type="checkbox"/> D-◇	RKS544B <input type="checkbox"/> D-◇
RKS545A <input type="checkbox"/> D-◇	RKS545B <input type="checkbox"/> D-◇
RKS564A <input type="checkbox"/> D-◇	RKS564B <input type="checkbox"/> D-◇
RKS566A <input type="checkbox"/> D-◇	RKS566B <input type="checkbox"/> D-◇ RKS-569B <input type="checkbox"/> D-◇
RKS569A <input type="checkbox"/> D-◇	
RKS596A <input type="checkbox"/> D-◇	RKS596B <input type="checkbox"/> D-◇
RKS599A <input type="checkbox"/> D-◇	RKS599B <input type="checkbox"/> D-◇ RKS-5913B <input type="checkbox"/> D-◇
RKS5913A <input type="checkbox"/> D-◇	

Standard Type with Electromagnetic Brake

Product Name
RKS543M <input type="checkbox"/> D-◇
RKS544M <input type="checkbox"/> D-◇
RKS545M <input type="checkbox"/> D-◇
RKS564M <input type="checkbox"/> D-◇
RKS566M <input type="checkbox"/> D-◇
RKS569M <input type="checkbox"/> D-◇
RKS596M <input type="checkbox"/> D-◇
RKS599M <input type="checkbox"/> D-◇
RKS5913M <input type="checkbox"/> D-◇

Standard Type with Encoder

Product Name
RKS543R <input type="checkbox"/> D2-◇
RKS544R <input type="checkbox"/> D2-◇
RKS545R <input type="checkbox"/> D2-◇
RKS564R <input type="checkbox"/> D2-◇
RKS566R <input type="checkbox"/> D2-◇
RKS569R <input type="checkbox"/> D2-◇
RKS596R <input type="checkbox"/> D2-◇
RKS599R <input type="checkbox"/> D2-◇
RKS5913R <input type="checkbox"/> D2-◇

TS Geared Type

Product Name (Single Shaft)	Product Name (Double Shaft)
RKS543A <input type="checkbox"/> D-TS3.6-◇	RKS543B <input type="checkbox"/> D-TS3.6-◇
RKS543A <input type="checkbox"/> D-TS7.2-◇	RKS543B <input type="checkbox"/> D-TS7.2-◇
RKS543A <input type="checkbox"/> D-TS10-◇	RKS543B <input type="checkbox"/> D-TS10-◇
RKS543A <input type="checkbox"/> D-TS20-◇	RKS543B <input type="checkbox"/> D-TS20-◇
RKS543A <input type="checkbox"/> D-TS30-◇	RKS543B <input type="checkbox"/> D-TS30-◇
RKS564A <input type="checkbox"/> D-TS3.6-◇	RKS564B <input type="checkbox"/> D-TS3.6-◇
RKS564A <input type="checkbox"/> D-TS7.2-◇	RKS564B <input type="checkbox"/> D-TS7.2-◇
RKS564A <input type="checkbox"/> D-TS10-◇	RKS564B <input type="checkbox"/> D-TS10-◇
RKS564A <input type="checkbox"/> D-TS20-◇	RKS564B <input type="checkbox"/> D-TS20-◇
RKS564A <input type="checkbox"/> D-TS30-◇	RKS564B <input type="checkbox"/> D-TS30-◇
RKS596A <input type="checkbox"/> D-TS3.6-◇	RKS596B <input type="checkbox"/> D-TS3.6-◇
RKS596A <input type="checkbox"/> D-TS7.2-◇	RKS596B <input type="checkbox"/> D-TS7.2-◇
RKS596A <input type="checkbox"/> D-TS10-◇	RKS596B <input type="checkbox"/> D-TS10-◇
RKS596A <input type="checkbox"/> D-TS20-◇	RKS596B <input type="checkbox"/> D-TS20-◇
RKS596A <input type="checkbox"/> D-TS30-◇	RKS596B <input type="checkbox"/> D-TS30-◇

TS Geared Type with Electromagnetic Brake

Product Name (Single Shaft)
RKS543M <input type="checkbox"/> D-TS3.6-◇
RKS543M <input type="checkbox"/> D-TS7.2-◇
RKS543M <input type="checkbox"/> D-TS10-◇
RKS543M <input type="checkbox"/> D-TS20-◇
RKS543M <input type="checkbox"/> D-TS30-◇
RKS564M <input type="checkbox"/> D-TS3.6-◇
RKS564M <input type="checkbox"/> D-TS7.2-◇
RKS564M <input type="checkbox"/> D-TS10-◇
RKS564M <input type="checkbox"/> D-TS20-◇
RKS564M <input type="checkbox"/> D-TS30-◇
RKS596M <input type="checkbox"/> D-TS3.6-◇
RKS596M <input type="checkbox"/> D-TS7.2-◇
RKS596M <input type="checkbox"/> D-TS10-◇
RKS596M <input type="checkbox"/> D-TS20-◇
RKS596M <input type="checkbox"/> D-TS30-◇

● Either **A** (single-phase 100-120 VAC) or **C** (single-phase 200-240 VAC) indicating the power supply input is entered where the box is located within the product name.
A number indicating the desired length of **1** (1 m), **2** (2 m) or **3** (3 m) for the cable included with the product is entered where the box is located within the product name.
● Oriental Motor Corp. provide user's manual for this product. For more detail, please contact to our branch, sales office or the user can download it from our website.
<http://www.orientalmotor.eu>

Note

● The cable on the Electromagnetic Brake or Encoder cannot be connected to the driver directly. To connect to the driver, please purchase connection cable separately or choose the package come with the connection cable (The package includes a connection cable).

◇ **PS Geared Type**

Product Name (Single Shaft)
RKS545A □ D-PS5-◇
RKS545A □ D-PS7.2-◇
RKS545A □ D-PS10-◇
RKS543A □ D-PS25-◇
RKS543A □ D-PS36-◇
RKS543A □ D-PS50-◇
RKS566A □ D-PS5-◇
RKS566A □ D-PS7.2-◇
RKS566A □ D-PS10-◇
RKS564A □ D-PS25-◇
RKS564A □ D-PS36-◇
RKS564A □ D-PS50-◇
RKS599A □ D-PS5-◇
RKS599A □ D-PS7.2-◇
RKS599A □ D-PS10-◇
RKS596A □ D-PS25-◇
RKS596A □ D-PS36-◇
RKS596A □ D-PS50-◇

Product Name (Double Shaft)
RKS545B □ D-PS5-◇
RKS545B □ D-PS7.2-◇
RKS545B □ D-PS10-◇
RKS543B □ D-PS25-◇
RKS543B □ D-PS36-◇
RKS543B □ D-PS50-◇
RKS566B □ D-PS5-◇
RKS566B □ D-PS7.2-◇
RKS566B □ D-PS10-◇
RKS564B □ D-PS25-◇
RKS564B □ D-PS36-◇
RKS564B □ D-PS50-◇
RKS599B □ D-PS5-◇
RKS599B □ D-PS7.2-◇
RKS599B □ D-PS10-◇
RKS596B □ D-PS25-◇
RKS596B □ D-PS36-◇
RKS596B □ D-PS50-◇

◇ **PS Geared Type with Electromagnetic Brake**

Product Name (Single Shaft)
RKS545M □ D-PS5-◇
RKS545M □ D-PS7.2-◇
RKS545M □ D-PS10-◇
RKS543M □ D-PS25-◇
RKS543M □ D-PS36-◇
RKS543M □ D-PS50-◇
RKS566M □ D-PS5-◇
RKS566M □ D-PS7.2-◇
RKS566M □ D-PS10-◇
RKS564M □ D-PS25-◇
RKS564M □ D-PS36-◇
RKS564M □ D-PS50-◇
RKS599M □ D-PS5-◇
RKS599M □ D-PS7.2-◇
RKS599M □ D-PS10-◇
RKS596M □ D-PS25-◇
RKS596M □ D-PS36-◇
RKS596M □ D-PS50-◇

◇ **Harmonic Geared Type**

Product Name (Single Shaft)
RKS543A □ D-HS50-◇
RKS543A □ D-HS100-◇
RKS564A □ D-HS50-◇
RKS564A □ D-HS100-◇
RKS596A □ D-HS50-◇
RKS596A □ D-HS100-◇

Product Name (Double Shaft)
RKS543B □ D-HS50-◇
RKS543B □ D-HS100-◇
RKS564B □ D-HS50-◇
RKS564B □ D-HS100-◇
RKS596B □ D-HS50-◇
RKS596B □ D-HS100-◇

◇ **Harmonic Geared Type with Electromagnetic Brake**

Product Name
RKS543M □ D-HS50-◇
RKS543M □ D-HS100-◇
RKS564M □ D-HS50-◇
RKS564M □ D-HS100-◇
RKS596M □ D-HS50-◇
RKS596M □ D-HS100-◇

● **Pulse Input Type**

◇ **Standard Type**

Product Name (Single Shaft)
RKS543A □ -◇
RKS544A □ -◇
RKS545A □ -◇
RKS564A □ -◇
RKS566A □ -◇
RKS569A □ -◇
RKS596A □ -◇
RKS599A □ -◇
RKS5913A □ -◇

Product Name (Double Shaft)
RKS543B □ -◇
RKS544B □ -◇
RKS545B □ -◇
RKS564B □ -◇
RKS566B □ -◇
RKS569B □ -◇
RKS596B □ -◇
RKS599B □ -◇
RKS5913B □ -◇

◇ **Standard Type with Electromagnetic Brake**

Product Name
RKS543M □ -◇
RKS544M □ -◇
RKS545M □ -◇
RKS564M □ -◇
RKS566M □ -◇
RKS569M □ -◇
RKS596M □ -◇
RKS599M □ -◇
RKS5913M □ -◇

- Either **A** (single-phase 100-120 VAC) or **C** (single-phase 200-240 VAC) indicating the power supply input is entered where the box □ is located within the product name. A number indicating the desired length of **1** (1 m), **2** (2 m) or **3** (3 m) for the cable included with the product is entered where the box ◇ is located within the product name.
- Oriental Motor Corp. provide user's manual for this product. For more detail, please contact to our branch, sales office or the user can download it from our website. <http://www.orientalmotor.eu>

Note

- The cable on the Electromagnetic Brake or Encoder cannot be connected to the driver directly. To connect to the driver, please purchase connection cable separately or choose the package come with the connection cable (The package includes a connection cable).

◇ TS Geared Type

Product Name (Single Shaft)
RKS543A- TS3.6 -◇
RKS543A- TS7.2 -◇
RKS543A- TS10 -◇
RKS543A- TS20 -◇
RKS543A- TS30 -◇
RKS564A- TS3.6 -◇
RKS564A- TS7.2 -◇
RKS564A- TS10 -◇
RKS564A- TS20 -◇
RKS564A- TS30 -◇
RKS596A- TS3.6 -◇
RKS596A- TS7.2 -◇
RKS596A- TS10 -◇
RKS596A- TS20 -◇
RKS596A- TS30 -◇

◇ TS Geared Type with Electromagnetic Brake

Product Name (Single Shaft)
RKS543M- TS3.6 -◇
RKS543M- TS7.2 -◇
RKS543M- TS10 -◇
RKS543M- TS20 -◇
RKS543M- TS30 -◇
RKS564M- TS3.6 -◇
RKS564M- TS7.2 -◇
RKS564M- TS10 -◇
RKS564M- TS20 -◇
RKS564M- TS30 -◇
RKS596M- TS3.6 -◇
RKS596M- TS7.2 -◇
RKS596M- TS10 -◇
RKS596M- TS20 -◇
RKS596M- TS30 -◇

◇ PS Geared Type

Product Name (Single Shaft)
RKS545A- PS5 -◇
RKS545A- PS7.2 -◇
RKS545A- PS10 -◇
RKS543A- PS25 -◇
RKS543A- PS36 -◇
RKS543A- PS50 -◇
RKS566A- PS5 -◇
RKS566A- PS7.2 -◇
RKS566A- PS10 -◇
RKS564A- PS25 -◇
RKS564A- PS36 -◇
RKS564A- PS50 -◇
RKS599A- PS5 -◇
RKS599A- PS7.2 -◇
RKS599A- PS10 -◇
RKS596A- PS25 -◇
RKS596A- PS36 -◇
RKS596A- PS50 -◇

◇ PS Geared Type with Electromagnetic Brake

Product Name (Double Shaft)
RKS545B- PS5 -◇
RKS545B- PS7.2 -◇
RKS545B- PS10 -◇
RKS543B- PS25 -◇
RKS543B- PS36 -◇
RKS543B- PS50 -◇
RKS566B- PS5 -◇
RKS566B- PS7.2 -◇
RKS566B- PS10 -◇
RKS564B- PS25 -◇
RKS564B- PS36 -◇
RKS564B- PS50 -◇
RKS599B- PS5 -◇
RKS599B- PS7.2 -◇
RKS599B- PS10 -◇
RKS596B- PS25 -◇
RKS596B- PS36 -◇
RKS596B- PS50 -◇

◇ PS Geared Type with Electromagnetic Brake

Product Name (Single Shaft)
RKS545M- PS5 -◇
RKS545M- PS7.2 -◇
RKS545M- PS10 -◇
RKS543M- PS25 -◇
RKS543M- PS36 -◇
RKS543M- PS50 -◇
RKS566M- PS5 -◇
RKS566M- PS7.2 -◇
RKS566M- PS10 -◇
RKS564M- PS25 -◇
RKS564M- PS36 -◇
RKS564M- PS50 -◇
RKS599M- PS5 -◇
RKS599M- PS7.2 -◇
RKS599M- PS10 -◇
RKS596M- PS25 -◇
RKS596M- PS36 -◇
RKS596M- PS50 -◇

◇ Harmonic Geared Type

Product Name (Single Shaft)
RKS543A- HS50 -◇
RKS543A- HS100 -◇
RKS564A- HS50 -◇
RKS564A- HS100 -◇
RKS596A- HS50 -◇
RKS596A- HS100 -◇

◇ Harmonic Geared Type with Electromagnetic Brake

Product Name (Double Shaft)
RKS543B- HS50 -◇
RKS543B- HS100 -◇
RKS564B- HS50 -◇
RKS564B- HS100 -◇
RKS596B- HS50 -◇
RKS596B- HS100 -◇

◇ Harmonic Geared Type with Electromagnetic Brake

Product Name
RKS543M- HS50 -◇
RKS543M- HS100 -◇
RKS564M- HS50 -◇
RKS564M- HS100 -◇
RKS596M- HS50 -◇
RKS596M- HS100 -◇

- Either **A** (single-phase 100-120 VAC) or **C** (single-phase 200-240 VAC) indicating the power supply input is entered where the box **■** is located within the product name.
A number indicating the desired length of **1** (1 m), **2** (2 m) or **3** (3 m) for the cable included with the product is entered where the box **◇** is located within the product name.
- Oriental Motor Corp. provide user's manual for this product. For more detail, please contact to our branch, sales office or the user can download it from our website.
<http://www.orientalmotor.eu>

Note

- The cable on the Electromagnetic Brake or Encoder cannot be connected to the driver directly. To connect to the driver, please purchase connection cable separately or choose the package come with the connection cable (The package includes a connection cable).

Standard Type Frame Size 42 mm, 60 mm

Standard Type with Electromagnetic Brake Frame Size 42 mm, 60 mm

Standard Type with Encoder Frame Size 42 mm, 60 mm

Specifications RoHS



Product Name	Built-in Controller Type		RKS543	RKS544	RKS545	RKS564	RKS566	RKS569
	Pulse Input Type		RKS543	RKS544	RKS545	RKS564	RKS566	RKS569
Maximum Holding Torque	N·m		0.14	0.21	0.27	0.52	0.96	1.77
Holding Torque at Motor Standstill	Power ON	N·m	0.07	0.10	0.13	0.26	0.48	0.88
	Electromagnetic Brake	N·m	0.07	0.10	0.13	0.26	0.48	0.88
Rotor Inertia	J : kg·m ²		30×10 ⁻⁷ [45×10 ⁻⁷]*1 (31×10 ⁻⁷)*2	47×10 ⁻⁷ [62×10 ⁻⁷]*1 (48×10 ⁻⁷)*2	64×10 ⁻⁷ [79×10 ⁻⁷]*1 (65×10 ⁻⁷)*2	160×10 ⁻⁷ [320×10 ⁻⁷]*1 (160×10 ⁻⁷)*2	270×10 ⁻⁷ [430×10 ⁻⁷]*1 (270×10 ⁻⁷)*2	540×10 ⁻⁷ [700×10 ⁻⁷]*1 (540×10 ⁻⁷)*2
Rated Current	A / Phase		0.35			0.75		
Basic Step Angle			0.72°					
Power Supply Input	Voltage / Frequency		Single-Phase 100-120 VAC, Single-Phase 200-240 VAC -15~+10% 50/60 Hz					
	Input Current	Single-Phase 100-120 VAC	2.1	1.9	1.9	4.0	3.8	4.0
	A	Single-Phase 200-240 VAC	1.3	1.2	1.2	2.4	2.4	2.5
Excitation Mode			Microstep					
Control Power Supply*3			24 VDC±5% 0.2 A					
Electromagnetic Brake*4	Power Supply Input		24 VDC±5%*5 0.08 A			24 VDC±5%*5 0.25 A		

Definition → Refer to page 22

● For Built-in Controller package, either **A** (single shaft), **B** (double shaft), **M** (electromagnetic brake) or **R** (encoder) indicating the configuration is entered where the box is located within the product name.

For Pulse Input package, either **A** (single shaft), **B** (double shaft) or **M** (electromagnetic brake) indicating the configuration is entered where the box is located within the product name.

Either **A** (Single-Phase 100-120 VAC) or **C** (Single-Phase 200-240 VAC) indicating the configuration is entered where is located within the product name.

For encoder type, **2** will be entered where is located within the product name.

A number indicating the desired length of **1** (1 m), **2** (2 m) or **3** (3 m) for the cable included with the product is entered where the box is located within the product name.

*1 The values inside the brackets [] represent the specification for the electromagnetic brake type.

*2 The values inside the brackets () represent the specification for the encoder type.

*3 For Built-in Controller package, the control power supply is required.

*4 For pulse input package, a separate power supply for electromagnetic brakes is required.

*5 If the wiring distance between the motor and driver is extended to 15 m or longer by using an accessory cable (sold separately), the 24 VDC±4% specification applies.

Speed -Torque Characteristics fs: Maximum Starting Frequency

RKS543

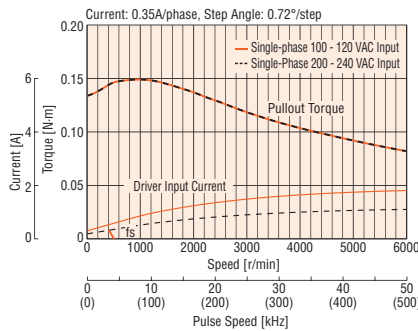

RKS544

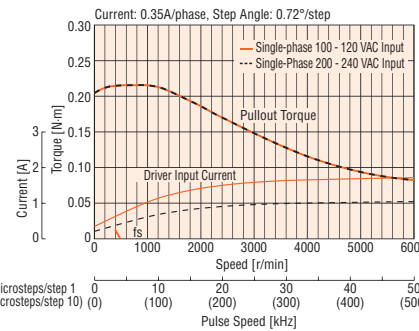

RKS545

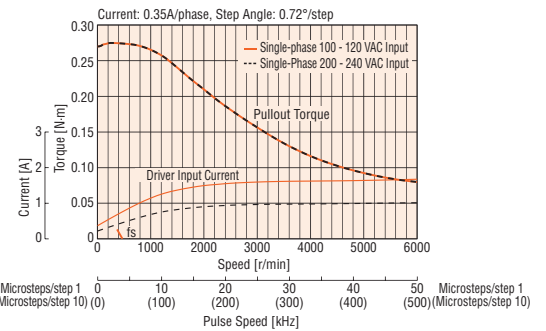

RKS564

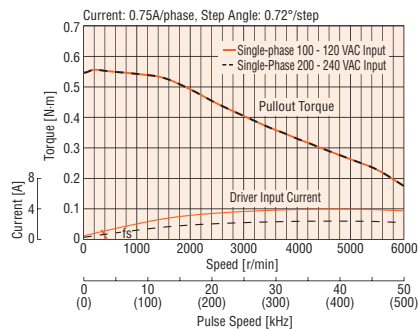

RKS566

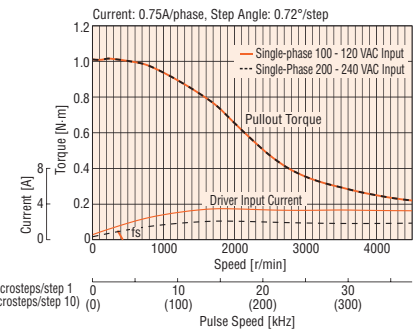

RKS569

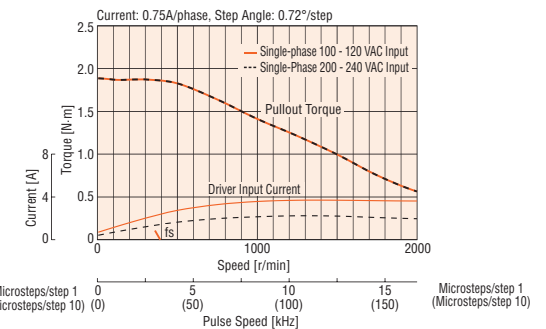

Note

● Pay attention to heat dissipation from the motor as there will be a considerable amount of heat under certain conditions. Be sure to keep the temperature of the motor case under 100°C.

For the Encoder type, in order to protect encoder, be sure to keep the temperature of the motor case under 85°C.

Standard Type Frame Size 85 mm

Standard Type with Electromagnetic Brake Frame Size 85 mm

Standard Type with Encoder Frame Size 85 mm

Specifications (RoHS)



Product Name	Built-In Controller Type		RKS596	RKS599	RKS5913
	Pulse Input Type		RKS596	RKS599	RKS5913
Maximum Holding Torque	N-m		2.1	4.1	6.3
Holding Torque at Motor Standstill	Power ON	N-m	1.05	2.05	3.15
	Electromagnetic Brake	N-m	1.05	2.05	3.15
Rotor Inertia	J : kg·m ²		1100×10 ⁻⁷ [2200×10 ⁻⁷]*1 (1100×10 ⁻⁷)*2	2200×10 ⁻⁷ [3300×10 ⁻⁷]*1 (2200×10 ⁻⁷)*2	3300×10 ⁻⁷ [4400×10 ⁻⁷]*1 (3300×10 ⁻⁷)*2
	A / Phase		0.75		
Basic Step Angle		0.72°			
Voltage / Frequency		Single-Phase 100-120 VAC, Single-Phase 200-240 VAC -15~+10% 50/60 Hz			
Power Supply Input	Input Current	Single-Phase 100-120 VAC	3.6	3.5	3.5
	A	Single-Phase 200-240 VAC	2.1	2.2	2.2
Excitation Mode		Microstep			
Control Power Supply*3		24 VDC±5% 0.2 A			
Electromagnetic Brake*4		Power Supply Input 24 VDC±5%*5 0.42 A			

Definition → Refer to the list in following box.

● For Built-in Controller package, either **A** (single shaft), **B** (double shaft), **M** (electromagnetic brake) or **R** (encoder) indicating the configuration is entered where the box is located within the product name.

For Pulse Input package, either **A** (single shaft), **B** (double shaft) or **M** (electromagnetic brake) indicating the configuration is entered where the box is located within the product name.

Either **A** (Single-Phase 100-120 VAC) or **C** (Single-Phase 200-240 VAC) indicating the configuration is entered where is located within the product name.

For encoder type, **2** will be entered where is located within the product name.

A number indicating the desired length of **1** (1 m), **2** (2 m) or **3** (3 m) for the cable included with the product is entered where the box is located within the product name.

*1 The values inside the brackets [] represent the specification for the electromagnetic brake type.

*2 The values inside the brackets () represent the specification for the encoder type.

*3 For Built-in Controller package, the control power supply is required.

*4 For pulse input package, a separate power supply for electromagnetic brakes is required.

*5 If the wiring distance between the motor and driver is extended to 15 m or longer by using an accessory cable (sold separately), the 24 VDC±4% specification applies.

Speed -Torque Characteristics fs: Maximum Starting Frequency

RKS596

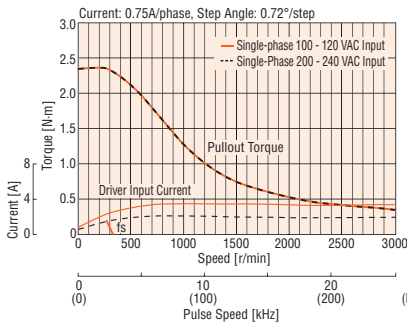

RKS599

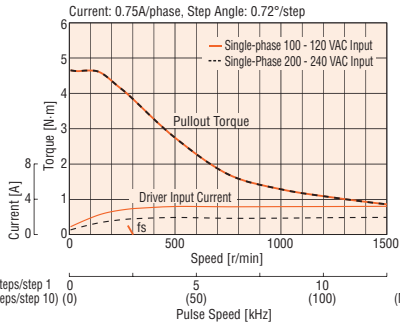

RKS5913

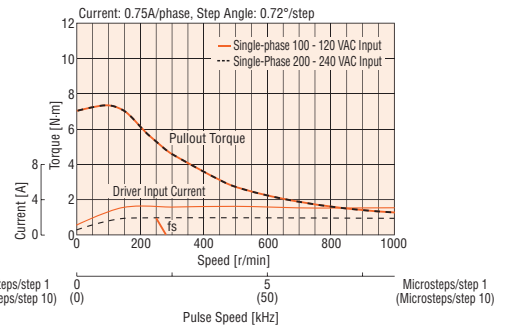

Note

● Pay attention to heat dissipation from the motor as there will be a considerable amount of heat under certain conditions. Be sure to keep the temperature of the motor case under 100°C.

For the Encoder type, in order to protect encoder, be sure to keep the temperature of the motor case under 85°C.

[When conforming to the UL or CSA Standards, it is required to keep the temperature of the motor case at 75°C or less, since the motor is recognized as Thermal class 105 (A).]

Definition

Maximum Holding Torque	: Maximum Holding Torque (holding power) while motor standstill (power supplied at the Rated Current).
Permissible Torque	: Maximum Torque load applied to Gear Output Shaft
Maximum Torque	: Maximum Torque load applied to Gear Output Shaft when up/reduce the speed (i.e.. start-up or shut-down of Load Inertia).
Holding Torque at Motor Standstill	Power ON : Holding Torque under Automatic Current Cutback function is operated.
	Electromagnetic Brake : Static friction torque generated by Electromagnetic Brake at motor standstill. (Power Off Activated Type Electromagnetic Brake)

TS Geared Type Frame Size 42 mm

TS Geared Type with Electromagnetic Brake Frame Size 42 mm

Specifications RoHS



Product Name	Built-In Controller Type		RKS543 D-TS3.6 ◇	RKS543 D-TS7.2 ◇	RKS543 D-TS10 ◇	RKS543 D-TS20 ◇	RKS543 D-TS30 ◇
	Pulse Input Type		RKS543 TS3.6 ◇	RKS543 TS7.2 ◇	RKS543 TS10 ◇	RKS543 TS20 ◇	RKS543 TS30 ◇
Maximum Holding Torque	N·m	0.5	1	1.4	2	2.3	
Rotor Inertia	J : kg·m ²	30×10^{-7} [45×10^{-7}]*1					
Rated Current	A / Phase	0.35					
Basic Step Angle		0.2°	0.1°	0.072°	0.036°	0.024°	
Gear Ratio		3.6	7.2	10	20	30	
Permissible Torque*2	N·m	0.65	1.2	1.7	2	2.3	
Maximum Torque*2	N·m	0.85	1.6	2	3	3	
Holding Torque at Power ON	N·m	0.26	0.53	0.74	1.48	2.2	
Motor Standstill Electromagnetic Brake	N·m	0.26	0.53	0.74	1.48	2.2	
Permissible Speed Range	r/min	0~833	0~416	0~300	0~150	0~100	
Backlash	arc min	45(0.75°)	25(0.42°)			15(0.25°)	
Power Supply Input	Voltage / Frequency		Single-Phase 100-120 VAC, Single-Phase 200-240 VAC -15~+10% 50/60 Hz				
	Input Current A	Single-Phase 100-120 VAC Single-Phase 200-240 VAC	2.1 1.3				
Excitation Mode		Microstep					
Control Power Supply*3		24 VDC±5% 0.2 A					
Electromagnetic Brake*4	Power Supply Input	24 VDC±5%*5 0.08 A					

Definition → Refer to page 22

● Either **A** (single shaft), **B** (double shaft) or **M** (electromagnetic brake) indicating the configuration is entered where the box is located within the product name.

Either **A** (Single-Phase 100-120 VAC) or **C** (Single-Phase 200-240 VAC) indicating the configuration is entered where is located within the product name.

A number indicating the desired length of **1** (1 m), **2** (2 m) or **3** (3 m) for the cable included with the product is entered where the box ◇ is located within the product name.

*1 The values inside the brackets [] represent the specification for the electromagnetic brake type.

*2 Permissible Torque and Maximum Torque shown above is value recorded at the Gear. Refer to Speed -Torque Specification graph for output torque of Geared Motor.

*3 For Built-in Controller package, the control power supply is required.

*4 For pulse input package, a separate power supply for electromagnetic brakes is required.

*5 If the wiring distance between the motor and driver is extended to 15 m or longer by using an accessory cable (sold separately), the 24 VDC±4% specification applies.

Speed -Torque Characteristics fs: Maximum Starting Frequency

RKS543 Gear Ratio: 3.6

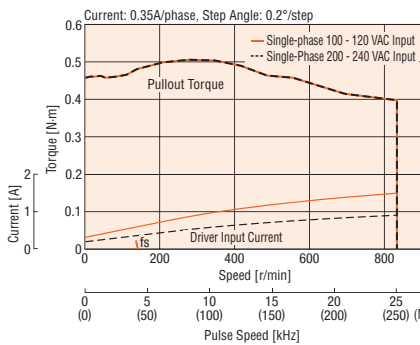

RKS543 Gear Ratio: 7.2

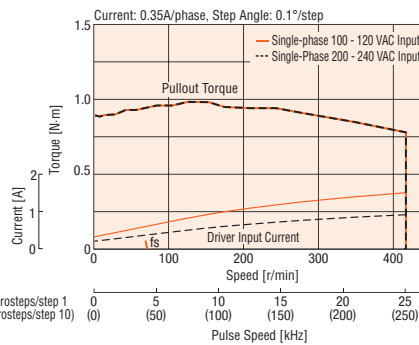

RKS543 Gear Ratio: 10

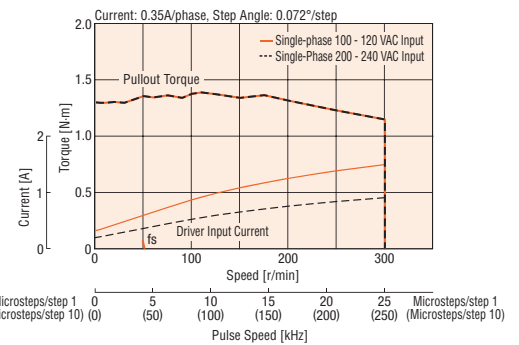

RKS543 Gear Ratio: 20

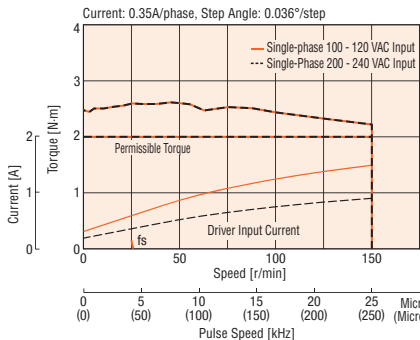

RKS543 Gear Ratio: 30

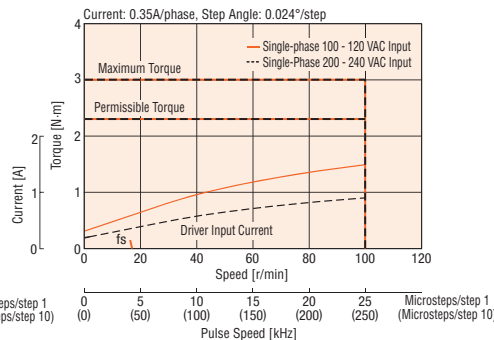

Note

● Pay attention to heat dissipation from the motor as there will be a considerable amount of heat under certain conditions. Be sure to keep the temperature of the motor case under 100°C.

[When conforming to the UL or CSA Standards, it is required to keep the temperature of the motor case at 75°C or less, since the motor is recognized as Thermal class 105 (A).]

TS Geared Type Frame Size 60 mm

TS Geared Type with Electromagnetic Brake Frame Size 60 mm

Specifications (RoHS)



Product Name		Built-In Controller Type	RKS564 <input type="checkbox"/> D-TS3.6- <input type="checkbox"/>	RKS564 <input type="checkbox"/> D-TS7.2- <input type="checkbox"/>	RKS564 <input type="checkbox"/> D-TS10- <input type="checkbox"/>	RKS564 <input type="checkbox"/> D-TS20- <input type="checkbox"/>	RKS564 <input type="checkbox"/> D-TS30- <input type="checkbox"/>
Pulse Input Type			RKS564 <input type="checkbox"/> TS3.6- <input type="checkbox"/>	RKS564 <input type="checkbox"/> TS7.2- <input type="checkbox"/>	RKS564 <input type="checkbox"/> TS10- <input type="checkbox"/>	RKS564 <input type="checkbox"/> TS20- <input type="checkbox"/>	RKS564 <input type="checkbox"/> TS30- <input type="checkbox"/>
Maximum Holding Torque	N·m		1.8	3	4	5	6
Rotor Inertia	J : kg·m ²		160×10 ⁻⁷ [320×10 ⁻⁷]*1				
Rated Current	A / Phase		0.75				
Basic Step Angle			0.2°	0.1°	0.072°	0.036°	0.024°
Gear Ratio			3.6	7.2	10	20	30
Permissible Torque*2	N·m		1.8	3	4	5	6
Maximum Torque*2	N·m		2.5	4.5	6	8	10
Holding Torque at Power ON	N·m		1	2	2.9	5	6
Motor Standstill Electromagnetic Brake	N·m		1	2	2.9	5	6
Permissible Speed Range	r/min		0~833	0~416	0~300	0~150	0~100
Backlash	arc min		35(0.59°)	15(0.25°)		10(0.17°)	
Power Supply Input	Voltage / Frequency		Single-Phase 100-120 VAC, Single-Phase 200-240 VAC -15~+10% 50/60 Hz				
	Input	Single-Phase 100-120 VAC	4.0				
	Current A	Single-Phase 200-240 VAC	2.4				
Excitation Mode			Microstep				
Control Power Supply*3			24 VDC±5% 0.2 A				
Electromagnetic Brake*4	Power Supply Input		24 VDC±5%*5 0.25 A				

Definition → Refer to page 22

● Either **A** (single shaft), **B** (double shaft) or **M** (electromagnetic brake) indicating the configuration is entered where the box is located within the product name.

Either **A** (Single-Phase 100-120 VAC) or **C** (Single-Phase 200-240 VAC) indicating the configuration is entered where is located within the product name.

A number indicating the desired length of **1** (1 m), **2** (2 m) or **3** (3 m) for the cable included with the product is entered where the box is located within the product name.

*1 The values inside the brackets [] represent the specification for the electromagnetic brake type.

*2 Permissible Torque and Maximum Torque shown above is value recorded at the Gear. Refer to Speed -Torque Specification graph for output torque of Geared Motor.

*3 For Built-in Controller package, the control power supply is required.

*4 For pulse input package, a separate power supply for electromagnetic brakes is required.

*5 If the wiring distance between the motor and driver is extended to 15 m or longer by using an accessory cable (sold separately), the 24 VDC±4% specification applies.

Speed -Torque Characteristics *fs*: Maximum Starting Frequency

RKS564 Gear Ratio: 3.6

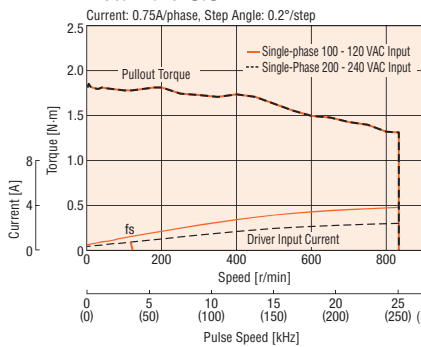

RKS564 Gear Ratio: 7.2

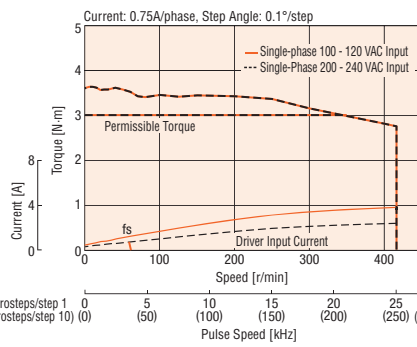

RKS564 Gear Ratio: 10

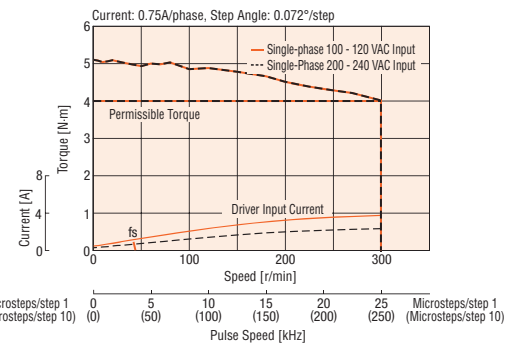

RKS564 Gear Ratio: 20

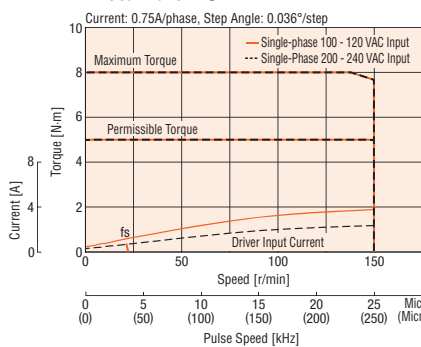

RKS564 Gear Ratio: 30

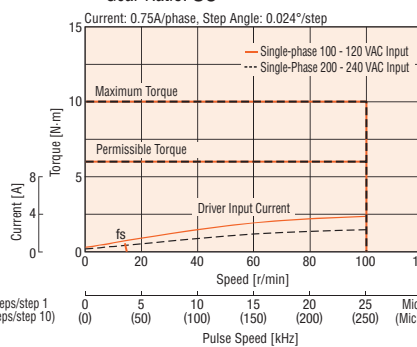

Note

● Pay attention to heat dissipation from the motor as there will be a considerable amount of heat under certain conditions. Be sure to keep the temperature of the motor case under 100°C.

[When conforming to the UL or CSA Standards, it is required to keep the temperature of the motor case at 75°C or less, since the motor is recognized as Thermal class 105 (A).]

TS Geared Type Frame Size 90 mm

TS Geared Type with Electromagnetic Brake Frame Size 90 mm

Specifications (RoHS)



Product Name	Built-In Controller Type		RKS596 <input type="checkbox"/> D-TS3.6- <input type="checkbox"/>	RKS596 <input type="checkbox"/> D-TS7.2- <input type="checkbox"/>	RKS596 <input type="checkbox"/> D-TS10- <input type="checkbox"/>	RKS596 <input type="checkbox"/> D-TS20- <input type="checkbox"/>	RKS596 <input type="checkbox"/> D-TS30- <input type="checkbox"/>
	Pulse Input Type		RKS596 <input type="checkbox"/> TS3.6- <input type="checkbox"/>	RKS596 <input type="checkbox"/> TS7.2- <input type="checkbox"/>	RKS596 <input type="checkbox"/> TS10- <input type="checkbox"/>	RKS596 <input type="checkbox"/> TS20- <input type="checkbox"/>	RKS596 <input type="checkbox"/> TS30- <input type="checkbox"/>
Maximum Holding Torque	N·m		6	10	14	20	25
Rotor Inertia	J : kg·m ²		1100×10 ⁻⁷ [2200×10 ⁻⁷]*1				
Rated Current	A / Phase		0.75				
Basic Step Angle			0.2°	0.1°	0.072°	0.036°	0.024°
Gear Ratio			3.6	7.2	10	20	30
Permissible Torque*2	N·m		6	10	14	20	25
Maximum Torque*2	N·m		9	15	20	35	45
Holding Torque at Power ON	N·m		4.5	9	7.4	14.8	22
Motor Standstill	Electromagnetic Brake		4.5	9	7.4	14.8	22
Permissible Speed Range	r/min		0~833	0~416	0~300	0~150	0~100
Backlash	arc min		25(0.42°)	15(0.25°)		10(0.17°)	
Power Supply Input	Voltage / Frequency		Single-Phase 100-120 VAC, Single-Phase 200-240 VAC -15~+10% 50/60 Hz				
	Input	Single-Phase 100-120 VAC	3.6			4.9	
	Current A	Single-Phase 200-240 VAC	2.1			3.0	
Excitation Mode			Microstep				
Control Power Supply*3			24 VDC±5% 0.2 A				
Electromagnetic Brake*4	Power Supply Input		24 VDC±5%*5 0.42 A				

Definition → Refer to page 22

● Either **A** (single shaft), **B** (double shaft) or **M** (electromagnetic brake) indicating the configuration is entered where the box is located within the product name.

Either **A** (Single-Phase 100-120 VAC) or **C** (Single-Phase 200-240 VAC) indicating the configuration is entered where is located within the product name.

A number indicating the desired length of **1** (1 m), **2** (2 m) or **3** (3 m) for the cable included with the product is entered where the box is located within the product name.

*1 The values inside the brackets [] represent the specification for the electromagnetic brake type.

*2 Permissible Torque and Maximum Torque shown above is value recorded at the Gear. Refer to Speed -Torque Specification graph for output torque of Geared Motor.

*3 For Built-in Controller package, the control power supply is required.

*4 For pulse input package, a separate power supply for electromagnetic brakes is required.

*5 If the wiring distance between the motor and driver is extended to 15 m or longer by using an accessory cable (sold separately), the 24 VDC±4% specification applies.

Speed -Torque Characteristics fs: Maximum Starting Frequency

RKS596 Gear Ratio: 3.6

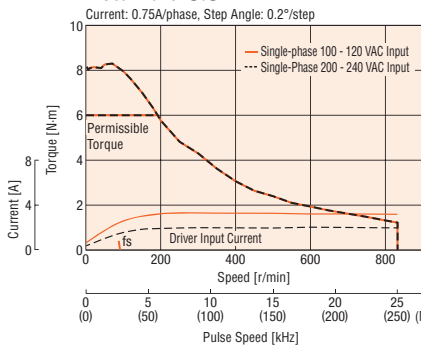

RKS596 Gear Ratio: 7.2

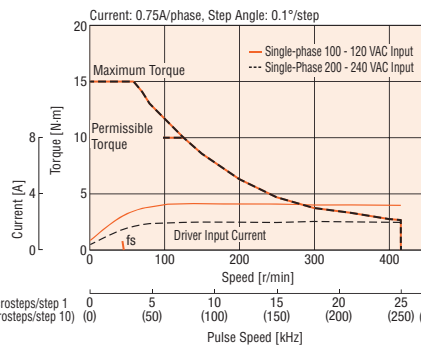

RKS596 Gear Ratio: 10

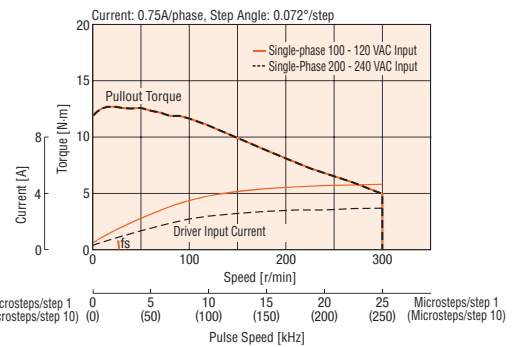

RKS596 Gear Ratio: 20

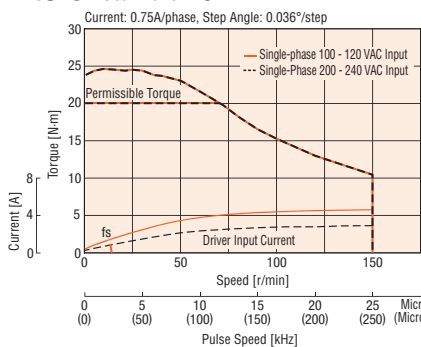

RKS596 Gear Ratio: 30

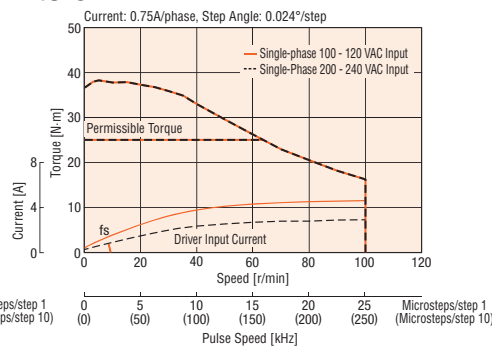

Note

● Pay attention to heat dissipation from the motor as there will be a considerable amount of heat under certain conditions. Be sure to keep the temperature of the motor case under 100°C.

[When conforming to the UL or CSA Standards, it is required to keep the temperature of the motor case at 75°C or less, since the motor is recognized as Thermal class 105 (A).]

PS Geared Type Frame Size 42 mm

PS Geared Type with Electromagnetic Brake Frame Size 42 mm

Specifications RoHS



Product Name	Built-in Controller Type	RKS545 D-PS5	RKS545 D-PS7.2	RKS545 D-PS10	RKS543 D-PS25	RKS543 D-PS36	RKS543 D-PS50
	Pulse Input Type	RKS545 -PS5	RKS545 -PS7.2	RKS545 -PS10	RKS543 -PS25	RKS543 -PS36	RKS543 -PS50
Maximum Holding Torque	N·m	1	1.5	2.5	2.5	3	3
Rotor Inertia	J : kg·m ²	64×10 ⁻⁷ [79×10 ⁻⁷]*1			30×10 ⁻⁷ [45×10 ⁻⁷]*1		
Rated Current	A / Phase	0.35					
Basic Step Angle		0.144°	0.1°	0.072°	0.0288°	0.02°	0.0144°
Gear Ratio		5	7.2	10	25	36	50
Permissible Torque*2	N·m	1	1.5	2.5	2.5	3	3
Maximum Torque*2	N·m	1.5	2	6	6	6	6
Holding Torque at Power ON	N·m	0.74	1.07	1.49	1.85	2.6	3
Motor Standstill Electromagnetic Brake	N·m	0.74	1.07	1.49	1.85	2.6	3
Permissible Speed Range	r/min	0~600	0~416	0~300	0~120	0~83	0~60
Backlash	arc min	25(0.42°)					
Power Supply	Voltage / Frequency	Single-Phase 100-120 VAC, Single-Phase 200-240 VAC -15~+10% 50/60 Hz					
Input	Input Single-Phase 100-120 VAC	1.9			2.1		
	Current A Single-Phase 200-240 VAC	1.2			1.3		
Excitation Mode		Microstep					
Control Power Supply*3		24 VDC±5% 0.2 A					
Electromagnetic Brake*4	Power Supply Input	24 VDC±5%*5 0.08 A					

Definition → Refer to page 22

● Either **A** (single shaft), **B** (double shaft) or **M** (electromagnetic brake) indicating the configuration is entered where the box is located within the product name.

Either **A** (Single-Phase 100-120 VAC) or **C** (Single-Phase 200-240 VAC) indicating the configuration is entered where is located within the product name.

A number indicating the desired length of **1** (1 m), **2** (2 m) or **3** (3 m) for the cable included with the product is entered where the box is located within the product name.

*1 The values inside the brackets [] represent the specification for the electromagnetic brake type.

*2 Permissible Torque and Maximum Torque shown above is value recorded at the Gear. Refer to Speed -Torque Specification graph for output torque of Geared Motor.

*3 For Built-in Controller package, the control power supply is required.

*4 For pulse input package, a separate power supply for electromagnetic brakes is required.

*5 If the wiring distance between the motor and driver is extended to 15 m or longer by using an accessory cable (sold separately), the 24 VDC±4% specification applies.

Speed -Torque Characteristics fs: Maximum Starting Frequency

RKS545 Gear Ratio: 5

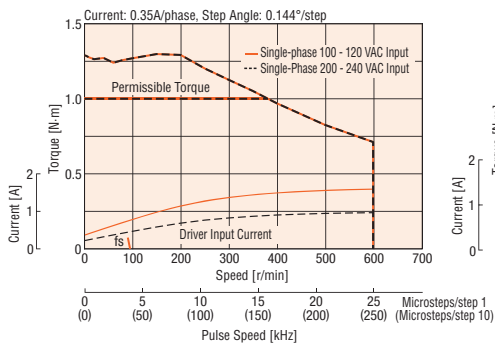

RKS545 Gear Ratio: 7.2

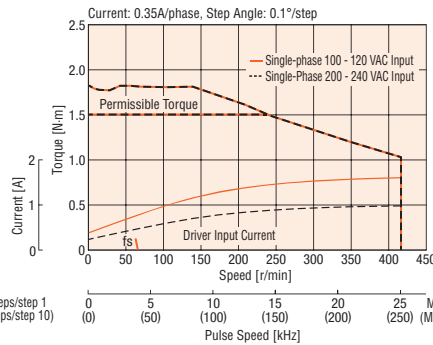

RKS545 Gear Ratio: 10

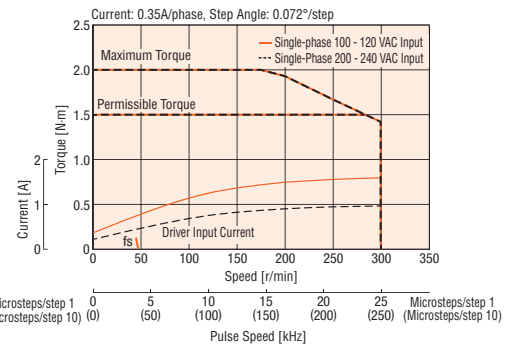

RKS543 Gear Ratio: 25

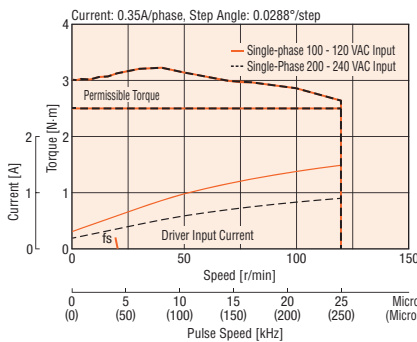

RKS543 Gear Ratio: 36

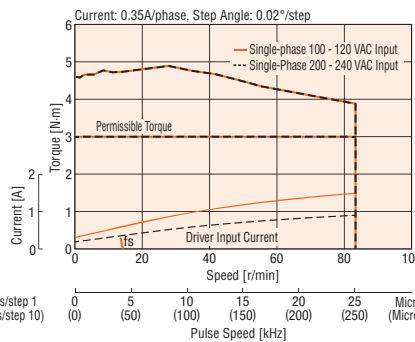

RKS543 Gear Ratio: 50

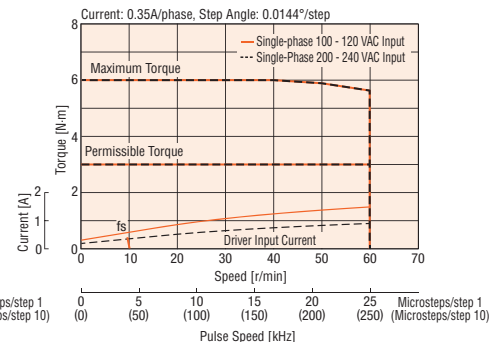

Note

● Pay attention to heat dissipation from the motor as there will be a considerable amount of heat under certain conditions. Be sure to keep the temperature of the motor case under 100°C.

[When conforming to the UL or CSA Standards, it is required to keep the temperature of the motor case at 75°C or less, since the motor is recognized as Thermal class 105 (A).]

PS Geared Type Frame Size 60 mm

PS Geared Type with Electromagnetic Brake Frame Size 60 mm

Specifications RoHS



Product Name	Built-In Controller Type	RKS566 D-PS5 ◇	RKS566 D-PS7.2 ◇	RKS566 D-PS10 ◇	RKS564 D-PS25 ◇	RKS564 D-PS36 ◇	RKS564 D-PS50 ◇
	Pulse Input Type	RKS566 -PS5 ◇	RKS566 -PS7.2 ◇	RKS566 -PS10 ◇	RKS564 -PS25 ◇	RKS564 -PS36 ◇	RKS564 -PS50 ◇
Maximum Holding Torque	N·m	3.5	4	5	8		
Rotor Inertia	J : kg·m ²	270×10 ⁻⁷ [430×10 ⁻⁷]*1			160×10 ⁻⁷ [320×10 ⁻⁷]*1		
Rated Current	A / Phase	0.75					
Basic Step Angle		0.144°	0.1°	0.072°	0.0288°	0.02°	0.0144°
Gear Ratio		5	7.2	10	25	36	50
Permissible Torque*2	N·m	3.5	4	5	8		
Maximum Torque*2	N·m	7	9	11	16	20	
Holding Torque at Power ON	N·m	2.7	3.9	5	7.2	8	
Motor Standstill Electromagnetic Brake	N·m	2.7	3.9	5	7.2	8	
Permissible Speed Range	r/min	0~600	0~416	0~300	0~120	0~83	0~60
Backlash	arc min	7(0.12°)			9(0.15°)		
Power Supply	Voltage / Frequency	Single-Phase 100-120 VAC, Single-Phase 200-240 VAC -15~+10% 50/60 Hz					
Input	Single-Phase 100-120 VAC	3.8			4.0		
	Current A	2.4			2.4		
Excitation Mode		Microstep					
Control Power Supply*3		24 VDC±5% 0.2 A					
Electromagnetic Brake*4	Power Supply Input	24 VDC±5%*5 0.25 A					

Definition → Refer to page 22

● Either **A** (single shaft), **B** (double shaft) or **M** (electromagnetic brake) indicating the configuration is entered where the box is located within the product name.

Either **A** (Single-Phase 100-120 VAC) or **C** (Single-Phase 200-240 VAC) indicating the configuration is entered where is located within the product name.

A number indicating the desired length of **1** (1 m), **2** (2 m) or **3** (3 m) for the cable included with the product is entered where the box is located within the product name.

*1 The values inside the brackets [] represent the specification for the electromagnetic brake type.

*2 Permissible Torque and Maximum Torque shown above is value recorded at the Gear. Refer to Speed -Torque Specification graph for output torque of Geared Motor.

*3 For Built-in Controller package, the control power supply is required.

*4 For pulse input package, a separate power supply for electromagnetic brakes is required.

*5 If the wiring distance between the motor and driver is extended to 15 m or longer by using an accessory cable (sold separately), the 24 VDC±4% specification applies.

Speed -Torque Characteristics fs: Maximum Starting Frequency

RKS566 Gear Ratio: 5

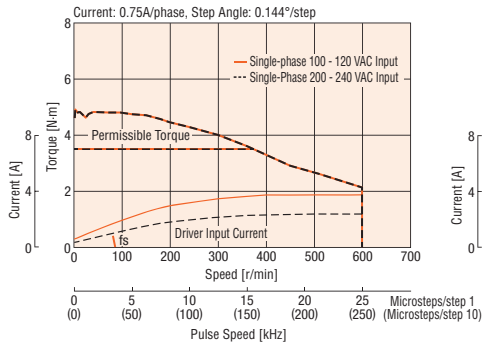

RKS566 Gear Ratio: 7.2

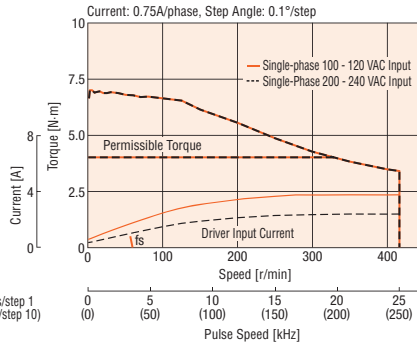

RKS566 Gear Ratio: 10

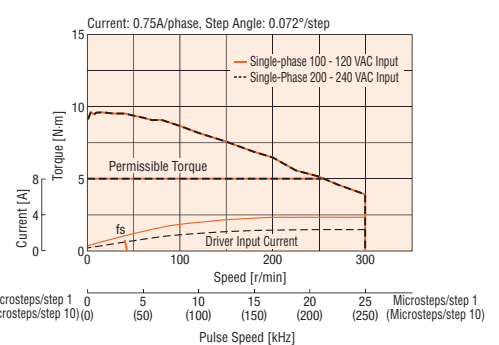

RKS564 Gear Ratio: 25

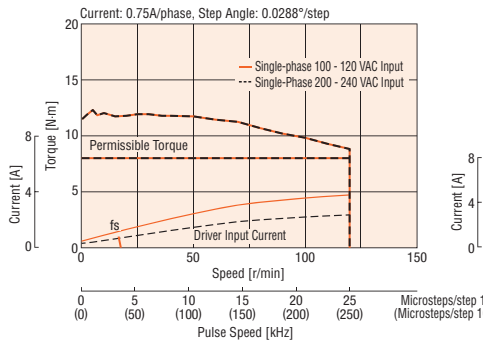

RKS564 Gear Ratio: 36

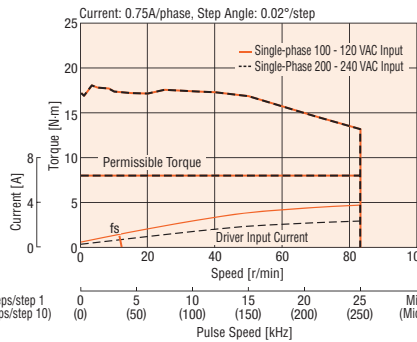

RKS564 Gear Ratio: 50

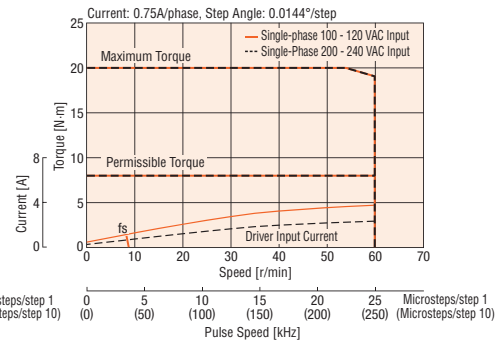

Note

● Pay attention to heat dissipation from the motor as there will be a considerable amount of heat under certain conditions. Be sure to keep the temperature of the motor case under 100°C.

[When conforming to the UL or CSA Standards, it is required to keep the temperature of the motor case at 75°C or less, since the motor is recognized as Thermal class 105 (A).]

PS Geared Type Frame Size 90 mm

PS Geared Type with Electromagnetic Brake Frame Size 90 mm

Specifications (RoHS)



Product Name	Built-In Controller Type	RKS599 <input type="checkbox"/> D-PS5- <input type="checkbox"/>	RKS599 <input type="checkbox"/> D-PS7.2- <input type="checkbox"/>	RKS599 <input type="checkbox"/> D-PS10- <input type="checkbox"/>	RKS596 <input type="checkbox"/> D-PS25- <input type="checkbox"/>	RKS596 <input type="checkbox"/> D-PS36- <input type="checkbox"/>	RKS596 <input type="checkbox"/> D-PS50- <input type="checkbox"/>
	Pulse InputType	RKS599 <input type="checkbox"/> -PS5- <input type="checkbox"/>	RKS599 <input type="checkbox"/> -PS7.2- <input type="checkbox"/>	RKS599 <input type="checkbox"/> -PS10- <input type="checkbox"/>	RKS596 <input type="checkbox"/> -PS25- <input type="checkbox"/>	RKS596 <input type="checkbox"/> -PS36- <input type="checkbox"/>	RKS596 <input type="checkbox"/> -PS50- <input type="checkbox"/>
Maximum Holding Torque	N·m	14	20	36	37		
Rotor Inertia	J : kg·m ²	2200×10 ⁻⁷ [3300×10 ⁻⁷]*1			1100×10 ⁻⁷ [2200×10 ⁻⁷]*1		
Rated Current	A / Phase	0.75					
Basic Step Angle		0.144°	0.1°	0.072°	0.0288°	0.02°	0.0144°
Gear Ratio		5	7.2	10	25	36	50
Permissible Torque*2	N·m	14	20	37			
Maximum Torque*2	N·m	28	35	56	60		
Holding Torque at Power ON	N·m	12.5	18	20	18.5	26	37
Motor Standstill Electromagnetic Brake	N·m	12.5	18	20	18.5	26	37
Permissible Speed Range	r/min	0~300	0~208	0~150	0~120	0~83	0~60
Backlash	arc min	7(0.12°)			9(0.15°)		
Power Supply Voltage / Frequency		Single-Phase 100-120 VAC, Single-Phase 200-240 VAC -15~+10% 50/60 Hz					
Power Supply Input	Input	3.5			4.9		
	Current A	2.2			3.0		
Excitation Mode		Microstep					
Control Power Supply*3		24 VDC±5% 0.2 A					
Electromagnetic Brake*4	Power Supply Input	24 VDC±5%*5 0.42 A					

Definition → Refer to page 22

● Either **A** (single shaft), **B** (double shaft) or **M** (electromagnetic brake) indicating the configuration is entered where the box is located within the product name.

Either **A** (Single-Phase 100-120 VAC) or **C** (Single-Phase 200-240 VAC) indicating the configuration is entered where is located within the product name.

A number indicating the desired length of **1** (1 m), **2** (2 m) or **3** (3 m) for the cable included with the product is entered where the box is located within the product name.

*1 The values inside the brackets [] represent the specification for the electromagnetic brake type.

*2 Permissible Torque and Maximum Torque shown above is value recorded at the Gear. Refer to Speed -Torque Specification graph for output torque of Geared Motor.

*3 For Built-in Controller package, the control power supply is required.

*4 For pulse input package, a separate power supply for electromagnetic brakes is required.

*5 If the wiring distance between the motor and driver is extended to 15 m or longer by using an accessory cable (sold separately), the 24 VDC±4% specification applies.

Speed -Torque Characteristics fs: Maximum Starting Frequency

RKS599 Gear Ratio: 5

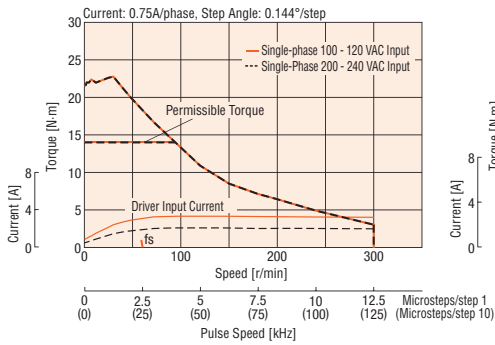

RKS599 Gear Ratio: 7.2

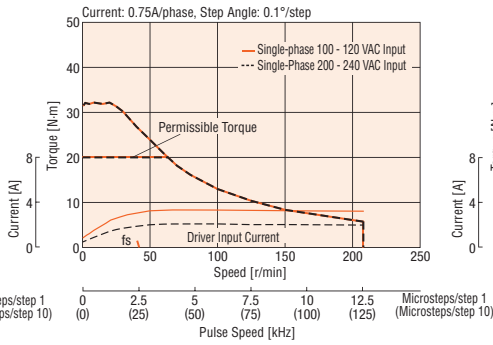

RKS599 Gear Ratio: 10

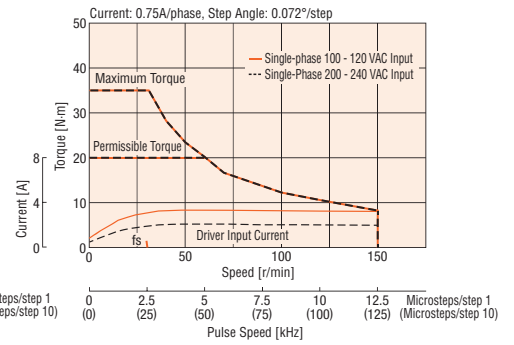

RKS596 Gear Ratio: 25

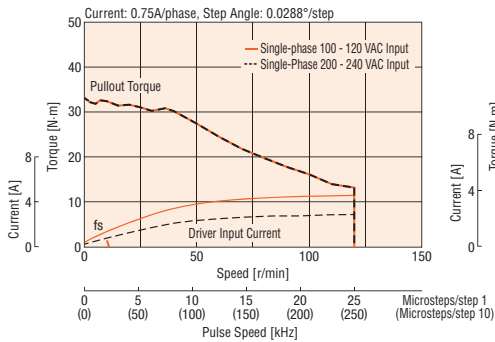

RKS596 Gear Ratio: 36

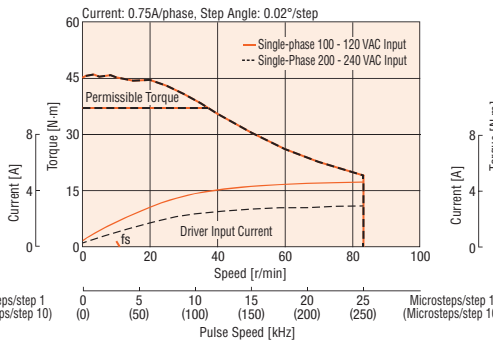

RKS596 Gear Ratio: 50

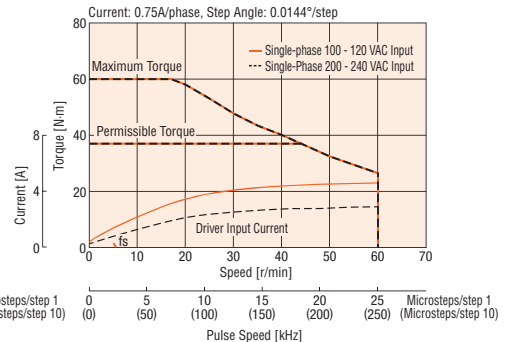

Note

● Pay attention to heat dissipation from the motor as there will be a considerable amount of heat under certain conditions. Be sure to keep the temperature of the motor case under 100°C.

[When conforming to the UL or CSA Standards, it is required to keep the temperature of the motor case at 75°C or less, since the motor is recognized as Thermal class 105 (A).]

Harmonic Geared Type Frame Size 42 mm, 60 mm, 90 mm

Harmonic Geared Type with Electromagnetic Brake Frame Size 42 mm, 60 mm, 90 mm

Specifications RoHS



Product Name	Built-In Controller Type	RKS543 D -HS50- ◇	RKS543 D -HS100- ◇	RKS564 D -HS50- ◇	RKS564 D -HS100- ◇	RKS596 D -HS50- ◇	RKS596 D -HS100- ◇
	Pulse Input Type	RKS543 H HS50- ◇	RKS543 H HS100- ◇	RKS564 H HS50- ◇	RKS564 H HS100- ◇	RKS596 H HS50- ◇	RKS596 H HS100- ◇
Maximum Holding Torque	N·m	3.5	5	7	10	33	52
Rotor Inertia	J : kg·m ²	47×10 ⁻⁷ [62×10 ⁻⁷]*1		195×10 ⁻⁷ [355×10 ⁻⁷]*1		1300×10 ⁻⁷ [2400×10 ⁻⁷]*1	
Rated Current	A / Phase	0.35			0.75		
Basic Step Angle		0.0144°	0.072°	0.0144°	0.0072°	0.0144°	0.0072°
Gear Ratio		50	100	50	100	50	100
Permissible Torque	N·m	3.5	5	7	10	33	52
Maximum Torque*2	N·m	8.3	11	23	36	73	107
Holding Torque at Power ON	N·m	3.5	5	7	10	33	52
Motor Standstill Electromagnetic Brake	N·m	3.5	5	7	10	33	52
Permissible Speed Range	r/min	0~70	0~35	0~70	0~35	0~70	0~35
Lost Motion (Load Torque)	arc min	1.5 maximum (±0.16 N·m)	1.5 maximum (±0.20 N·m)	0.7 maximum (±0.28 N·m)	0.7 maximum (±0.39 N·m)	0.7 maximum (±1.2 N·m)	0.7 maximum (±1.2 N·m)
Power Supply Input	Voltage / Frequency	Single-Phase 100-120 VAC, Single-Phase 200-240 VAC -15~+10% 50/60 Hz					
	Input Current A	2.1		4.0		4.9	
Excitation Mode	Single-Phase 100-120 VAC	1.3		2.4		3.0	
	Single-Phase 200-240 VAC						
Control Power Supply*3		24 VDC±5% 0.2 A					
Electromagnetic Brake*4	Power Supply Input	24 VDC±5%*5 0.08 A		24 VDC±5%*5 0.25 A		24 VDC±5%*5 0.42 A	

Definition → Refer to page 22

● Either **A** (single shaft), **B** (double shaft) or **M** (electromagnetic brake) indicating the configuration is entered where the box is located within the product name.

Either **A** (Single-Phase 100-120 VAC) or **C** (Single-Phase 200-240 VAC) indicating the configuration is entered where is located within the product name.

A number indicating the desired length of **1** (1 m), **2** (2 m) or **3** (3 m) for the cable included with the product is entered where the box ◇ is located within the product name.

*1 The values inside the brackets [] represent the specification for the electromagnetic brake type.

*2 Maximum Torque shown above is value recorded at the Gear. Refer to Speed-Torque Specification graph for output torque of Geared Motor.

*3 For Built-in Controller package, the control power supply is required.

*4 For pulse input package, a separate power supply for electromagnetic brakes is required.

*5 If the wiring distance between the motor and driver is extended to 15 m or longer by using an accessory cable (sold separately), the 24 VDC±4% specification applies.

Note

● The inertia represents a sum of the inertia of the harmonic gear converted to a motor shaft value, and the rotor inertia

Speed -Torque Characteristics fs: Maximum Starting Frequency

RKS543 Gear Ratio: 50

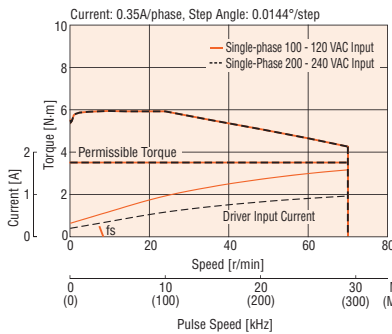

RKS564 Gear Ratio: 50

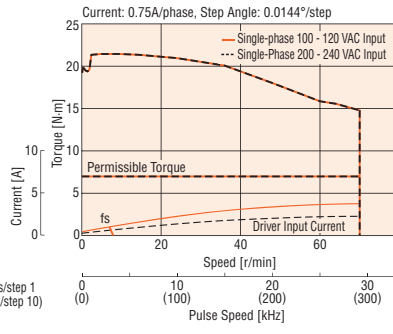

RKS596 Gear Ratio: 50

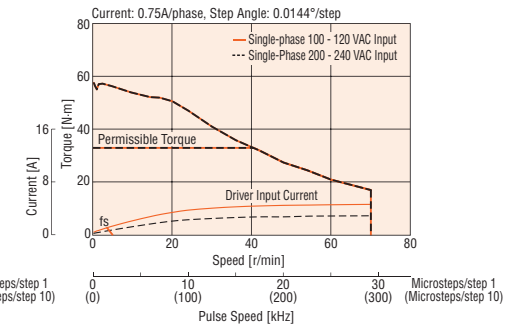

RKS543 Gear Ratio: 100

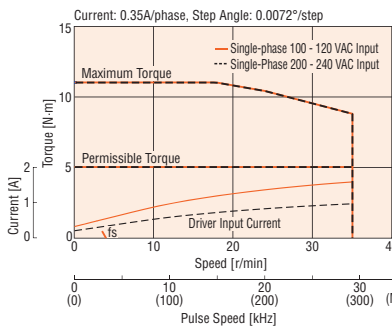

RKS564 Gear Ratio: 100

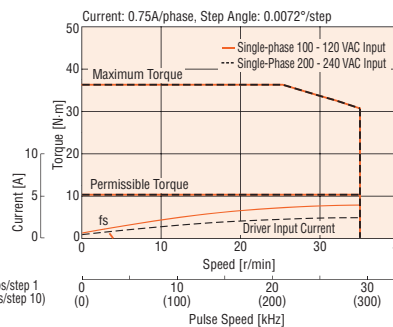

RKS596 Gear Ratio: 100

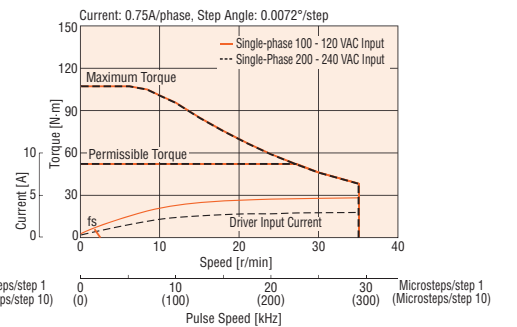

Note

● Pay attention to heat dissipation from the motor as there will be a considerable amount of heat under certain conditions. Be sure to keep the temperature of the motor case under 100°C.

● For the Harmonic Gear operation, be sure to keep the temperature of the gear case under 70°C to prevent deterioration of grease applied to the gear.

[When conforming to the UL or CSA Standards, it is required to keep the temperature of the motor case at 75°C or less, since the motor is recognized as Thermal class 105 (A).]

Driver Specification

	Built-in Controller type	Pulse-input Type
Maximum Input Pulse Frequency	–	Line Driver Output from controller: 500kHz (at 50% duty) Open-collector Output from controller: 250kHz (at 50% duty) Active low pulse-input
Input Signal	Photocoupler input Input signal voltage : 11.4 VDC~26.4 VDC	Photocoupler, Open-collector output: 11.4 VDC~26.4 VDC (AWO, CS, FREE, ALM-RST) Photocoupler, Open-collector output: 3 VDC~5.25 VDC (CW (PLS) + 5 V, CCW (DIR) + 5 V) Photocoupler, Open-collector output: 21.6 VDC~26.4 VDC (CW (PLS) + 24 V, CCW (DIR) + 24 V)
Output Signal	Photocoupler · Open-collector output External use condition: 30 VDC maximum, 10 mA maximum	Photocoupler · Open-collector output External use condition: 30 VDC maximum, 10 mA maximum (READY, ALM, TIM)
Number of Positioning Program	64	–
Positioning Operation	One-shot operation, Linked operation, Linked operation 2, Sequential mode, Direct mode	–
Other operation	Continuous Operation, JOG Operation, Return-To-Home Operation, Test Operation	–
Control Module OPX-2A	○	–
Data Setting Software MEXE02	○	–

Built-In Controller Type RS-485 Communication Specifications

Protocol	Modbus RTU mode
Electrical Characteristics	EIA-485 compliance Shielded twisted-pair wire (TIA/EIA-568B CAT5e or greater recommended) is used up to a total extension length of 50 m.
Transmission/ Reception Mode	Half-duplex communication Asynchronous mode (data: 8-bit, stop bit: 1-bit/2-bit, parity: none/odd/even)
Baud Rate	9600 bps/19200 bps/38400 bps/57600 bps/115200 bps
Connection Type	Up to 31 units can be connected to one programmable controller (master equipment).

General Specifications

	Motor	Driver	
		Built-In Controller Type	Pulse Input Type
Thermal Class	130 (B) [Recognized as 105 (A) by UL]	–	
Insulation Resistance	100 MΩ or more when 500 VDC megger is applied between the following places: · Case – Motor windings · Case – Electromagnetic brake windings*1	100 MΩ or more when 500 VDC megger is applied between the following places: · PE terminal – Power supply terminal · Signal I/O terminal – Power supply terminal	
Dielectric Strength	Sufficient to withstand the following for 1 minute: · Case – Motor windings 1.5 kVAC 50 Hz or 60 Hz · Case – Electromagnetic brake windings 1.5 kVAC 50 Hz or 60 Hz*1	Sufficient to withstand the following for 1 minute: · PE terminal – Power supply terminal 1.5 kVAC 50 Hz or 60 Hz · Signal I/O terminal – Power supply terminal 1.8 kVAC 50 Hz or 60 Hz	· PE terminal – Power supply terminal 1.8 kVAC 50 Hz or 60 Hz · Signal I/O terminal – Power supply terminal 1.9 kVAC 50 Hz or 60 Hz
Operating Environment (In Operation)	Ambient Temperature	–10~+50°C (non-freezing): Standard Type, TS and PS Geared Type 0~+50°C (non-freezing): Package with Encoder 0~+40°C (non-freezing): Harmonic geared type	
	Ambient Humidity	85% or less (non-condensing)	
	Atmosphere	No corrosive gases, dust. Avoid contact with water or oil.	
Temperature Rise	Temperature rise of the windings are 80°C or less. Measured at rated current, at standstill, five phases energized measured (by the resistance change method).	–	
Degree of Protection	IP20	IP10	IP20
Stop Position Accuracy*3	±3 arc minutes (±0.05°)		
Shaft Runout	0.05 T.I.R (mm)*4	–	
Radial Play*5	0.025 mm Max. (Load 5 N)	–	
Axial Play*6	0.075 mm Max. (Load 10 N)	–	
Concentricity for Shaft in the Mounting Pilot	0.075 T.I.R (mm)*4	–	
Perpendicularity for Shaft of the Mounting Surface	0.075 T.I.R (mm)*4	–	

*1 Only for Built-in Controller Package

*2 When attaching a heat sink 200 mm x 200 mm x 2 mm, made from aluminum plate or higher.

*3 This value is measured at step angle 0.72°, under no load. (The value changes depends on the size of the load.)

*4 T.I.R. (Total Indicator Reading) : The total dial gauge reading when the measurement section is rotated one revolution centered on the reference axis center.

*5 Radial Play : Displacement in shaft position in the radial direction, when a 5 N load is applied in the vertical direction to the tip of the motor's shaft.

*6 Axial Play : Displacement in shaft position in the axial direction, when a 10 N load is applied to the motor's shaft in the axial direction.

Note

● Do not measure insulation resistance or perform the dielectric strength test while the motor and driver are connected.

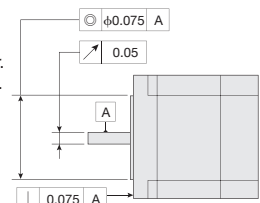

Encoder Specifications

Resolution	500 P/R
Output mode	Incremental
Output signal	3 channels
Output Circuit type	Line Driver

Permissible Radial Load and Permissible Axial Load

Unit=N

Type	Frame Size	Model	Gear Ratio	Permissible Radial Load					Permissible Axial Load
				Distance from tip of shaft mm					
				0	5	10	15	20	
Standard Type	42 mm	RKS54	-	35	44	58	85	-	15
	60 mm	RKS56		90	100	130	180	270	30
	85 mm	RKS59		260	290	340	390	480	60
TS Geared Type	42 mm	RKS54	3.6, 7.2, 10 20, 30	20	30	40	50	-	15
				40	50	60	70	-	
	60 mm	RKS56	3.6, 7.2, 10 20, 30	120	135	150	165	180	40
				170	185	200	215	230	
	90 mm	RKS59	3.6, 7.2, 10 20, 30	300	325	350	375	400	150
				400	450	500	550	600	
PS Geared Type	42 mm	RKS54	5 7.2 10 25 36 50	70	80	95	120	-	100
				80	90	110	140	-	
				85	100	120	150	-	
				120	140	170	210	-	
				130	160	190	240	-	
				150	170	210	260	-	
	60 mm	RKS56	5 7.2 10 25 36 50	170	200	230	270	320	200
				200	220	260	310	370	
				220	250	290	350	410	
				300	340	400	470	560	
				340	380	450	530	630	
				380	430	500	600	700	
	90 mm	RKS59	5 7.2 10 25 36 50	380	420	470	540	630	600
				430	470	530	610	710	
				480	530	590	680	790	
				650	720	810	920	1070	
				730	810	910	1040	1210	
				820	910	1020	1160	1350	
Harmonic Geared Type	42 mm	RKS54	50, 100	180	220	270	360	510	220
	60 mm	RKS56		320	370	440	550	720	450
	90 mm	RKS59		1090	1150	1230	1310	1410	1300

● PS geared type, when either the permissible radial load or permissible axial load are added, shall have a lifespan value satisfying 20,000 hours. For the gearhead lifespan please contact the nearest Oriental Motor sales office.

Radial Load and Axial Load

Distance from Shaft End [mm]

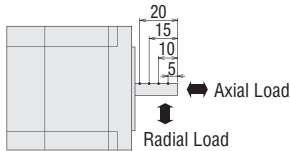

Rotation direction

This indicates the rotation direction as viewed from the output shaft side of the motor (factory setting).

The rotation direction of the output gear shaft relative to the standard type motor output shaft varies depending on the gear type and gear ratio. Please check the following table.

Type	Gear Ratio	Rotation direction Relative to Motor Output Shaft
TS Geared	3.6, 7.2, 10	Same direction
	20, 30	Opposite direction
PS Geared	All gear ratios	Same direction
Harmonic Geared	All gear ratios	Opposite direction

Standard Type Motor

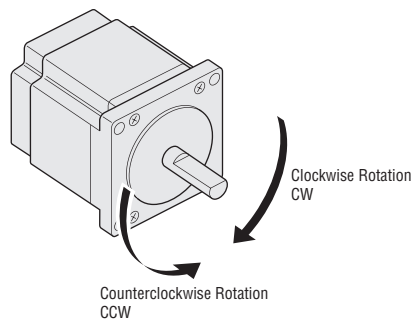

Dimensions (Unit = mm)

Motors

◇ Standard Type

Frame Size 42 mm

Product Name		Motor Product Name	L1	L2	Mass kg
Built-In Controller	Pulse Input				
RKS543A D ◇	RKS543A ◇	PKE543AC	34	-	0.26
RKS543B D ◇	RKS543B ◇	PKE543BC		49	
RKS544A D ◇	RKS544A ◇	PKE544AC	40	-	0.32
RKS544B D ◇	RKS544B ◇	PKE544BC		55	
RKS545A D ◇	RKS545A ◇	PKE545AC	46	-	0.38
RKS545B D ◇	RKS545B ◇	PKE545BC		61	

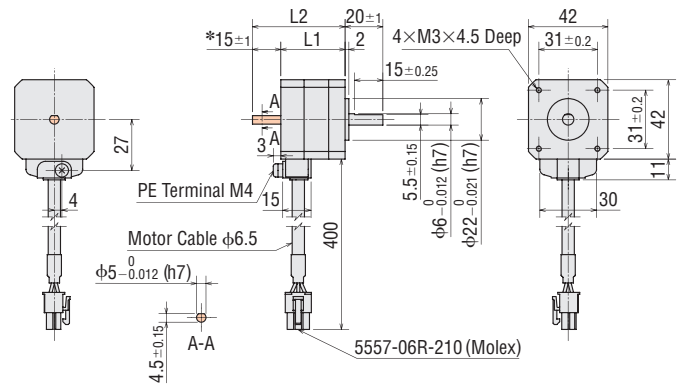

* Length of milling cut for double shaft type is 15±0.25.

Frame Size 60 mm

Product Name		Motor Product Name	L1	L2	Mass kg
Built-In Controller	Pulse Input				
RKS564A D ◇	RKS564A ◇	PKE564AC	48.5	-	0.7
RKS564B D ◇	RKS564B ◇	PKE564BC		69.5	
RKS566A D ◇	RKS566A ◇	PKE566AC	59.5	-	0.9
RKS566B D ◇	RKS566B ◇	PKE566BC		80.5	
RKS569A D ◇	RKS569A ◇	PKE569AC	89	-	1.4
RKS569B D ◇	RKS569B ◇	PKE569BC		110	

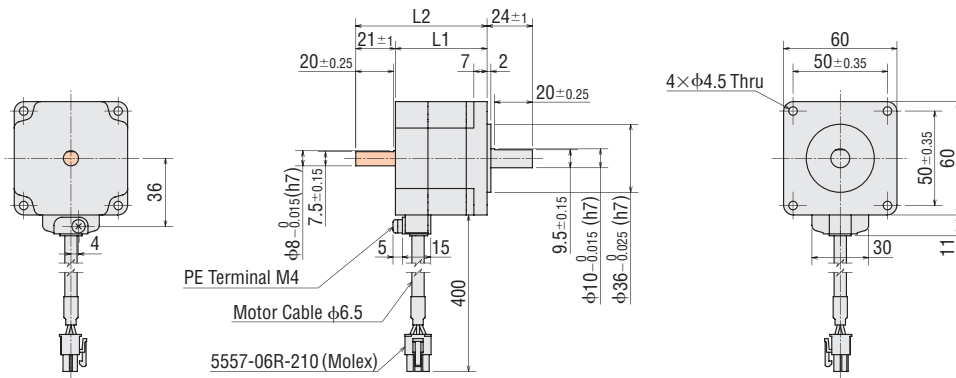

Frame Size 85 mm

Product Name		Motor Product Name	L1	L2	Mass kg
Built-In Controller	Pulse Input				
RKS596A D ◇	RKS596A ◇	PKE596AC	68	-	1.9
RKS596B D ◇	RKS596B ◇	PKE596BC		100	
RKS599A D ◇	RKS599A ◇	PKE599AC	98	-	3.0
RKS599B D ◇	RKS599B ◇	PKE599BC		130	
RKS5913A D ◇	RKS5913A ◇	PKE5913AC	128	-	4.1
RKS5913B D ◇	RKS5913B ◇	PKE5913BC		160	

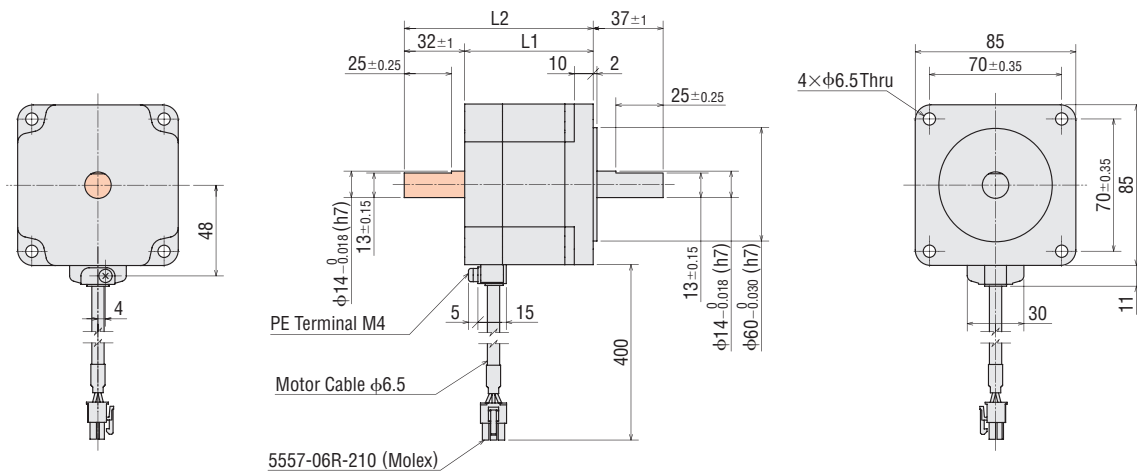

- Either **A** (Single-Phase 100-120 VAC) or **C** (Single-Phase 200-240 VAC) indicating the configuration is entered where is located within the product name.
- A number indicating the desired length of **1** (1 m), **2** (2 m) or **3** (3 m) for the cable included with the product is entered where the box is located within the product name.
- These dimensions are for double shaft models. For single shaft models, ignore the areas.

◇ Standard Type with Electromagnetic Brake

Frame Size 42 mm

Product Name		Motor Product Name	L	Mass kg
Built-In Controller	Pulse Input			
RKS543M D-◇	RKS543M -◇	PKE543MC	64	0.40
RKS544M D-◇	RKS544M -◇	PKE544MC	70	0.46
RKS545M D-◇	RKS545M -◇	PKE545MC	75	0.52

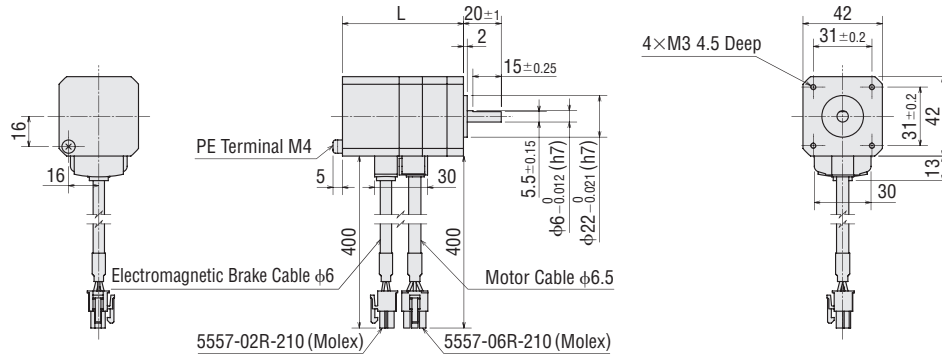

Frame Size 60 mm

Product Name		Motor Product Name	L	Mass kg
Built-In Controller	Pulse Input			
RKS564M D-◇	RKS564M -◇	PKE564MC	83.5	1.0
RKS566M D-◇	RKS566M -◇	PKE566MC	94.5	1.2
RKS569M D-◇	RKS569M -◇	PKE569MC	124	1.7

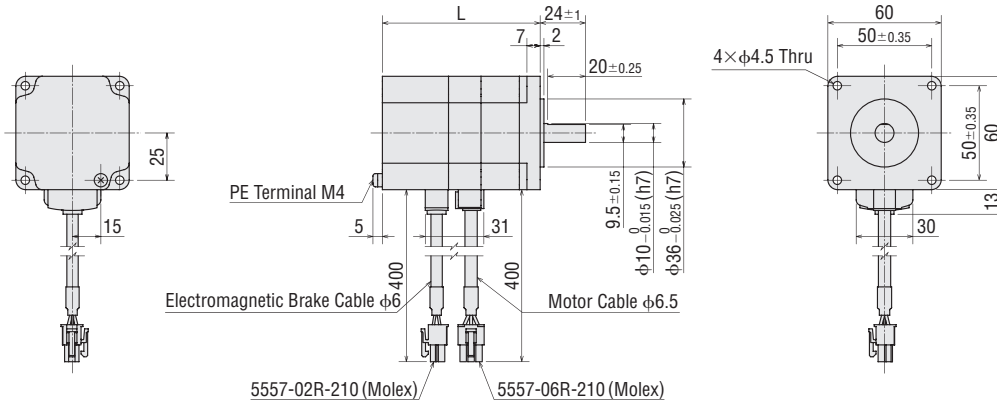

Frame Size 85 mm

Product Name		Motor Product Name	L	Mass kg
Built-In Controller	Pulse Input			
RKS596M D-◇	RKS596M -◇	PKE596MC	118	2.7
RKS599M D-◇	RKS599M -◇	PKE599MC	148	3.8
RKS5913M D-◇	RKS5913M -◇	PKE5913MC	178	4.9

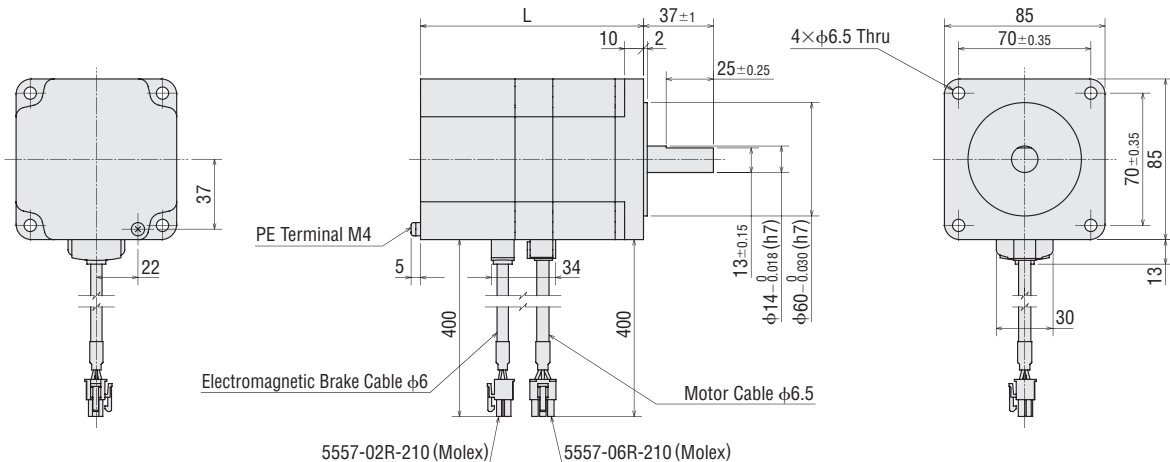

● Either **A** (Single-Phase 100-120 VAC) or **C** (Single-Phase 200-240 VAC) indicating the configuration is entered where **□** is located within the product name.
 ● A number indicating the desired length of **1** (1 m), **2** (2 m) or **3** (3 m) for the cable included with the product is entered where the box **◇** is located within the product name.

◇ Standard Type with Encoder

Frame Size 42 mm

Product Name	Motor Product Name	L	Mass kg
RKS543R D2 -◇	PKE543RC2	56	0.32
RKS544R D2 -◇	PKE544RC2	62	0.38
RKS545R D2 -◇	PKE545RC2	68	0.44

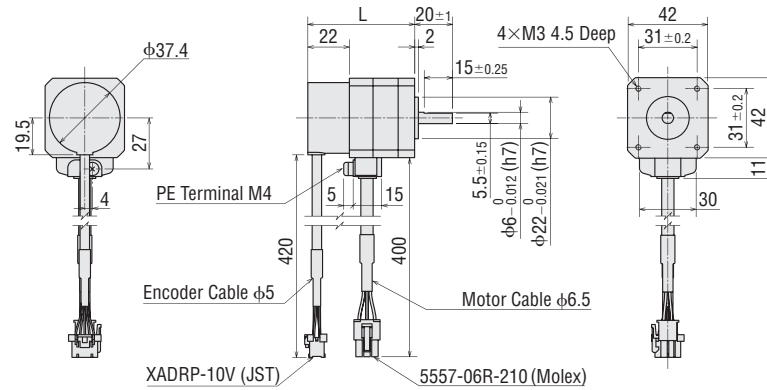

Frame Size 60 mm

Product Name	Motor Product Name	L	Mass kg
RKS564R D2 -◇	PKE564RC2	70.5	0.76
RKS566R D2 -◇	PKE566RC2	81.5	0.96
RKS569R D2 -◇	PKE569RC2	111	1.5

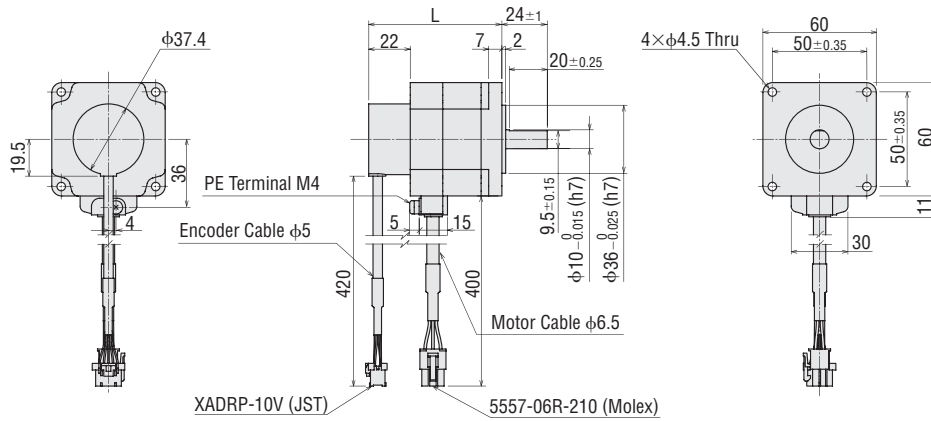

Frame Size 85 mm

Product Name	Motor Product Name	L	Mass kg
RKS596R D2 -◇	PKE596RC2	90	2.0
RKS599R D2 -◇	PKE599RC2	120	3.1
RKS5913R D2 -◇	PKE5913RC2	150	4.2

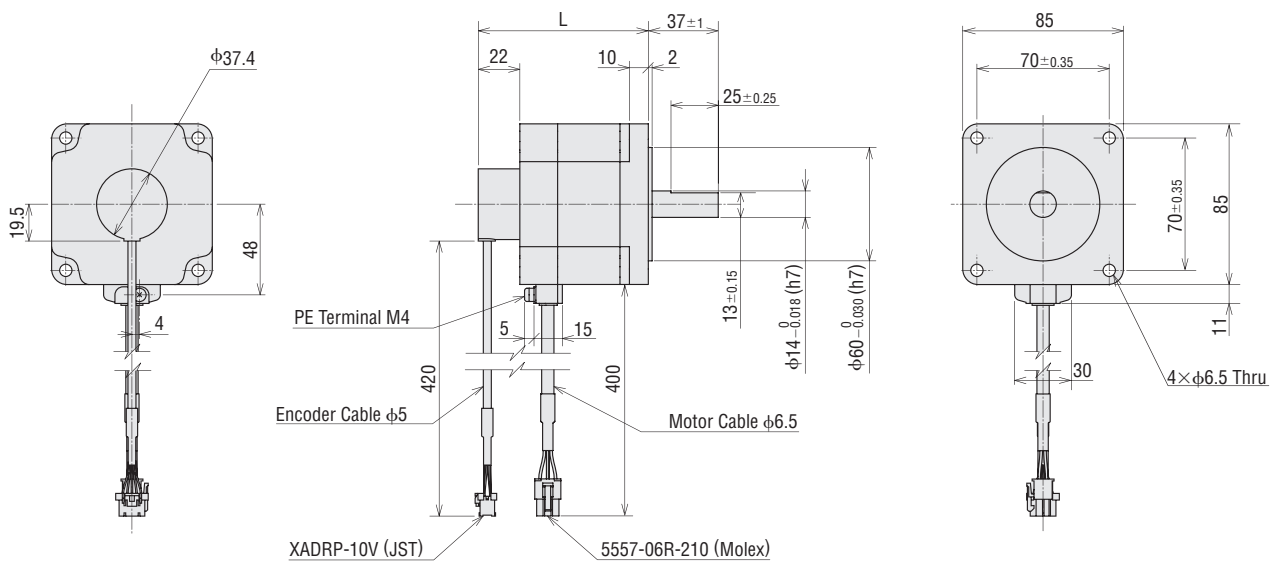

- Either **A** (Single-Phase 100-120 VAC) or **C** (Single-Phase 200-240 VAC) indicating the configuration is entered where **□** is located within the product name.
- A number indicating the desired length of **1** (1 m), **2** (2 m) or **3** (3 m) for the cable included with the product is entered where the box **◇** is located within the product name.

◇ TS Geared Type

Frame Size 42 mm

Product Name		Motor Product Name	Gear Ratio	Mass kg
Built-In Controller	Pulse Input			
RKS543A D-TS ◇	RKS543A TS ◇	PKE543AC-TS	3.6, 7.2, 10, 20, 30	0.41
RKS543B D-TS ◇	RKS543B TS ◇	PKE543BC-TS		

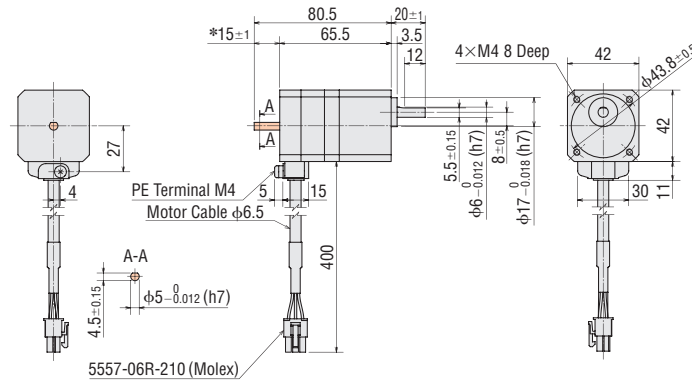

* Length of milling cut for double shaft type is 15±0.25.

Frame Size 60 mm

Product Name		Motor Product Name	Gear Ratio	Mass kg
Built-In Controller	Pulse Input			
RKS564A D-TS ◇	RKS564A TS ◇	PKE564AC-TS	3.6, 7.2, 10, 20, 30	1.1
RKS564B D-TS ◇	RKS564B TS ◇	PKE564BC-TS		

● Mounting Screw: M4×60 P0.7 (4 screws are included with the product)

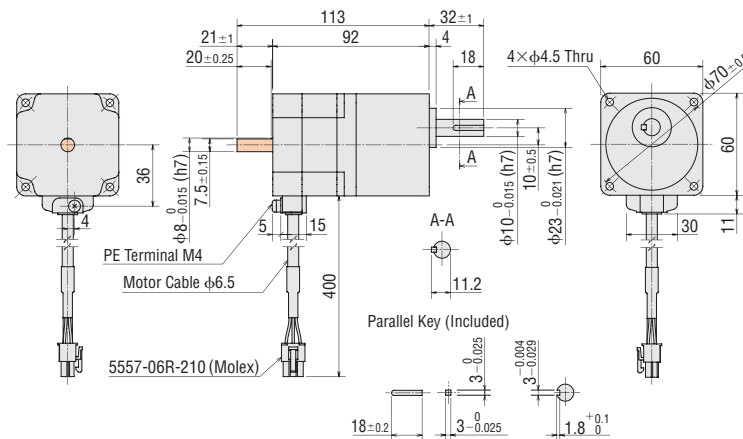

Frame Size 90 mm

Product Name		Motor Product Name	Gear Ratio	Mass kg
Built-In Controller	Pulse Input			
RKS596A D-TS ◇	RKS596A TS ◇	PKE596AC-TS	3.6, 7.2, 10, 20, 30	3.1
RKS596B D-TS ◇	RKS596B TS ◇	PKE596BC-TS		

● Mounting Screw: M8×90 P1.25 (4 screws are included with the product)

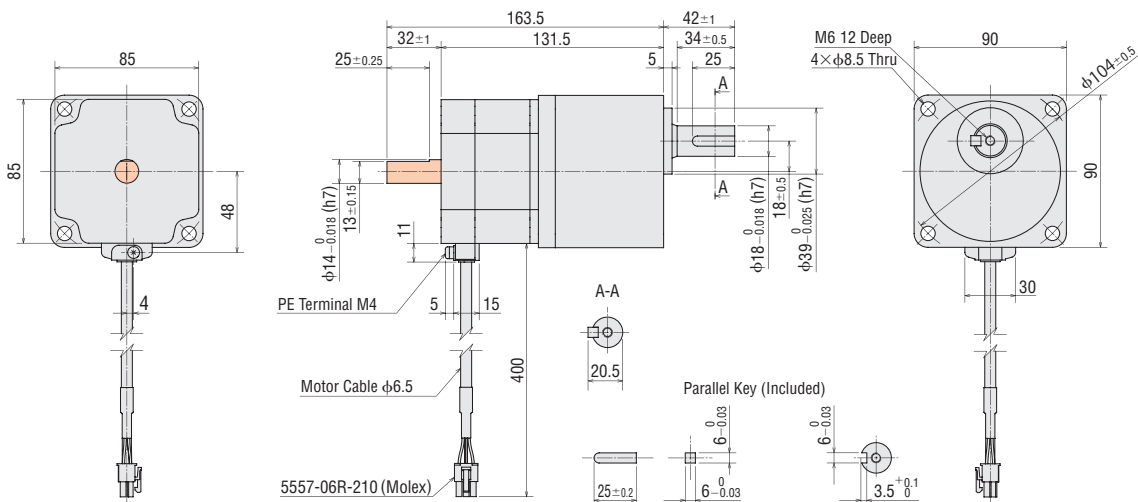

● Either **A** (Single-Phase 100-120 VAC) or **C** (Single-Phase 200-240 VAC) indicating the configuration is entered where is located within the product name.

● A value indicating the Gear Ratio is entered where the box is located within the product name.

● A number indicating the desired length of **1** (1 m), **2** (2 m) or **3** (3 m) for the cable included with the product is entered where the box is located within the product name.

● These dimensions are for double shaft models. For single shaft models, ignore the areas.

◇ **TS Geared Type with Electromagnetic Brake**

Frame Size 42 mm

Product Name		Motor Product Name	Gear Ratio	Mass kg
Pulse Input	Built-In Controller			
RKS543M D-TS □ ◇	RKS543M TS □ ◇	PKE543MC-TS □	3.6, 7.2, 10, 20, 30	0.55

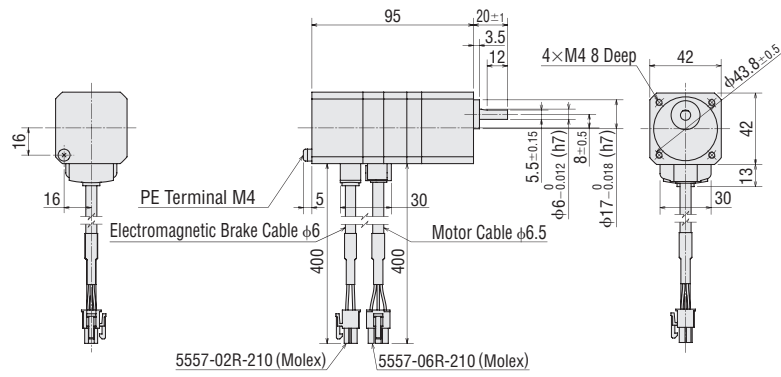

Frame Size 60 mm

Product Name		Motor Product Name	Gear Ratio	Mass kg
Pulse Input	Built-In Controller			
RKS564M D-TS □ ◇	RKS564M TS □ ◇	PKE564MC-TS □	3.6, 7.2, 10, 20, 30	1.4

● Mounting Screw: M4×60 P0.7 (4 screws are included with the product)

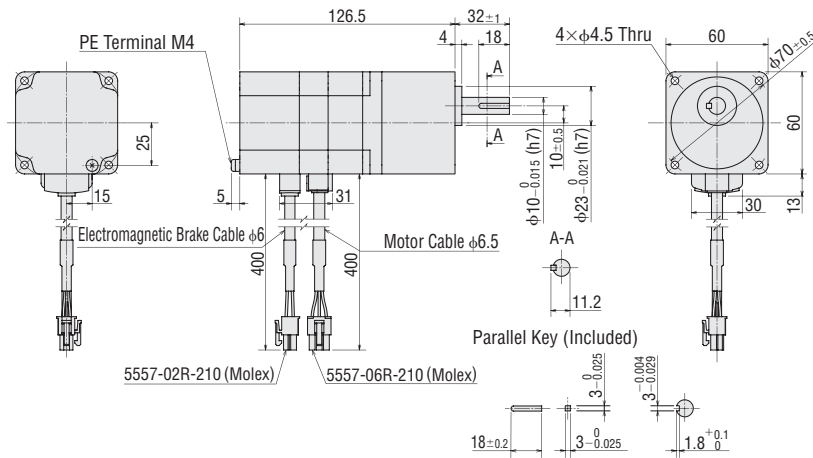

Frame Size 90 mm

Product Name		Motor Product Name	Gear Ratio	Mass kg
Pulse Input	Built-In Controller			
RKS596M D-TS □ ◇	RKS596M TS □ ◇	PKE596MC-TS □	3.6, 7.2, 10, 20, 30	3.9

● Mounting Screw: M8×90 P1.25 (4 screws are included with the product)

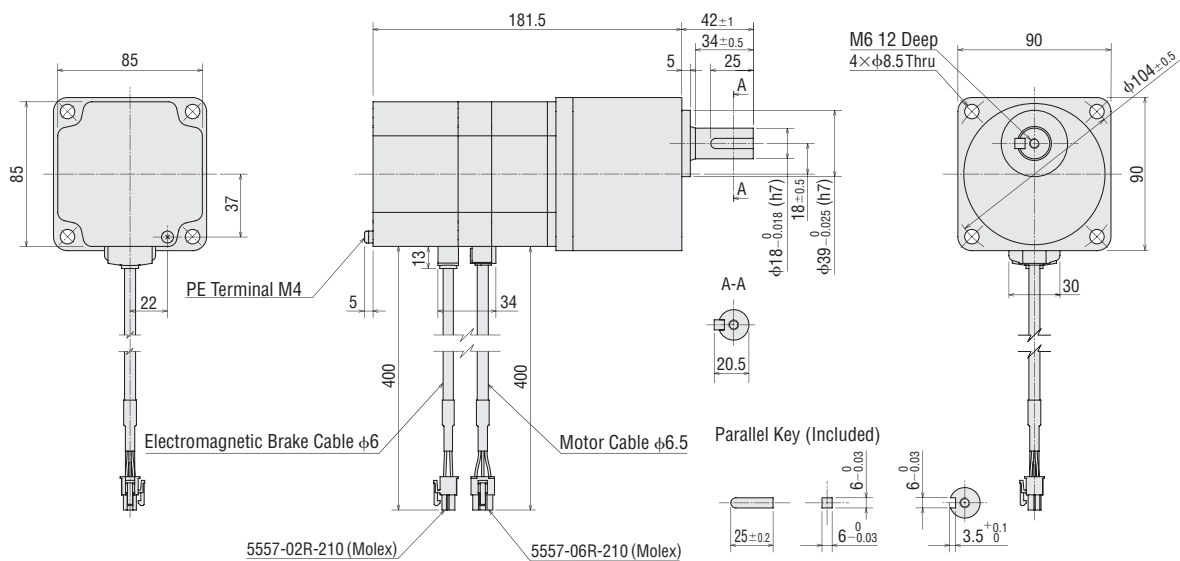

- Either **A** (Single-Phase 100-120 VAC) or **C** (Single-Phase 200-240 VAC) indicating the configuration is entered where □ is located within the product name.
- A value indicating the Gear Ratio is entered where the box □ is located within the product name.
- A number indicating the desired length of **1** (1 m), **2** (2 m) or **3** (3 m) for the cable included with the product is entered where the box ◇ is located within the product name.

◇ PS Geared Type

Frame Size 42 mm

Product Name		Motor Product Name	Gear Ratio	L1	L2	Mass kg
Built-In Controller	Pulse Input					
RKS545A	D-PS	PKE545AC-PS	5, 7.2, 10	73.5	-	0.58
RKS545B	D-PS	PKE545BC-PS				
RKS543A	D-PS	PKE543AC-PS	25, 36, 50	86	-	0.61
RKS543B	D-PS	PKE543BC-PS				

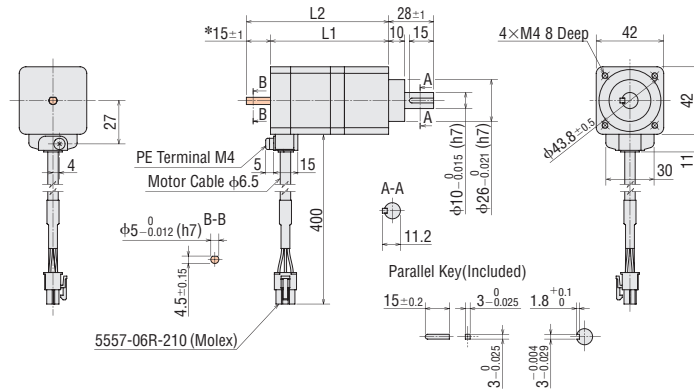

* Length of milling cut for double shaft type is 15±0.25.

Frame Size 60 mm

Product Name		Motor Product Name	Gear Ratio	L1	L2	Mass kg
Built-In Controller	Pulse Input					
RKS566A	D-PS	PKE566AC-PS	5, 7.2, 10	92	-	1.3
RKS566B	D-PS	PKE566BC-PS				
RKS564A	D-PS	PKE564AC-PS	25, 36, 50	101.5	-	1.4
RKS564B	D-PS	PKE564BC-PS				

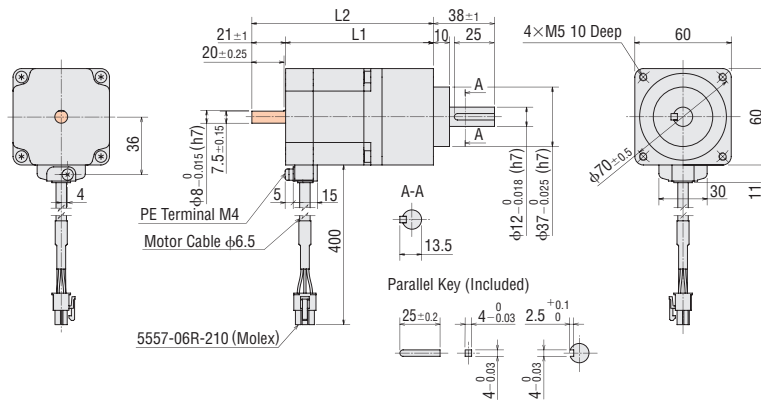

Frame Size 90 mm

Product Name		Motor Product Name	Gear Ratio	L1	L2	Mass kg
Built-In Controller	Pulse Input					
RKS599A	D-PS	PKE599AC-PS	5, 7.2, 10	145	-	4.4
RKS599B	D-PS	PKE599BC-PS				
RKS596A	D-PS	PKE596AC-PS	25, 36, 50	142.5	-	4.1
RKS596B	D-PS	PKE596BC-PS				

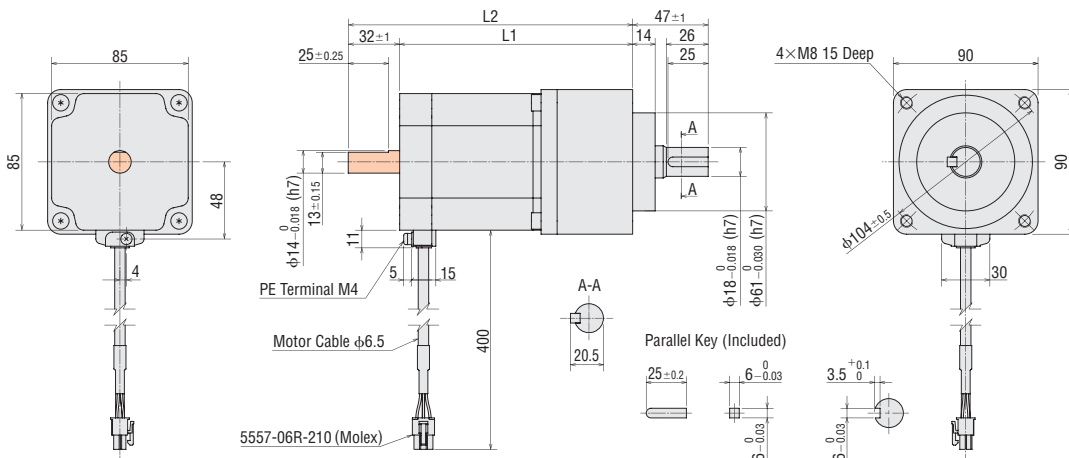

- Either **A** (Single-Phase 100-120 VAC) or **C** (Single-Phase 200-240 VAC) indicating the configuration is entered where is located within the product name.
- A value indicating the Gear Ratio is entered where the box is located within the product name.
- A number indicating the desired length of **1** (1 m), **2** (2 m) or **3** (3 m) for the cable included with the product is entered where the box is located within the product name.
- These dimensions are for double shaft models. For single shaft models, ignore the areas.

◆ PS Geared Type with Electromagnetic Brake

Frame Size 42 mm

Product Name		Motor Product Name	Gear Ratio	L	Mass kg
Built-In Controller	Pulse Input				
RKS545M <input type="checkbox"/> D-PS <input type="checkbox"/> ◆	RKS545M <input type="checkbox"/> -PS <input type="checkbox"/> ◆	PKE545MC-PS <input type="checkbox"/>	5, 7.2, 10	103	0.72
RKS543M <input type="checkbox"/> D-PS <input type="checkbox"/> ◆	RKS543M <input type="checkbox"/> -PS <input type="checkbox"/> ◆	PKE543MC-PS <input type="checkbox"/>	25, 36, 50	115.5	0.75

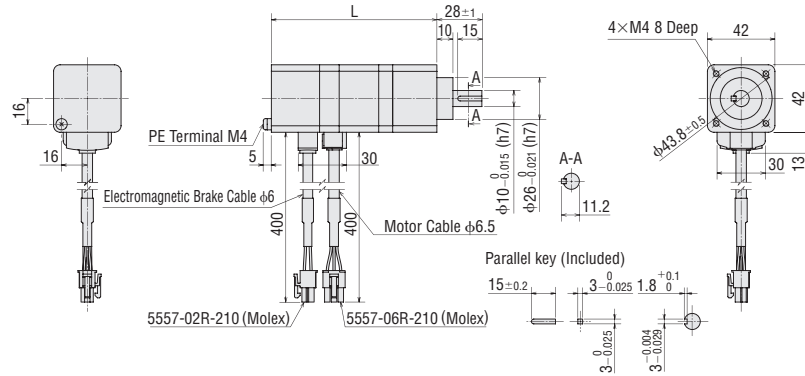

Frame Size 60 mm

Product Name		Motor Product Name	Gear Ratio	L	Mass kg
Built-In Controller	Pulse Input				
RKS566M <input type="checkbox"/> D-PS <input type="checkbox"/> ◆	RKS566M <input type="checkbox"/> -PS <input type="checkbox"/> ◆	PKE566MC-PS <input type="checkbox"/>	5, 7.2, 10	127	1.6
RKS564M <input type="checkbox"/> D-PS <input type="checkbox"/> ◆	RKS564M <input type="checkbox"/> -PS <input type="checkbox"/> ◆	PKE564MC-PS <input type="checkbox"/>	25, 36, 50	136	1.7

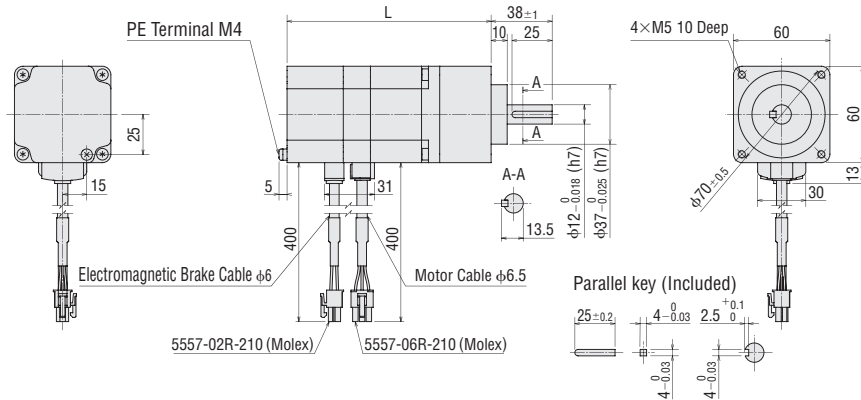

Frame Size 90 mm

Product Name		Motor Product Name	Gear Ratio	L	Mass kg
Built-In Controller	Pulse Input				
RKS599M <input type="checkbox"/> D-PS <input type="checkbox"/> ◆	RKS599M <input type="checkbox"/> -PS <input type="checkbox"/> ◆	PKE599MC-PS <input type="checkbox"/>	5, 7.2, 10	195	5.2
RKS596M <input type="checkbox"/> D-PS <input type="checkbox"/> ◆	RKS596M <input type="checkbox"/> -PS <input type="checkbox"/> ◆	PKE596MC-PS <input type="checkbox"/>	25, 36, 50	192	4.9

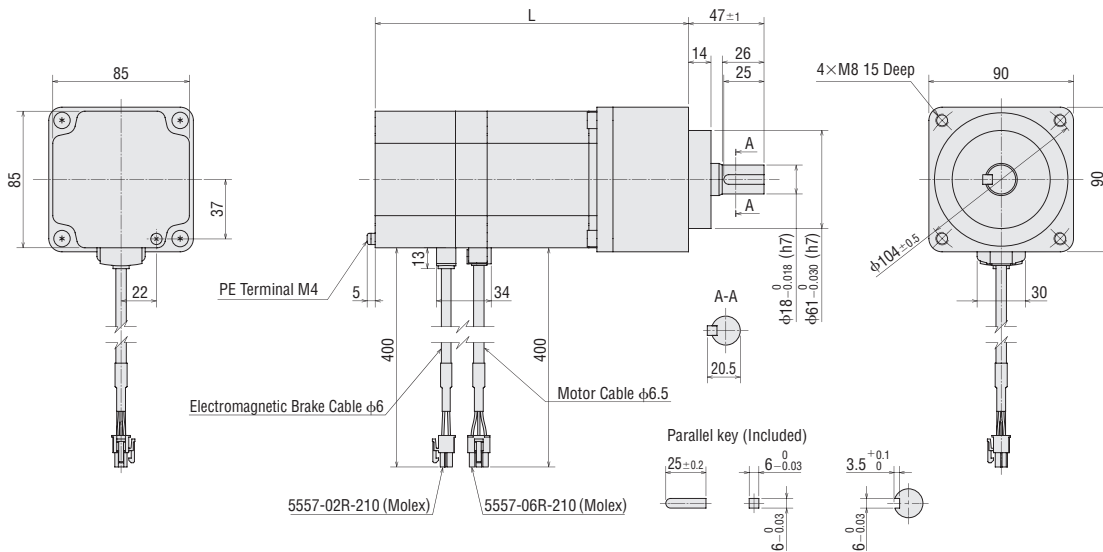

- Either **A** (Single-Phase 100-120 VAC) or **C** (Single-Phase 200-240 VAC) indicating the configuration is entered where is located within the product name.
- A value indicating the Gear Ratio is entered where the box is located within the product name.
- A number indicating the desired length of **1** (1 m), **2** (2 m) or **3** (3 m) for the cable included with the product is entered where the box is located within the product name.

◇ Harmonic Geared Type

Frame Size 42 mm

Product Name		Motor Product Name	Gear Ratio	Mass kg
Built-in Controller	Pulse Input			
RKS543A D -HS ◇	RKS543A HS ◇	PKE543AC-HS ◇	50, 100	0.47
RKS543B D -HS ◇	RKS543B HS ◇	PKE543BC-HS ◇		

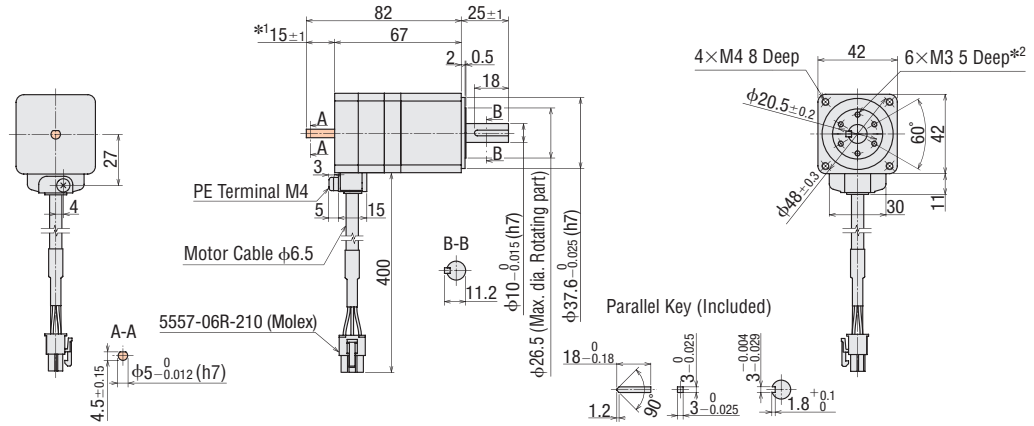

*1 Length of milling cut for double shaft type is 15±0.25.

*2 The position of the output shaft relative to the screw holes on the rotating part is arbitrary.

Frame Size 60 mm

Product Name		Motor Product Name	Gear Ratio	Mass kg
Built-in Controller	Pulse Input			
RKS564A D -HS ◇	RKS564A HS ◇	PKE564AC-HS ◇	50, 100	1.2
RKS564B D -HS ◇	RKS564B HS ◇	PKE564BC-HS ◇		

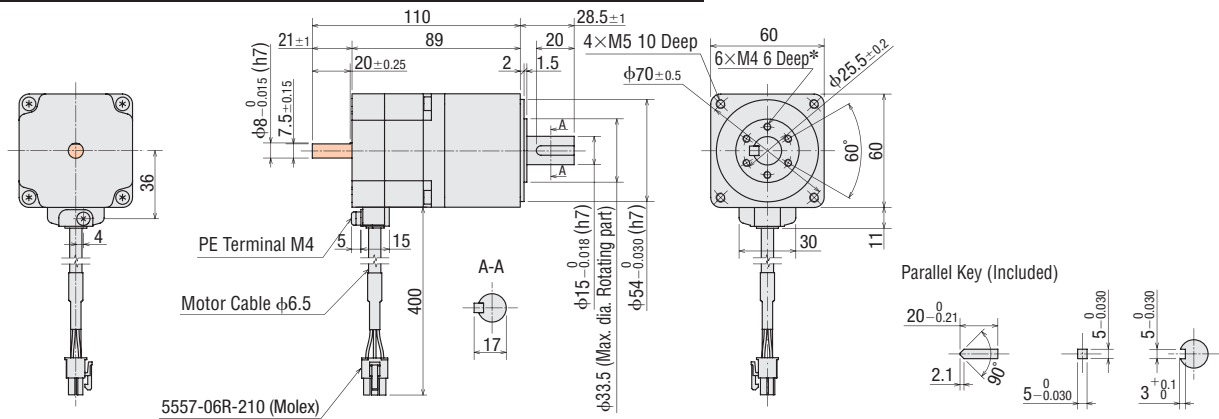

* The position of the output shaft relative to the screw holes on the rotating part is arbitrary.

Frame Size 90 mm

Product Name		Motor Product Name	Gear Ratio	Mass kg
Built-in Controller	Pulse Input			
RKS596A D -HS ◇	RKS596A HS ◇	PKE596AC-HS ◇	50, 100	3.9
RKS596B D -HS ◇	RKS596B HS ◇	PKE596BC-HS ◇		

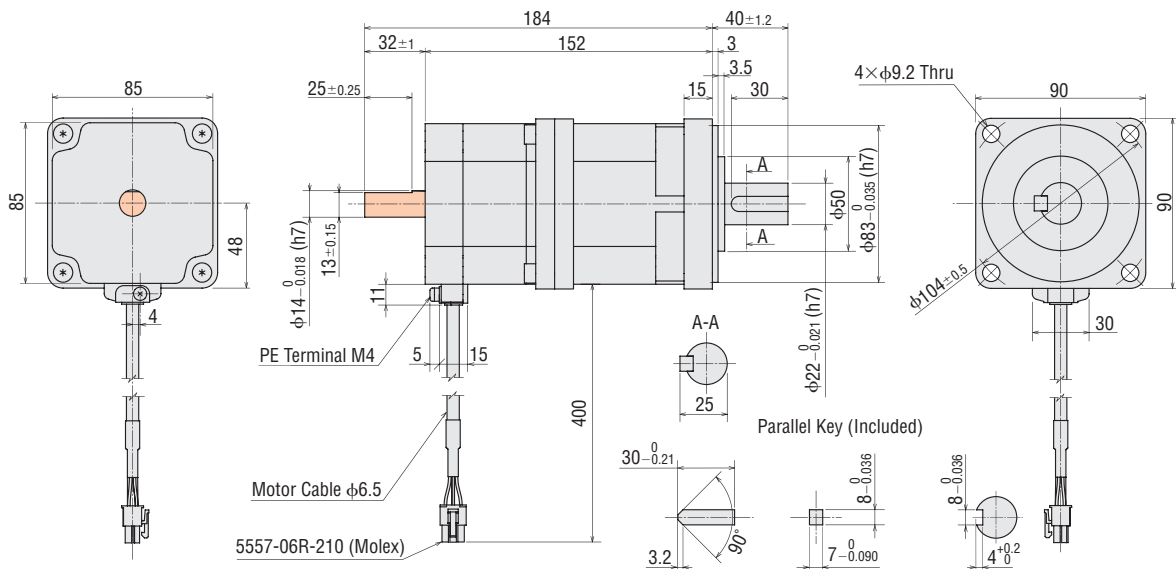

- Either **A** (Single-Phase 100-120 VAC) or **C** (Single-Phase 200-240 VAC) indicating the configuration is entered where is located within the product name.
- A value indicating the Gear Ratio is entered where the box is located within the product name.
- A number indicating the desired length of **1** (1 m), **2** (2 m) or **3** (3 m) for the cable included with the product is entered where the box is located within the product name.
- These dimensions are for double shaft models. For single shaft models, ignore the areas.

◇ Harmonic Geared Type with Electromagnetic Brake

Frame Size 42 mm

Product Name		Motor Product Name	Gear Ratio	Mass kg
Built-In Controller	Pulse Input			
RKS543M D-HS <input type="checkbox"/> <input type="checkbox"/> ◇	RKS543M -HS <input type="checkbox"/> <input type="checkbox"/> ◇	PKE543MC-HS <input type="checkbox"/>	50, 100	0.61

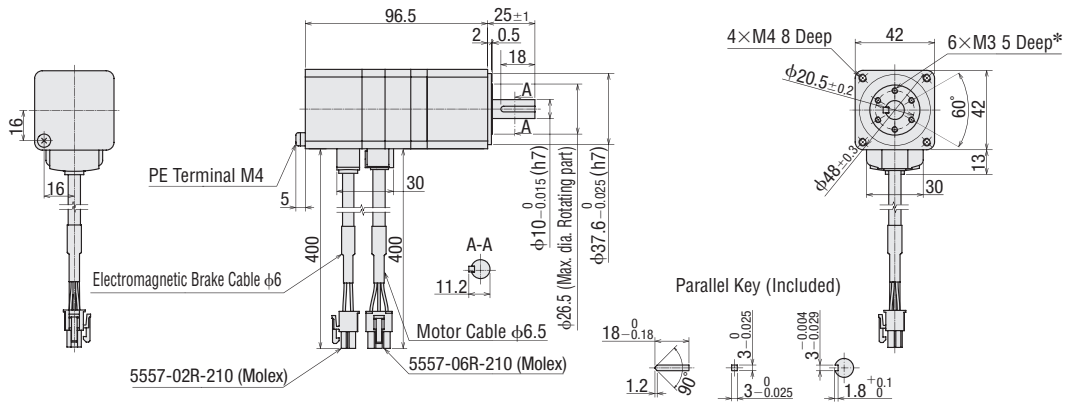

* The position of the output shaft relative to the screw holes on the rotating part is arbitrary.

Frame Size 60 mm

Product Name		Motor Product Name	Gear Ratio	Mass kg
Built-In Controller	Pulse Input			
RKS564M D-HS <input type="checkbox"/> <input type="checkbox"/> ◇	RKS564M -HS <input type="checkbox"/> <input type="checkbox"/> ◇	PKE564MC-HS <input type="checkbox"/>	50, 100	1.5

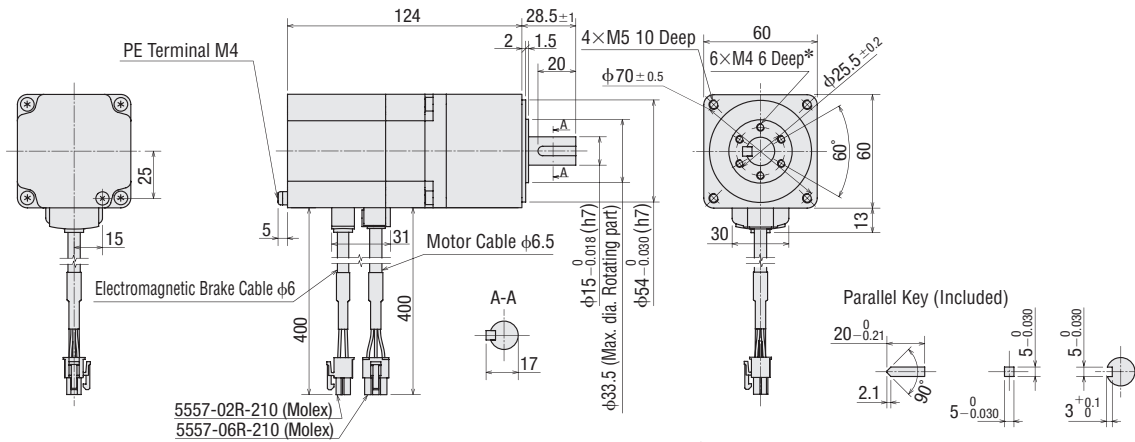

* The position of the output shaft relative to the screw holes on the rotating part is arbitrary.

Frame Size 90 mm

Product Name		Motor Product Name	Gear Ratio	Mass kg
Built-In Controller	Pulse Input			
RKS596M D-HS <input type="checkbox"/> <input type="checkbox"/> ◇	RKS596M -HS <input type="checkbox"/> <input type="checkbox"/> ◇	PKE596MC-HS <input type="checkbox"/>	50, 100	4.8

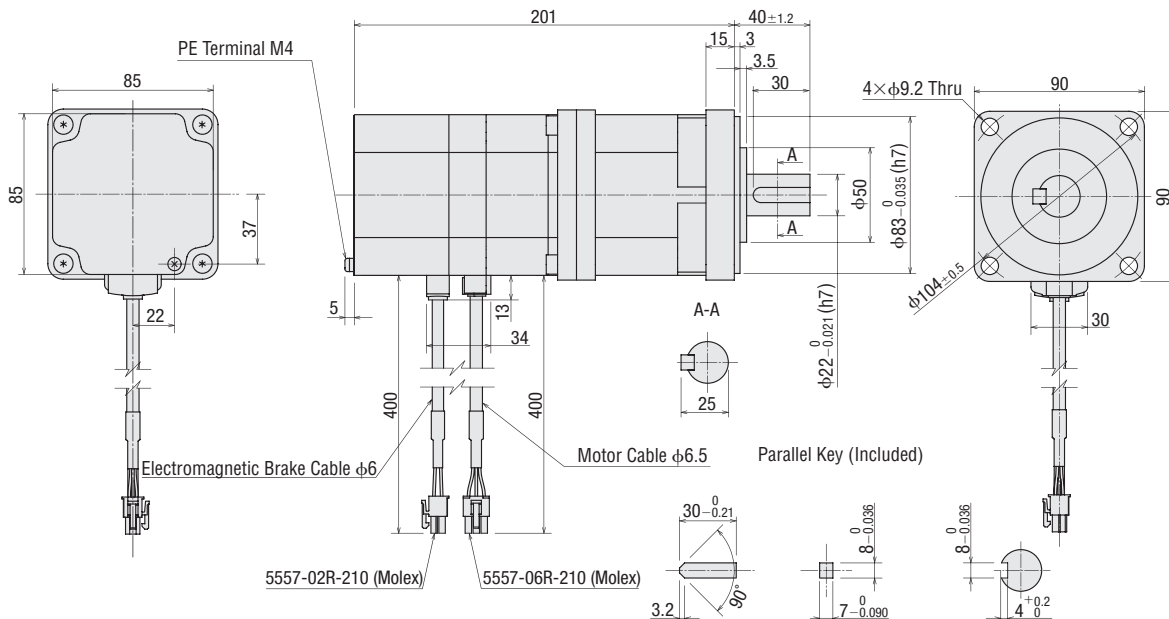

- Either **A** (Single-Phase 100-120 VAC) or **C** (Single-Phase 200-240 VAC) indicating the configuration is entered where is located within the product name.
- A value indicating the Gear Ratio is entered where the box is located within the product name.
- A number indicating the desired length of **1** (1 m), **2** (2 m) or **3** (3 m) for the cable included with the product is entered where the box is located within the product name.

● Cable for Motor (Included), Cable for Electromagnetic Brake (Included), Cable for Encoder (Included)

◇ Only with the type supplied with a connection cable

Common to All Types

● Cable for Motor

Cable Type	Length L (m)
Cable for Motor 1 m	1
Cable for Motor 2 m	2
Cable for Motor 3 m	3

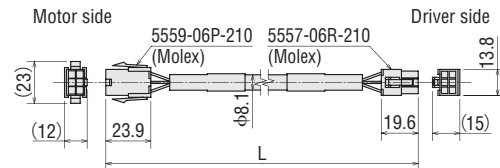

● Cable for Electromagnetic Brake (Only for electromagnetic brake type)

Cable for Motor	Cable Type
Cable for Motor 1 m	1
Cable for Motor 2 m	2
Cable for Motor 3 m	3

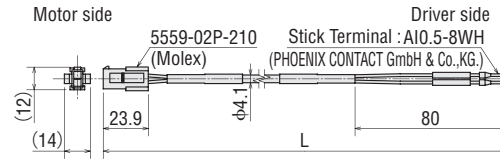

● Cable for Encoder (Only for encoder type)

Cable for Motor	Cable Type
Cable for Motor 1 m	1
Cable for Motor 2 m	2
Cable for Motor 3 m	3

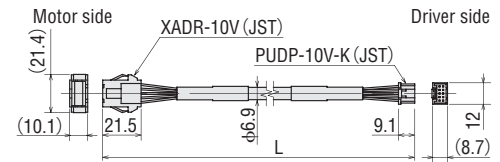

● Drivers

◇ Built-In Controller Type

Mass: 0.8kg

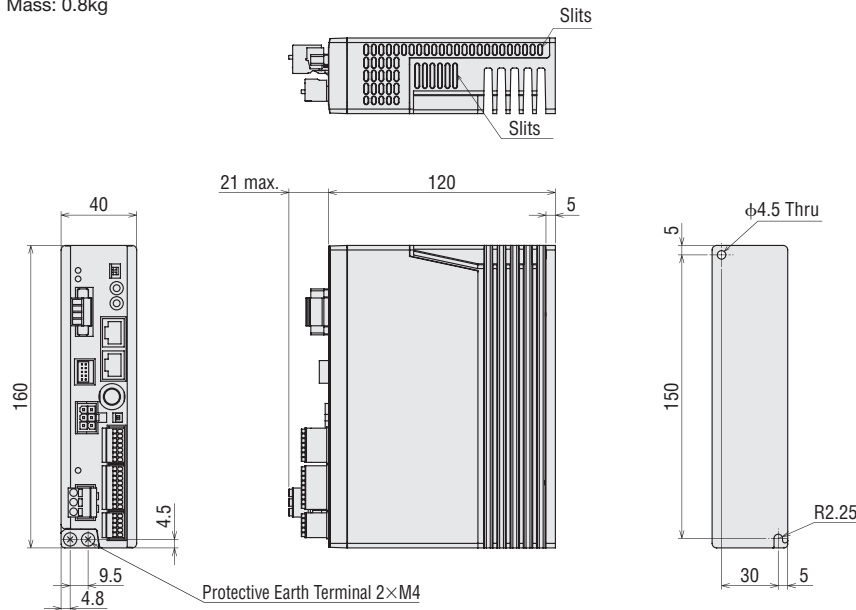

● Accessories

- Connector for Power Input Terminal (CN1)
Connector: MC1,5/4-STF-3,5 (PHOENIX CONTACT GmbH & Co.,KG.)
- Connector for Sensor Signal (CN5)
Connector: FK-MC0,5/5-ST-2,5 (PHOENIX CONTACT GmbH & Co.,KG.)
- Connector for Input Signal (CN8)
Connector: FK-MC0,5/9-ST-2,5 (PHOENIX CONTACT GmbH & Co.,KG.)
- Connector for Output Signal (CN9)
Connector: FK-MC0,5/7-ST-2,5 (PHOENIX CONTACT GmbH & Co.,KG.)
- Connector for Regeneration Unit/Main Power Supply (CN3)
Connector: FKCT2,5/3-ST-5,08 (PHOENIX CONTACT GmbH & Co.,KG.)

◇ Pulse Input Type

Standard Type with Electromagnetic Brake

Mass: 0.8kg

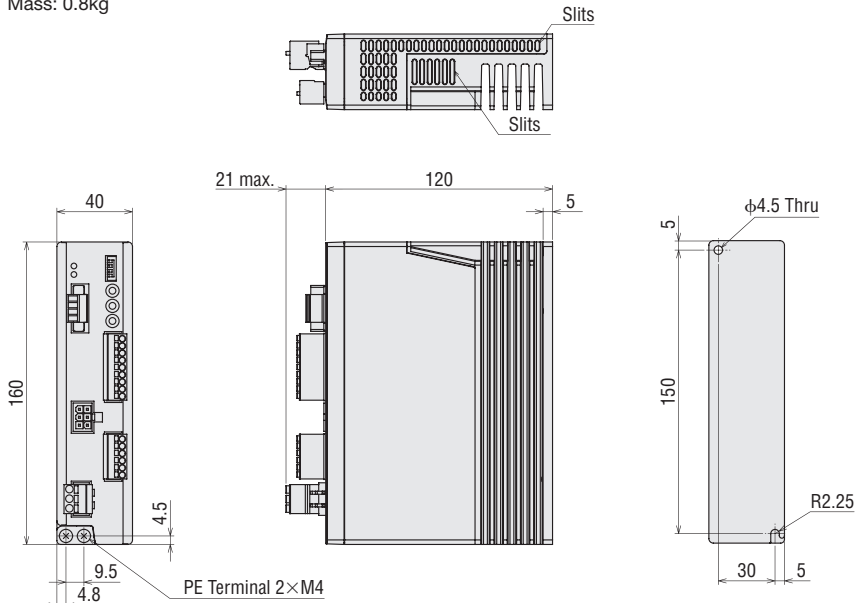

● Included

- I/O Signal Connector (CN5)
Connector:FK-MCP1,5/9-ST-3,81 (PHOENIX CONTACT GmbH & Co.,KG.)
- Pulse Input Connector (CN4)
Connector:FK-MCP1,5/6-ST-3,81 (PHOENIX CONTACT GmbH & Co.,KG.)
- Electromagnetic Brake Connection Terminal Connector (CN1)
Connector:MC1,5/4-STF-3,5 (PHOENIX CONTACT GmbH & Co.,KG.)
- Power Source Input Connector (CN3)
Connector:FKCT2,5/3-ST-5,08 (PHOENIX CONTACT GmbH & Co.,KG.)
- * Electromagnetic brake type only

Standard Type

Mass: 0.8kg

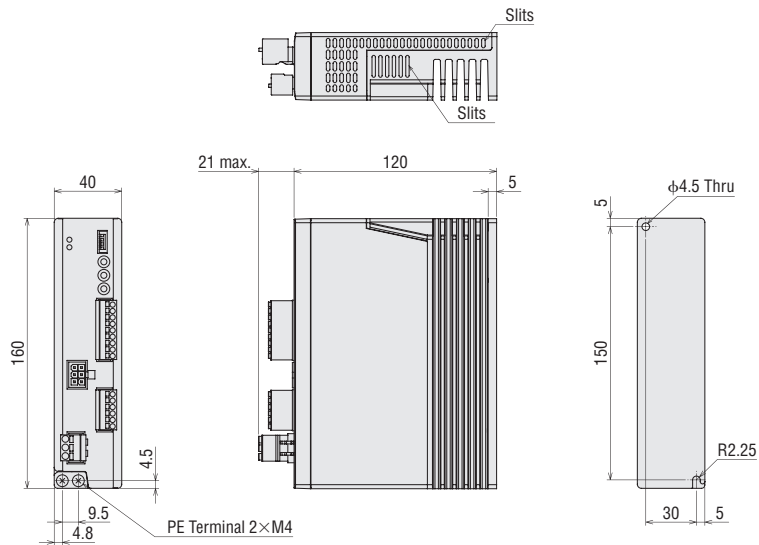

● Included

- I/O Signal Connector (CN5)
Connector:FK-MCP1,5/9-ST-3,81 (PHOENIX CONTACT GmbH & Co.,KG.)
- Pulse Input Connector (CN4)
Connector:FK-MCP1,5/6-ST-3,81 (PHOENIX CONTACT GmbH & Co.,KG.)
- Power Source Input Connector (CN3)
Connector:FKCT2,5/3-ST-5,08 (PHOENIX CONTACT GmbH & Co.,KG.)

Connection and Operation (Built-In Controller Type)

Names and Functions of Driver Parts

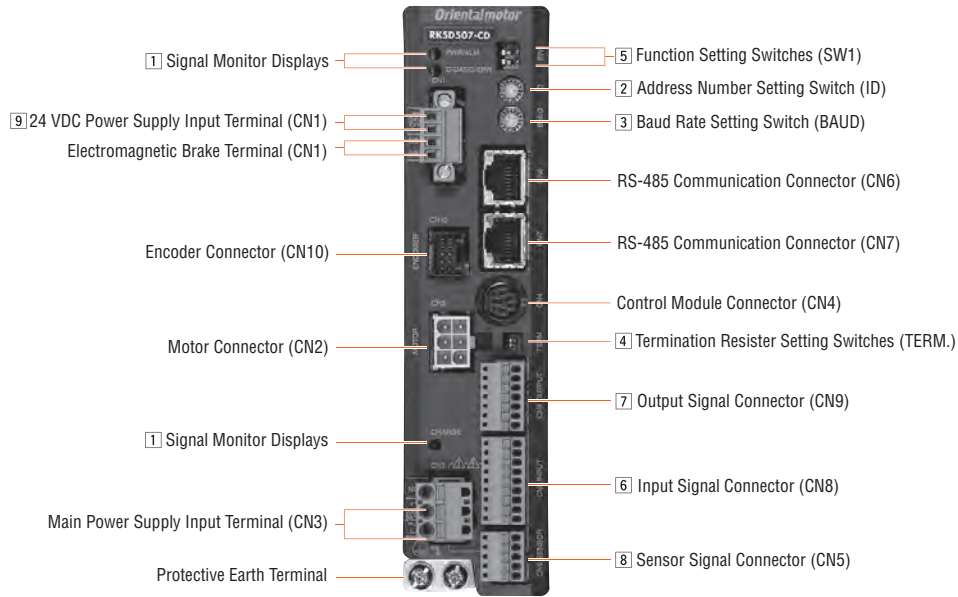

1 Signal Monitor Displays

◇ LED Indicators

Indication	Color	Function	When Activated
PWR	Green	Power Supply Indication	Lights when 24 VDC power is on.
ALM	Red	Alarm Indication	Blinks when protective functions are activated.
C-DAT	Green	Communication Indication	Lights when communication data is received or sent.
C-ERR	Red	Communication Error Indication	Lights when there is an error with communication data.
CHARGE	Red	Power On Indication	Lights when main power is supplied.

2 Address Number Setting Switch (ID)

Indication	Switch Name	Function
ID	Address Number Setting Switch	Set the address number for RS-485 communication (Factory Setting: 0).

3 Baud Rate Setting Switch (BAUD)

Indication	Switch Name	Function
BAUD	Baud Rate Setting Switch	Set the baud rate for RS-485 communications (Factory Setting: 7).

◇ Setting the Baud Rate for RS-485 Communications

No.	Baud Rate (bps)
0	9600
1	19200
2	38400
3	57600
4	115200
5~6	Not used
7	625000 (Connect to Network Converter)
8~F	Not used

④ Termination Resistor Setting Switches (TERM.)

Indication	No.	Function
TERM.	1	Set the termination resistor (120 Ω) for RS-485 communication (Factory setting: OFF).
	2	OFF : No termination resistor ON : Set the termination resistor

* Please use the same settings for both No. 1 and No. 2.

⑤ Function Setting Switches (SW1)

Indication	No.	Function
SW1	1	Set the address number in combination with the address number setting switch (ID) (Factory setting: OFF).
	2	Set the protocol for RS-485 communication (Factory setting: OFF).

◇ RS-485 Communication Protocol Setting

Destination No.	Connect to Network convertor	Modbus RTU Mode
2	OFF	ON

⑥ Input Signal Connector (CN8)

Indication	Pin No.	Signal Name	Initial Value
CN8	1	IN0	HOME Perform the return-to-home operation.
	2	IN1	START Perform the positioning operation.
	3	IN2	M0
	4	IN3	M1
	5	IN4	M2
	6	IN5	FREE Stop motor excitation and release the electromagnetic brake.
	7	IN6	STOP Stop the motor.
	8	IN7	ALM-RST Reset the current alarm.
	9	IN-COM1	Input signal common

* Assigned functions are set by means of the parameter settings. The above is the initial value. For details, refer to the User's Manual.

The following input signals can be assigned to input terminals IN0~7.

Input Signal									
0 : Not used	5: SSTART	10: MS2	17: AWO	32: R0	37: R5	42: R10	47: R15	52: M4	
1: FWD	6: +JOG	11: MS3	18: STOP	33: R1	38: R6	43: R11	48: M0	53: M5	
2: RVS	7: -JOG	12: MS4	24: ALM-RST	34: R2	39: R7	44: R12	49: M1		
3: HOME	8: MS0	13: MS5	25: P-PRESET	35: R3	40: R8	45: R13	50: M2		
4: START	9: MS1	16: FREE	27: HMI	36: R4	41: R9	46: R14	51: M3		

⑦ Output Signal Connector (CN9)

Indication	Pin No.	Signal Name	Initial Value
CN9	1	OUT0	HOME-P Output when the motor is home.
	2	OUT1	MOVE Output while the motor is under operation.
	3	OUT2	AREA1 Output when the motor is in area 1.
	4	OUT3	READY Output when driver operation preparations have finished.
	5	OUT4	WNG The driver's warning status is output.
	6	OUT5	ALM The driver's alarm status is output (Point B).
	7	OUT-COM	Output signal common

* Assigned functions are set by means of the parameter settings. The above is the initial value. For details, refer to the User's Manual.

The following output signals can be assigned to output terminals OUT0~5.

Input Signal									
0: Not used	7: -JOG_R	16: FREE_R	36: R4	43: R11	50: M2_R	63: SLIT_R	73: AREA1	85: ZSG	
1: FWD_R	8: MS0_R	17: AWO_R	37: R5	44: R12	51: M3_R	65: ALM	74: AREA2	86: MBC	
2: RVS_R	9: MS1_R	18: STOP_R	38: R6	45: R13	52: M4_R	66: WNG	75: AREA3		
3: HOME_R	10: MS2_R	32: R0	39: R7	46: R14	53: M5_R	67: READY	80: S-BSY		
4: START_R	11: MS3_R	33: R1	40: R8	47: R15	60: +LS_R	68: MOVE	82: MPS		
5: SSTART_R	12: MS4_R	34: R2	41: R9	48: M0_R	61: -LS_R	70: HOME-P	83: STEPOUT		
6: +JOG_R	13: MS5_R	35: R3	42: R10	49: M1_R	62: HOMES_R	72: TIM	84: OH		

⑧ Sensor Signal Connector (CN5)

Indication	Pin No.	Signal Name	Initial Value
CN5	1	+LS	+Side Limit Sensor Input
	2	-LS	-Side Limit Sensor Input
	3	HOMES	Mechanical Home Sensor Input
	4	SLIT	Slit Sensor Input
	5	IN-COM2	Common for Sensor

⑨ 24 VDC Power Input Terminal/Electromagnetic Brake Connection Terminal (CN1)

Indication	I/O	Terminal Name	Content
24V+	Input	24 VDC Power Input Terminal+	The power supply for the driver's control circuit terminal. Always connect while operating.
24V-		24 VDC Power Input Terminal-	
MB1	Output	Electromagnetic Brake Connection Terminal- (Black)	Connect with the electromagnetic brake line of an electromagnetic brake type motor.
MB2		Electromagnetic Brake Connection Terminal+ (White)	

● Connection Diagram
 ◇ Connection to Peripheral Equipment

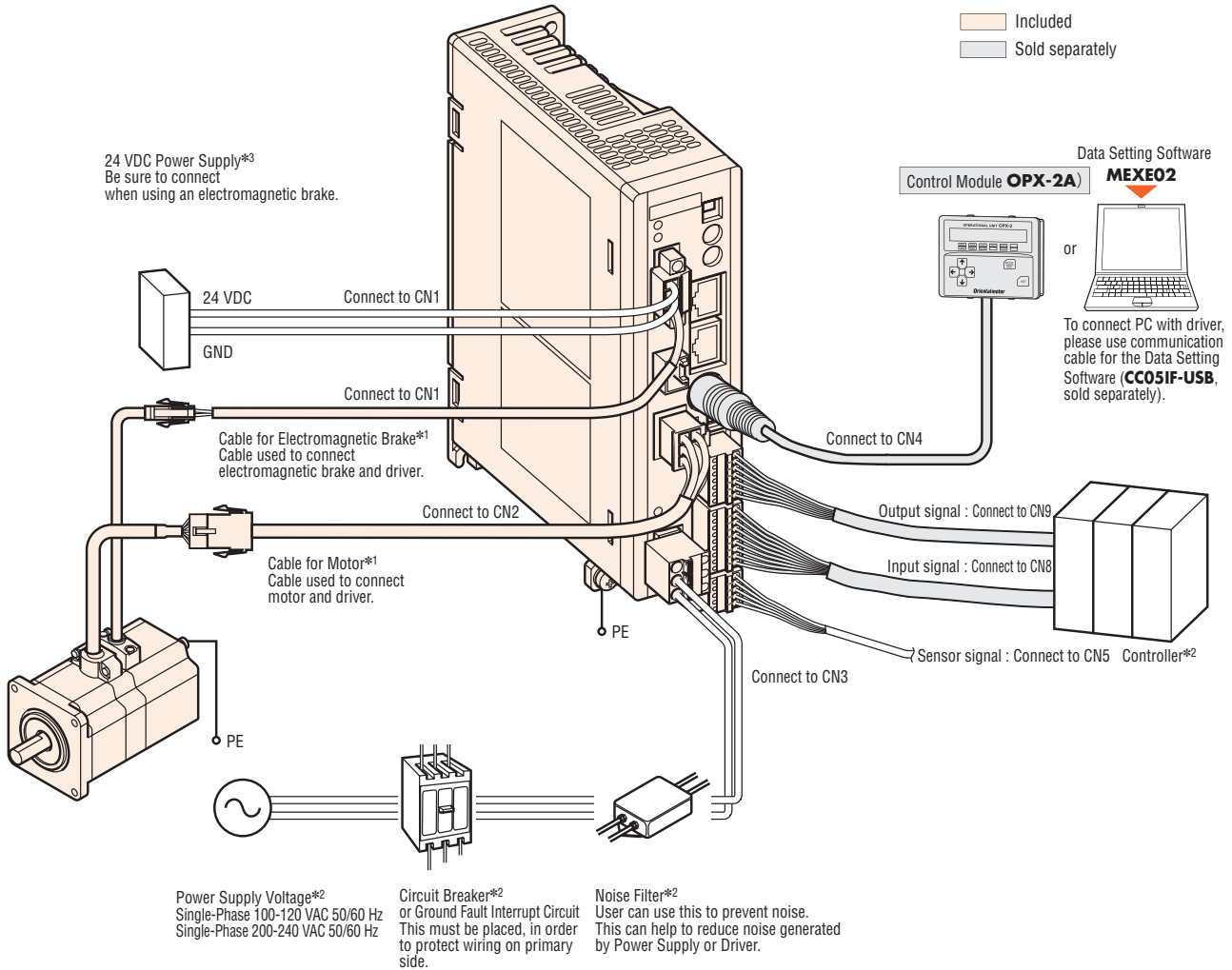

*1 The user can choose from Package with Cable (1 m, 2 m or 3 m) or Package without Cable.
 If the user needs a cable longer than 3 m or a flexible cable, please select an appropriate cable from the accessories (sold separately).
 Keep the wiring distance between the motor and driver to 20 m max.

*2 Not Supplied.

*3 Not Supplied. If the wiring distance between the motor and driver is extended to 15 m or longer by using an accessory cable (sold separately), the 24 VDC±4% specification applies.

◇ Connecting to a Host Controller

● Connecting to a Current Sink Output Circuit

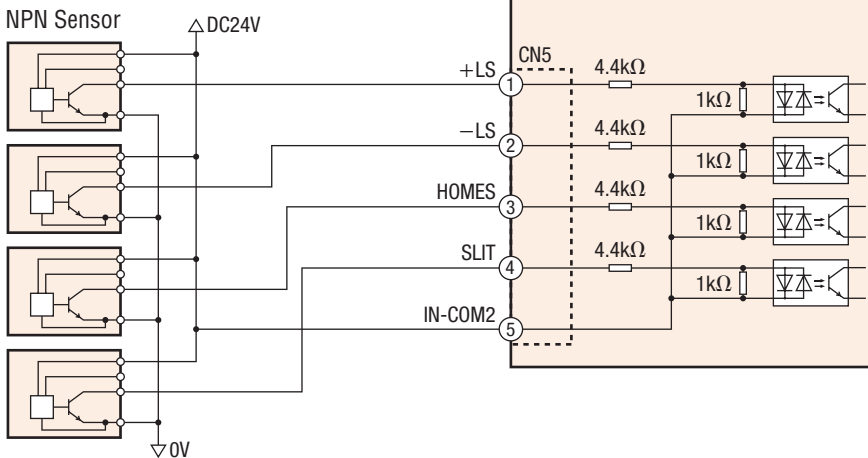
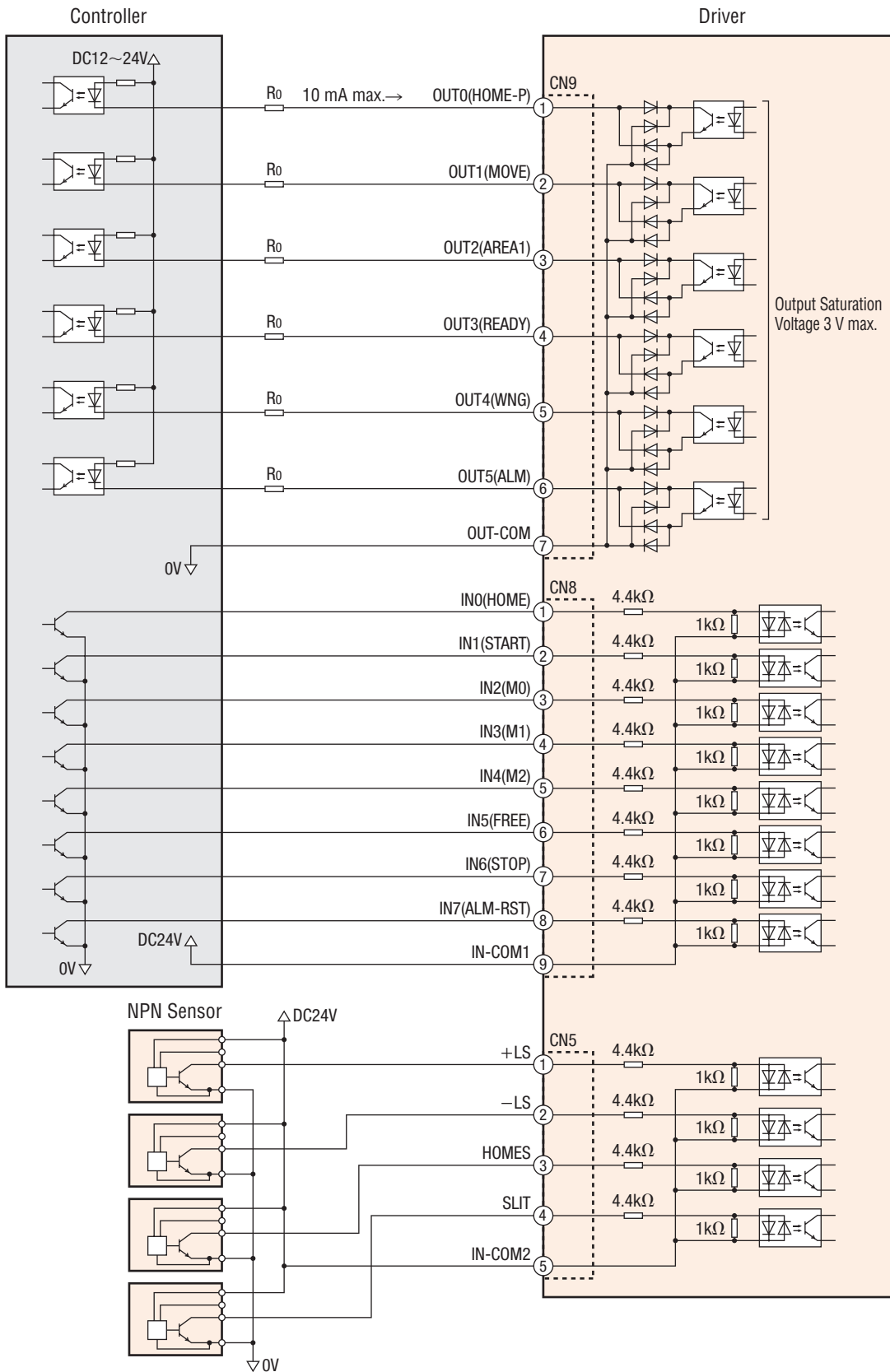

Note

- Use input signals at 24 VDC.
- Use output signals at 12~24 VDC/10 mA or less. If the current exceeds 10 mA, connect an external resistor R_o to adjust current value to less than 10 mA.
- The saturation voltage of the output signal is 3 VDC max.
- Provide a minimum distance of 100 mm between the signal lines and power lines (Power supply lines, motor lines).
Do not run the signal lines in the same duct as power lines nor bundle them with power lines.
- If noise generated by the motor cable or power supply cable causes a problem with the specific wiring or layout, attach shield the cable or ferrite core.

◇ Connecting to a Host Controller

- Connecting to a Current Source Output Circuit

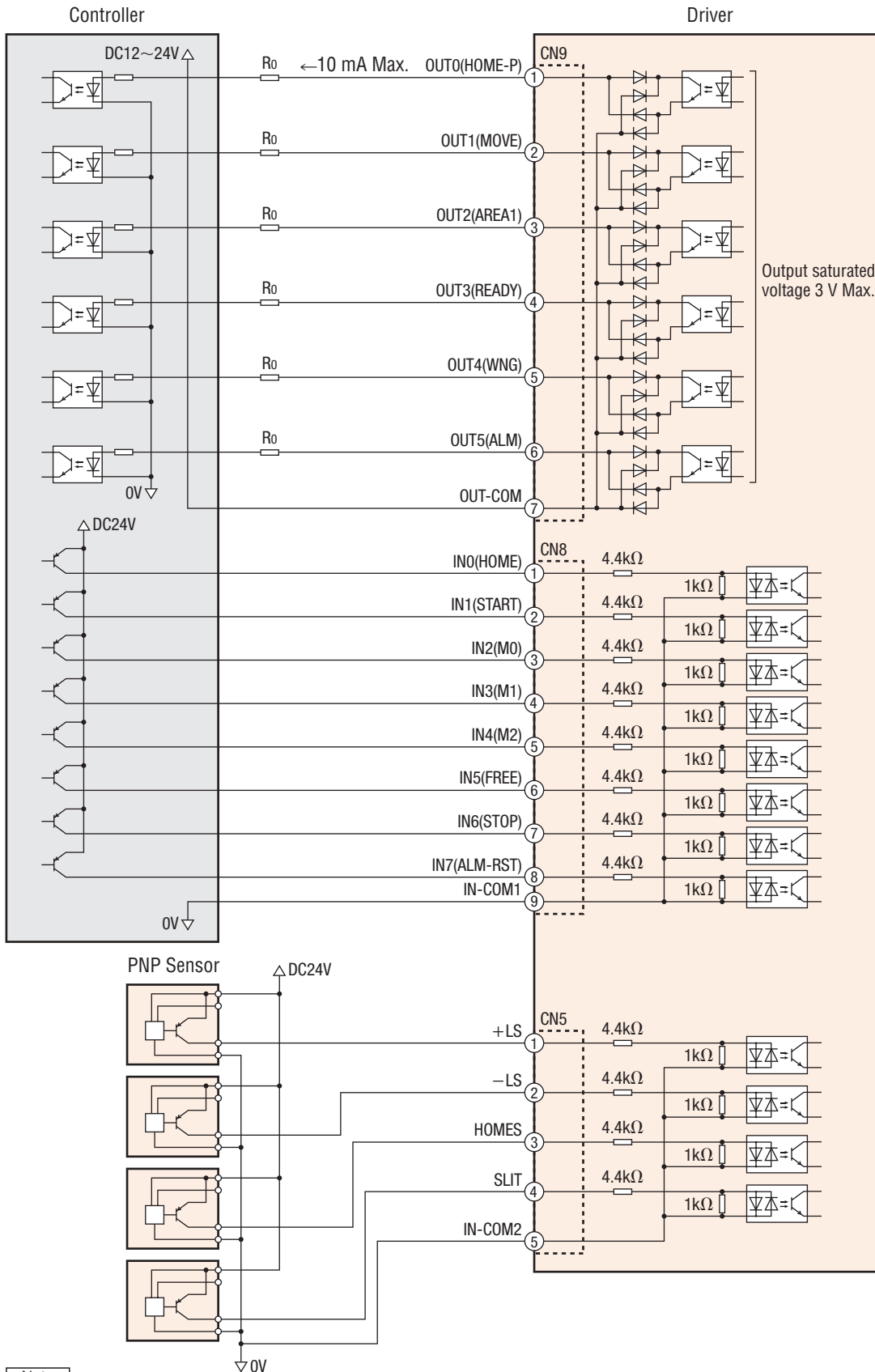

Note

- Use 24 VDC for the input signal.
- Use 12-24 VDC or less for the output signal, and 10 mA or less for the current. If the current exceeds 10 mA, connect an external resistor R_o to reduce the current to less than 10 mA.
- Output saturated voltage should be less than 3 V.
- Signal lines should be kept at least 100 mm away from power lines (power supply lines and motor lines). Do not run the signal lines in the same duct or bundle them together.
- If noise generated by the motor cables or power supply cables causes a problem, try shielding the cables or using ferrite cores.

Connection and Operation (Pulse Input Type)

Names and Functions of Driver Parts

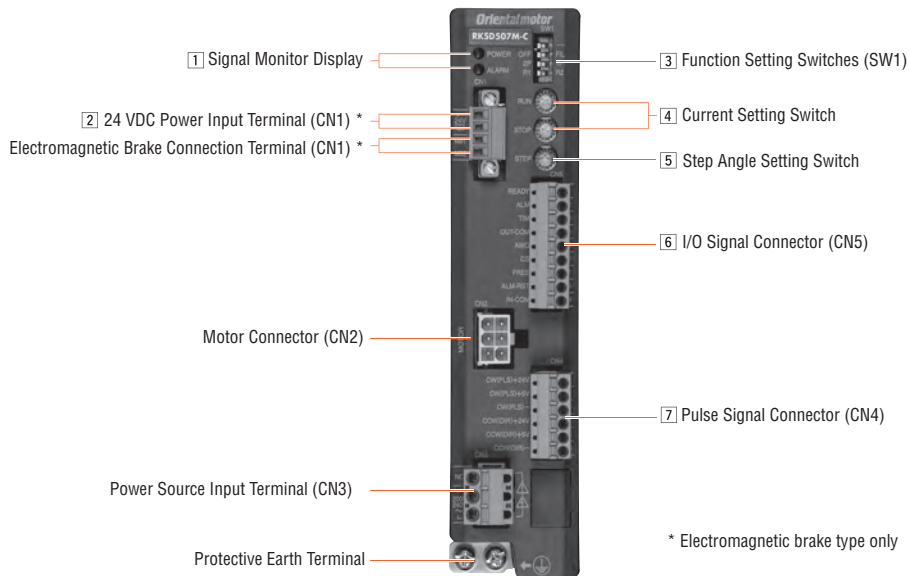

1 Signal Monitor Display

◇ LED Indicator

Indication	Color	Function	Lighting Condition
POWER	Green	Power Supply Indication	When the main power supply is input
ALARM	Red	Alarm Indication	When protective functions are activated (Blink).

◇ Alarm Contents

Blink Count	Function	Operating Condition	ALM-RST Release by Input	Motor Excitation
2	Main circuit overheating	The internal temperature of the driver exceeds 85°C.	Yes	No holding
3	Overvoltage	The internal voltage of the driver exceeds the permissible value	No	
4	Command pulse abnormality	The value of the command pulse becomes abnormal	Yes	
5	Overcurrent	The motor, cable and driver out put circuit shorted out	No	
6	Undervoltage	Power supply is instantaneously shut down Undervoltage	Yes	
7	Automatic control of electromagnetic brake abnormality	24 VDC power supply is not connected The electromagnetic brake is not connected The electromagnetic brake is mis-wired		
9	Electrolytic capacitor abnormality	The electrolytic capacitor of the main circuit is damaged.	No	
	EEPROM abnormality	The saved data of the driver is damaged.		
Lighting	CPU abnormality	CPU malfunctions		

2 24 VDC Power Input Terminals/Electromagnetic Brake Connection Terminals (CN1)

Indication	I/O	Terminal Name	Content
24 V+	Input	24 VDC Input Terminal +	Connects the 24 VDC power for electromagnetic brake.
24 V-	Input	24 VDC Input Terminal -	
MB1	Input	Electromagnetic Brake Connection Terminal- (Black)	Connect the electromagnetic brake wire of the motor with the electromagnetic brake.
MB2	Input	Electromagnetic Brake Connection Terminal+ (White)	

3 Function Setting Switch (SW1)

Indication	No.	Function
R1/R2	1	Sets up the step angle in combination with the step angle setting switch.
2P/1P	2	Switches between 1-pulse input mode and 2-pulse input mode. [2P] for the 2-pulse input mode [1P] for the 1-pulse input mode
OFF/FIL	3	Switches the responsiveness of the motor upon input of pulse.

● Difference in the Motor Responsiveness Depending on the Command Filter (OFF/FIL Switch)

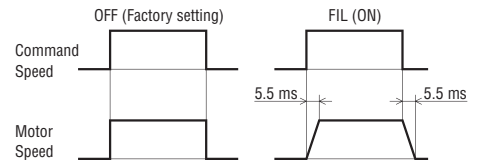

4 Current Setting Switch

Indication	Switch Name	Function
RUN	Operating Current Setting Switch	Sets the motor's operating current. The current value is set by the ratio of rated output current (%).
STOP	Stop Current Setting Switch	Sets the stopped current of the motor. The current value is set by the ratio of rated output current (%).

5 Step Angle Setting Switch

Indication	Function
STEP	Sets up step angle of the motor in combination with the function setting switch (SW1)

Function Setting Switch: R1			
Step Angle Setting Switch (STEP) Scale	Resolution [P/R]	Step Angle [°]	Microsteps/Step
0	500	0.72	1
1	1000	0.36	2
2	1250	0.288	2.5
3	2000	0.18	4
4	2500	0.144	5
5	4000	0.09	8
6	5000	0.072	10
7	10000	0.036	20
8	12500	0.0288	25
9	20000	0.018	40
A	25000	0.0144	50
B	40000	0.009	80
C	50000	0.0072	100
D	62500	0.00576	125
E	100000	0.0036	200
F	125000	0.00288	250

Function Setting Switch: R2			
Step Angle Setting Switch (STEP) Scale	Resolution [P/R]	Step Angle [°]	Microsteps/Step
0	200	1.8	0.4
1	400	0.9	0.8
2	600	0.6	1.2
3	800	0.45	1.6
4	1200	0.3	2.4
5	1600	0.225	3.2
6	3200	0.1125	6.4
7	6000	0.06	12
8	6400	0.05625	12.8
9	7200	0.05	14.4
A	8000	0.045	16
B	12000	0.03	24
C	12800	0.028125	25.6
D	16000	0.0225	32
E	25600	0.0140625	51.2
F	200000	0.0018	400

6 I/O Signal Connector (CN5)

Indication	I/O	Pin Number	Content
READY	Output	1	Outputs when operation of the driver has been prepared.
ALM		2	Output alarm status of the driver (B contact).
TIM		3	Outputs when excitation state of the motor is at step "0" position.
OUT-COM		4	Output common
AW0	Input	5	Stops excitation of the motor.
CS		6	Switches the step angle.
FREE		7	Stops excitation of the motor. With electromagnetic brake type, the electromagnetic brake is also released.
ALM-RST		8	Resets the current alarm.
IN-COM		9	Input common

7 Pulse Signal Connector (CN4)

Indication	Pin Number	Content
CW (PLS) +24 V	1	CW Pulse Input (Pulse Input) [+24 V]
CW (PLS) +5 V	2	CW Pulse Input (Pulse Input) [+5 V or line driver]
CW (PLS) -	3	
CCW (DIR) +24 V	4	CCW Pulse Input (Rotation Direction Input) [+24 V]
CCW (DIR) +5 V	5	CCW Pulse Input (Rotation Direction Input) [+5 V or line driver]
CCW (DIR) -	6	

● Connection Diagram

◇ Connection with Peripheral Equipment

Included in the package.
 Sold separately as Accessories.

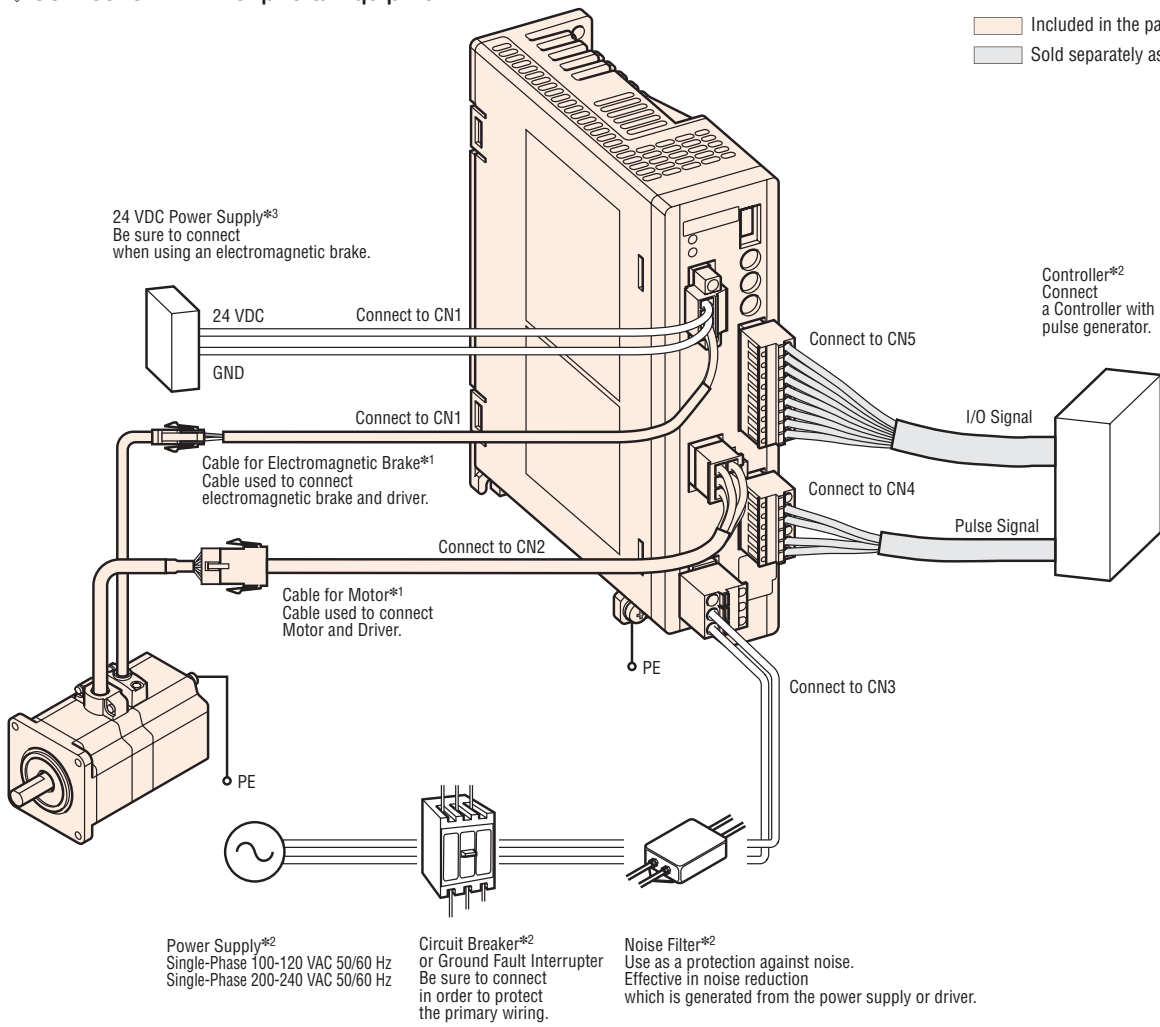

*1 There are 2 types available, one with the cable which connects the motor and driver (1 m, 2 m, 3 m) and the other without any.

If you need cables longer than 3 m or flexible extension cable, select from the accessories (Sold separately).

When wiring the motor and the motor, keep a maximum distance of 20 m.

*2 Not Supplied.

*3 Not Supplied. If the wiring distance between the motor and driver is extended to 15 m or longer by using an accessory cable (Sold separately), the 24 VDC \pm 4% specification applies.

◇ Connection to Programmable Controller

● Connection Diagram for Current Sink Output Circuit

When pulse input is Line Driver

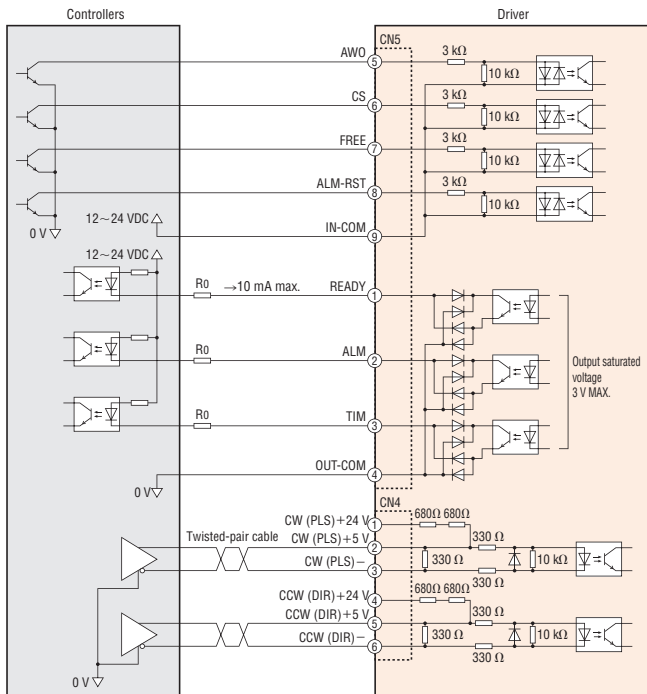

Note

- Use input signal at 12~24 VDC.
- Use output signal at 12~24 VDC 10 mA max. When the current value exceeds 10 mA, connect the external resistor R_0 to keep 10 mA max.
- Output saturated voltage should be less than 3V.
- Provide a minimum distance of 100 mm between the signal lines and power lines (Power supply lines, motor lines).
- Do not run the signal lines in the same duct as power lines or bundle them with power lines.
- If noise generated by the motor cable or power supply cable causes a problem with the specific wiring or layout, shield the cable or use ferrite cores.

● Connecting Diagram for Current Source Output Circuit

When pulse input is Line Driver

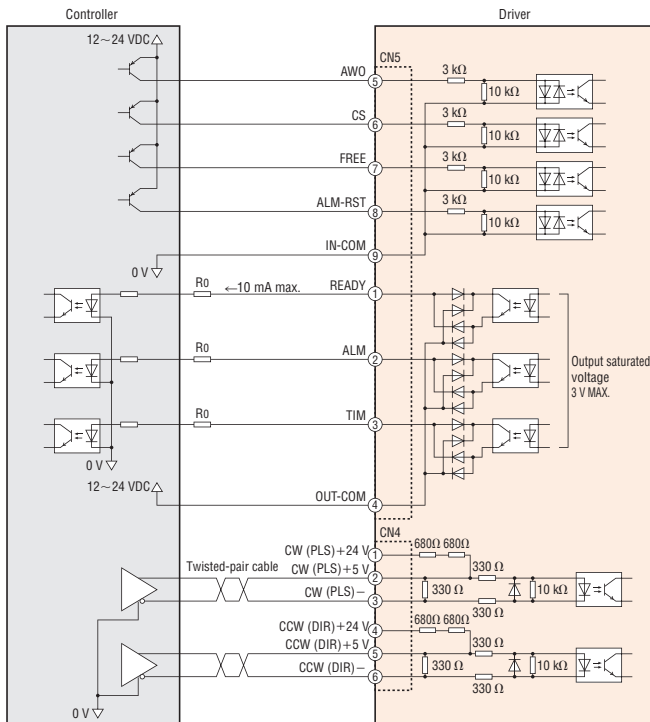

Note

- Use input signal at 12~24 VDC.
- Use output signal at 12~24 VDC 10 mA max. When the current value exceeds 10 mA, connect the external resistor R_0 to keep 10 mA max.
- Output saturated voltage should be less than 3V.
- Provide a minimum distance of 100 mm between the signal lines and power lines (Power supply lines, motor lines).
- Do not run the signal lines in the same duct as power lines or bundle them with power lines.
- If noise generated by the motor cable or power supply cable causes a problem with the specific wiring or layout, shield the cable or use ferrite cores.

When pulse input is of 5 VDC type

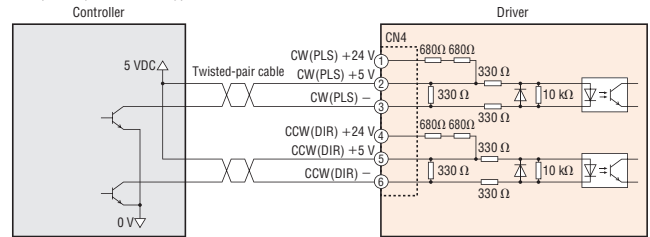

When pulse input is of 24 VDC type

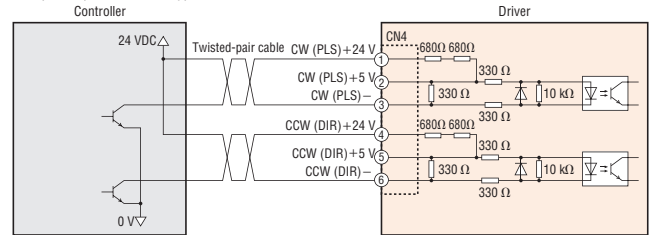

When pulse input is of 5 VDC type

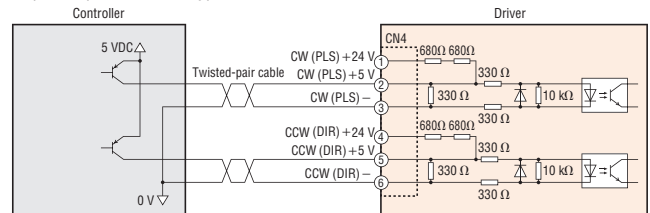

When pulse input is of 24 VDC type

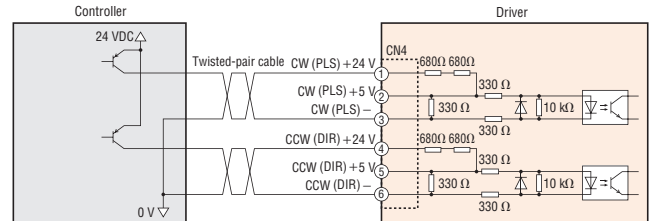

Motor and Driver Combinations

Product names for motor and driver combinations are shown below.

Built-In Controller Type

Type	Product Name	Motor Product Name	Driver Product Name
Standard Type	RKS543 <input type="checkbox"/> D-◇	PKE543 <input type="checkbox"/> C	RKSD503- <input type="checkbox"/> D
	RKS544 <input type="checkbox"/> D-◇	PKE544 <input type="checkbox"/> C	
	RKS545 <input type="checkbox"/> D-◇	PKE545 <input type="checkbox"/> C	
	RKS564 <input type="checkbox"/> D-◇	PKE564 <input type="checkbox"/> C	
	RKS566 <input type="checkbox"/> D-◇	PKE566 <input type="checkbox"/> C	
	RKS569 <input type="checkbox"/> D-◇	PKE569 <input type="checkbox"/> C	
	RKS596 <input type="checkbox"/> D-◇	PKE596 <input type="checkbox"/> C	
	RKS599 <input type="checkbox"/> D-◇	PKE599 <input type="checkbox"/> C	
Standard Type with Electromagnetic Brake	RKS543M <input type="checkbox"/> D-◇	PKE543MC	RKSD503- <input type="checkbox"/> D
	RKS544M <input type="checkbox"/> D-◇	PKE544MC	
	RKS545M <input type="checkbox"/> D-◇	PKE545MC	
	RKS564M <input type="checkbox"/> D-◇	PKE564MC	
	RKS566M <input type="checkbox"/> D-◇	PKE566MC	
	RKS569M <input type="checkbox"/> D-◇	PKE569MC	
	RKS596M <input type="checkbox"/> D-◇	PKE596MC	
	RKS599M <input type="checkbox"/> D-◇	PKE599MC	
Standard Type with Encoder	RKS543R <input type="checkbox"/> D2-◇	PKE543RC2	RKSD503- <input type="checkbox"/> D
	RKS544R <input type="checkbox"/> D2-◇	PKE544RC2	
	RKS545R <input type="checkbox"/> D2-◇	PKE545RC2	
	RKS564R <input type="checkbox"/> D2-◇	PKE564RC2	
	RKS566R <input type="checkbox"/> D2-◇	PKE566RC2	
	RKS569R <input type="checkbox"/> D2-◇	PKE569RC2	
	RKS596R <input type="checkbox"/> D2-◇	PKE596RC2	
	RKS599R <input type="checkbox"/> D2-◇	PKE599RC2	
TS Geared Type	RKS543 <input type="checkbox"/> D-TS3.6-◇	PKE543 <input type="checkbox"/> C-TS3.6	RKSD503- <input type="checkbox"/> D
	RKS543 <input type="checkbox"/> D-TS7.2-◇	PKE543 <input type="checkbox"/> C-TS7.2	
	RKS543 <input type="checkbox"/> D-TS10-◇	PKE543 <input type="checkbox"/> C-TS10	
	RKS543 <input type="checkbox"/> D-TS20-◇	PKE543 <input type="checkbox"/> C-TS20	
	RKS543 <input type="checkbox"/> D-TS30-◇	PKE543 <input type="checkbox"/> C-TS30	
	RKS564 <input type="checkbox"/> D-TS3.6-◇	PKE564 <input type="checkbox"/> C-TS3.6	
	RKS564 <input type="checkbox"/> D-TS7.2-◇	PKE564 <input type="checkbox"/> C-TS7.2	
	RKS564 <input type="checkbox"/> D-TS10-◇	PKE564 <input type="checkbox"/> C-TS10	
	RKS564 <input type="checkbox"/> D-TS20-◇	PKE564 <input type="checkbox"/> C-TS20	
	RKS564 <input type="checkbox"/> D-TS30-◇	PKE564 <input type="checkbox"/> C-TS30	
	RKS596 <input type="checkbox"/> D-TS3.6-◇	PKE596 <input type="checkbox"/> C-TS3.6	
	RKS596 <input type="checkbox"/> D-TS7.2-◇	PKE596 <input type="checkbox"/> C-TS7.2	
	RKS596 <input type="checkbox"/> D-TS10-◇	PKE596 <input type="checkbox"/> C-TS10	
	RKS596 <input type="checkbox"/> D-TS20-◇	PKE596 <input type="checkbox"/> C-TS20	
RKS596 <input type="checkbox"/> D-TS30-◇	PKE596 <input type="checkbox"/> C-TS30		
TS Geared Type with Electromagnetic Brake	RKS543M <input type="checkbox"/> D-TS3.6-◇	PKE543MC-TS3.6	RKSD503- <input type="checkbox"/> D
	RKS543M <input type="checkbox"/> D-TS7.2-◇	PKE543MC-TS7.2	
	RKS543M <input type="checkbox"/> D-TS10-◇	PKE543MC-TS10	
	RKS543M <input type="checkbox"/> D-TS20-◇	PKE543MC-TS20	
	RKS543M <input type="checkbox"/> D-TS30-◇	PKE543MC-TS30	
	RKS564M <input type="checkbox"/> D-TS3.6-◇	PKE564MC-TS3.6	
	RKS564M <input type="checkbox"/> D-TS7.2-◇	PKE564MC-TS7.2	
	RKS564M <input type="checkbox"/> D-TS10-◇	PKE564MC-TS10	
	RKS564M <input type="checkbox"/> D-TS20-◇	PKE564MC-TS20	
	RKS564M <input type="checkbox"/> D-TS30-◇	PKE564MC-TS30	
	RKS596M <input type="checkbox"/> D-TS3.6-◇	PKE596MC-TS3.6	
	RKS596M <input type="checkbox"/> D-TS7.2-◇	PKE596MC-TS7.2	
	RKS596M <input type="checkbox"/> D-TS10-◇	PKE596MC-TS10	
	RKS596M <input type="checkbox"/> D-TS20-◇	PKE596MC-TS20	
RKS596M <input type="checkbox"/> D-TS30-◇	PKE596MC-TS30		

● Either **A** (Single shaft) or **B** (Double shaft) indicating the motor shaft configuration is entered where the box is located within the product name.

Either **A** (single-phase 100-120 VAC) or **C** (single-phase 200-240 VAC) indicating the power supply input is entered where the box is located within the product name.

A number indicating the desired length of **1** (1 m), **2** (2 m) or **3** (3 m) for the cable included with the product is entered where the box is located within the product name.

If the package do not include the cable, ◇ is not exists in the product name.

Type	Product Name	Motor Product Name	Driver Product Name
PS Geared Type	RKS545 <input type="checkbox"/> D-PS5-◇	PKE545 <input type="checkbox"/> C-PS5	RKSD503- <input type="checkbox"/> D
	RKS545 <input type="checkbox"/> D-PS7.2-◇	PKE545 <input type="checkbox"/> C-PS7.2	
	RKS545 <input type="checkbox"/> D-PS10-◇	PKE545 <input type="checkbox"/> C-PS10	
	RKS543 <input type="checkbox"/> D-PS25-◇	PKE543 <input type="checkbox"/> C-PS25	
	RKS543 <input type="checkbox"/> D-PS36-◇	PKE543 <input type="checkbox"/> C-PS36	
	RKS543 <input type="checkbox"/> D-PS50-◇	PKE543 <input type="checkbox"/> C-PS50	
	RKS566 <input type="checkbox"/> D-PS5-◇	PKE566 <input type="checkbox"/> C-PS5	RKSD507- <input type="checkbox"/> D
	RKS566 <input type="checkbox"/> D-PS7.2-◇	PKE566 <input type="checkbox"/> C-PS7.2	
	RKS566 <input type="checkbox"/> D-PS10-◇	PKE566 <input type="checkbox"/> C-PS10	
	RKS564 <input type="checkbox"/> D-PS25-◇	PKE564 <input type="checkbox"/> C-PS25	
	RKS564 <input type="checkbox"/> D-PS36-◇	PKE564 <input type="checkbox"/> C-PS36	
	RKS564 <input type="checkbox"/> D-PS50-◇	PKE564 <input type="checkbox"/> C-PS50	
	RKS599 <input type="checkbox"/> D-PS5-◇	PKE599 <input type="checkbox"/> C-PS5	
	RKS599 <input type="checkbox"/> D-PS7.2-◇	PKE599 <input type="checkbox"/> C-PS7.2	
	RKS599 <input type="checkbox"/> D-PS10-◇	PKE599 <input type="checkbox"/> C-PS10	
	RKS596 <input type="checkbox"/> D-PS25-◇	PKE596 <input type="checkbox"/> C-PS25	
RKS596 <input type="checkbox"/> D-PS36-◇	PKE596 <input type="checkbox"/> C-PS36		
RKS596 <input type="checkbox"/> D-PS50-◇	PKE596 <input type="checkbox"/> C-PS50		
PS Geared Type with Electromagnetic Brake	RKS545M <input type="checkbox"/> D-PS5-◇	PKE545MC-PS5	RKSD503- <input type="checkbox"/> D
	RKS545M <input type="checkbox"/> D-PS7.2-◇	PKE545MC-PS7.2	
	RKS545M <input type="checkbox"/> D-PS10-◇	PKE545MC-PS10	
	RKS543M <input type="checkbox"/> D-PS25-◇	PKE543MC-PS25	
	RKS543M <input type="checkbox"/> D-PS36-◇	PKE543MC-PS36	
	RKS543M <input type="checkbox"/> D-PS50-◇	PKE543MC-PS50	
	RKS566M <input type="checkbox"/> D-PS5-◇	PKE566MC-PS5	RKSD507- <input type="checkbox"/> D
	RKS566M <input type="checkbox"/> D-PS7.2-◇	PKE566MC-PS7.2	
	RKS566M <input type="checkbox"/> D-PS10-◇	PKE566MC-PS10	
	RKS564M <input type="checkbox"/> D-PS25-◇	PKE564MC-PS25	
	RKS564M <input type="checkbox"/> D-PS36-◇	PKE564MC-PS36	
	RKS564M <input type="checkbox"/> D-PS50-◇	PKE564MC-PS50	
	RKS599M <input type="checkbox"/> D-PS5-◇	PKE599MC-PS5	
	RKS599M <input type="checkbox"/> D-PS7.2-◇	PKE599MC-PS7.2	
	RKS599M <input type="checkbox"/> D-PS10-◇	PKE599MC-PS10	
	RKS596M <input type="checkbox"/> D-PS25-◇	PKE596MC-PS25	
RKS596M <input type="checkbox"/> D-PS36-◇	PKE596MC-PS36		
RKS596M <input type="checkbox"/> D-PS50-◇	PKE596MC-PS50		
Harmonic Geared Type	RKS543 <input type="checkbox"/> D-HS50-◇	PKE543 <input type="checkbox"/> C-HS50	RKSD503- <input type="checkbox"/> D
	RKS543 <input type="checkbox"/> D-HS100-◇	PKE543 <input type="checkbox"/> C-HS100	RKSD507- <input type="checkbox"/> D
	RKS564 <input type="checkbox"/> D-HS50-◇	PKE564 <input type="checkbox"/> C-HS50	
	RKS564 <input type="checkbox"/> D-HS100-◇	PKE564 <input type="checkbox"/> C-HS100	
	RKS596 <input type="checkbox"/> D-HS50-◇	PKE596 <input type="checkbox"/> C-HS50	
	RKS596 <input type="checkbox"/> D-HS100-◇	PKE596 <input type="checkbox"/> C-HS100	
Harmonic Geared Type with Electromagnetic Brake	RKS543M <input type="checkbox"/> D-HS50-◇	PKE543MC-HS50	RKSD503- <input type="checkbox"/> D
	RKS543M <input type="checkbox"/> D-HS100-◇	PKE543MC-HS100	RKSD507- <input type="checkbox"/> D
	RKS564M <input type="checkbox"/> D-HS50-◇	PKE564MC-HS50	
	RKS564M <input type="checkbox"/> D-HS100-◇	PKE564MC-HS100	
	RKS596M <input type="checkbox"/> D-HS50-◇	PKE596MC-HS50	
	RKS596M <input type="checkbox"/> D-HS100-◇	PKE596MC-HS100	

- Either **A** (Single shaft) or **B** (Double shaft) indicating the motor shaft configuration is entered where the box is located within the product name.
- Either **A** (single-phase 100-120 VAC) or **C** (single-phase 200-240 VAC) indicating the power supply input is entered where the box is located within the product name.
- A number indicating the desired length of **1** (1 m), **2** (2 m) or **3** (3 m) for the cable included with the product is entered where the box is located within the product name.
- If the package do not include the cable, ◇ is not exists in the product name.

Pulse Input Type

Type	Product Name	Motor Product Name	Driver Product Name
Standard Type	RKS543□-◇	PKE543□C	RKSD503-□
	RKS544□-◇	PKE544□C	
	RKS545□-◇	PKE545□C	
	RKS564□-◇	PKE564□C	RKSD507-□
	RKS566□-◇	PKE566□C	
	RKS569□-◇	PKE569□C	
	RKS596□-◇	PKE596□C	
	RKS599□-◇	PKE599□C	
RKS5913□-◇	PKE5913□C		
Standard Type with Electromagnetic Brake	RKS543M□-◇	PKE543MC	RKSD503M-□
	RKS544M□-◇	PKE544MC	
	RKS545M□-◇	PKE545MC	
	RKS564M□-◇	PKE564MC	RKSD507M-□
	RKS566M□-◇	PKE566MC	
	RKS569M□-◇	PKE569MC	
	RKS596M□-◇	PKE596MC	
	RKS599M□-◇	PKE599MC	
RKS5913M□-◇	PKE5913MC		
TS Geared Type	RKS543□-TS3.6-◇	PKE543□C-TS3.6	RKSD503-□
	RKS543□-TS7.2-◇	PKE543□C-TS7.2	
	RKS543□-TS10-◇	PKE543□C-TS10	
	RKS543□-TS20-◇	PKE543□C-TS20	RKSD507-□
	RKS543□-TS30-◇	PKE543□C-TS30	
	RKS564□-TS3.6-◇	PKE564□C-TS3.6	
	RKS564□-TS7.2-◇	PKE564□C-TS7.2	
	RKS564□-TS10-◇	PKE564□C-TS10	
	RKS564□-TS20-◇	PKE564□C-TS20	
	RKS564□-TS30-◇	PKE564□C-TS30	
	RKS596□-TS3.6-◇	PKE596□C-TS3.6	
	RKS596□-TS7.2-◇	PKE596□C-TS7.2	
RKS596□-TS10-◇	PKE596□C-TS10		
RKS596□-TS20-◇	PKE596□C-TS20		
RKS596□-TS30-◇	PKE596□C-TS30		
TS Geared Type with Electromagnetic Brake	RKS543M□-TS3.6-◇	PKE543MC-TS3.6	RKSD503M-□
	RKS543M□-TS7.2-◇	PKE543MC-TS7.2	
	RKS543M□-TS10-◇	PKE543MC-TS10	
	RKS543M□-TS20-◇	PKE543MC-TS20	RKSD507M-□
	RKS543M□-TS30-◇	PKE543MC-TS30	
	RKS564M□-TS3.6-◇	PKE564MC-TS3.6	
	RKS564M□-TS7.2-◇	PKE564MC-TS7.2	
	RKS564M□-TS10-◇	PKE564MC-TS10	
	RKS564M□-TS20-◇	PKE564MC-TS20	
	RKS564M□-TS30-◇	PKE564MC-TS30	
	RKS596M□-TS3.6-◇	PKE596MC-TS3.6	
	RKS596M□-TS7.2-◇	PKE596MC-TS7.2	
RKS596M□-TS10-◇	PKE596MC-TS10		
RKS596M□-TS20-◇	PKE596MC-TS20		
RKS596M□-TS30-◇	PKE596MC-TS30		

● Either **A** (Single shaft) or **B** (Double shaft) indicating the motor shaft configuration is entered where the box □ is located within the product name.

Either **A** (single-phase 100-120 VAC) or **C** (single-phase 200-240 VAC) indicating the power supply input is entered where the box □ is located within the product name.

A number indicating the desired length of **1** (1 m), **2** (2 m) or **3** (3 m) for the cable included with the product is entered where the box ◇ is located within the product name.

If the package do not include the cable, ◇ is not exists in the product name.

Type	Product Name	Motor Product Name	Driver Product Name
PS Geared Type	RKS545-PS5-◇	PKE545-C-PS5	RKSD503-
	RKS545-PS7.2-◇	PKE545-C-PS7.2	
	RKS545-PS10-◇	PKE545-C-PS10	
	RKS543-PS25-◇	PKE543-C-PS25	
	RKS543-PS36-◇	PKE543-C-PS36	
	RKS543-PS50-◇	PKE543-C-PS50	
	RKS566-PS5-◇	PKE566-C-PS5	RKSD507-
	RKS566-PS7.2-◇	PKE566-C-PS7.2	
	RKS566-PS10-◇	PKE566-C-PS10	
	RKS564-PS25-◇	PKE564-C-PS25	
	RKS564-PS36-◇	PKE564-C-PS36	
	RKS564-PS50-◇	PKE564-C-PS50	
	RKS599-PS5-◇	PKE599-C-PS5	
	RKS599-PS7.2-◇	PKE599-C-PS7.2	
	RKS599-PS10-◇	PKE599-C-PS10	
	RKS596-PS25-◇	PKE596-C-PS25	
RKS596-PS36-◇	PKE596-C-PS36		
RKS596-PS50-◇	PKE596-C-PS50		
PS Geared Type with Electromagnetic Brake	RKS545M-PS5-◇	PKE545MC-PS5	RKSD503M-
	RKS545M-PS7.2-◇	PKE545MC-PS7.2	
	RKS545M-PS10-◇	PKE545MC-PS10	
	RKS543M-PS25-◇	PKE543MC-PS25	
	RKS543M-PS36-◇	PKE543MC-PS36	
	RKS543M-PS50-◇	PKE543MC-PS50	
	RKS566M-PS5-◇	PKE566MC-PS5	RKSD507M-
	RKS566M-PS7.2-◇	PKE566MC-PS7.2	
	RKS566M-PS10-◇	PKE566MC-PS10	
	RKS564M-PS25-◇	PKE564MC-PS25	
	RKS564M-PS36-◇	PKE564MC-PS36	
	RKS564M-PS50-◇	PKE564MC-PS50	
	RKS599M-PS5-◇	PKE599MC-PS5	
	RKS599M-PS7.2-◇	PKE599MC-PS7.2	
	RKS599M-PS10-◇	PKE599MC-PS10	
	RKS596M-PS25-◇	PKE596MC-PS25	
RKS596M-PS36-◇	PKE596MC-PS36		
RKS596M-PS50-◇	PKE596MC-PS50		
Harmonic Geared Type	RKS543-HS50-◇	PKE543-C-HS50	RKSD503-
	RKS543-HS100-◇	PKE543-C-HS100	RKSD507-
	RKS564-HS50-◇	PKE564-C-HS50	
	RKS564-HS100-◇	PKE564-C-HS100	
	RKS596-HS50-◇	PKE596-C-HS50	
	RKS596-HS100-◇	PKE596-C-HS100	
Harmonic Geared Type with Electromagnetic Brake	RKS543M-HS50-◇	PKE543MC-HS50	RKSD503M-
	RKS543M-HS100-◇	PKE543MC-HS100	RKSD507M-
	RKS564M-HS50-◇	PKE564MC-HS50	
	RKS564M-HS100-◇	PKE564MC-HS100	
	RKS596M-HS50-◇	PKE596MC-HS50	
	RKS596M-HS100-◇	PKE596MC-HS100	

- Either **A** (Single shaft) or **B** (Double shaft) indicating the motor shaft configuration is entered where the box □ is located within the product name.
- Either **A** (single-phase 100-120 VAC) or **C** (single-phase 200-240 VAC) indicating the power supply input is entered where the box □ is located within the product name.
- A number indicating the desired length of **1** (1 m), **2** (2 m) or **3** (3 m) for the cable included with the product is entered where the box □ is located within the product name.
- If the package do not include the cable, ◇ is not exists in the product name.

Accessories (Sold Separately)

Connection Cable Sets (RoHS), Flexible Connection Cable Sets (RoHS) Extension Cable Sets (RoHS), Flexible Extension Cable Sets (RoHS)

Cable connects the Motor to Driver for **RKII** series, we provide both of “with cable package (1 m, 2 m or 3 m)” and “without cable package”, the user can choose either meet the requirement.

If the user need a cable longer than 3 m or flexible cable, please select an appropriate cable from among the accessories (sold separately).

Keep the wiring distance between the motor and driver to 20 m max.

System Configuration

- Connect the motor and driver without using the cable which came with the product.
 - Use a connection cable set
 - Use a flexible cable set if the cable will be bend.

◇ For Standard Type or Standard Type with Electromagnetic Brake

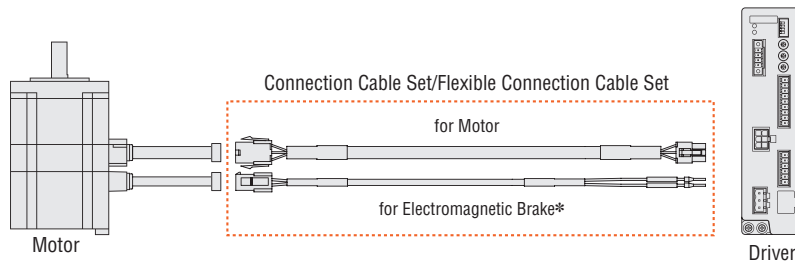

* Electromagnetic Brake Cable is required for the Motor with Electromagnetic Brake.

◇ For Motor with Encoder

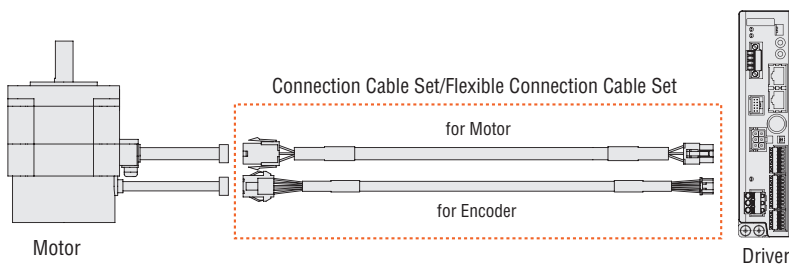

- Connect and extend the Motor and Driver by using cable included in package
 - Use the Extension Cable Set combination with the cable came with the product.
 - Use a flexible cable set if the cable will be bend.

◇ For Standard Type or Electromagnetic Brake Motor

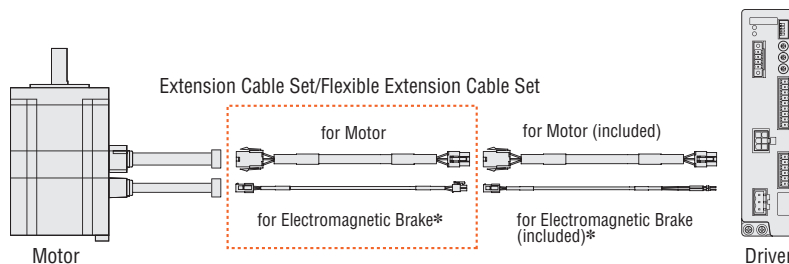

* Electromagnetic Brake Cable is required for the Motor with Electromagnetic Brake.

◇ For Motor with Encoder

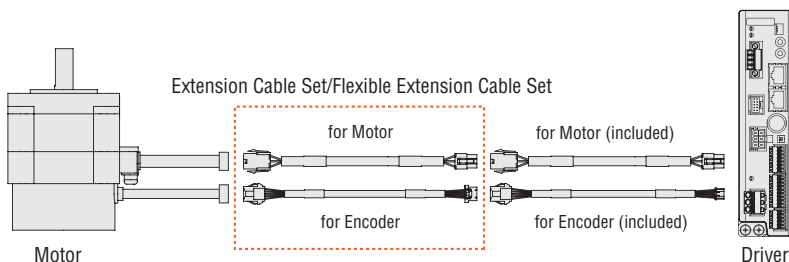

Note

- Keep the total cable length below 20 m when connecting a cable included in the **RKII** Series and an extension cable.
- The cable on the Electromagnetic Brake or Encoder cannot be connected to the driver directly. To connect to the driver, connection cable (accessory, sold separately) is needed. Otherwise please select the package which comes with the connection cable (The package includes connection cable).

Connection Cable Sets (RoHS), Flexible Connection Cable Sets (RoHS)

Product Line

Connection Cable Sets

◇ For Standard Motor



Motor Cable

Product Name	Length L (m)
CC010VPF	1
CC020VPF	2
CC030VPF	3
CC050VPF	5
CC070VPF	7
CC100VPF	10
CC150VPF	15
CC200VPF	20

◇ For Electromagnetic Brake Motor



Motor Cable



Electromagnetic Brake Cable

Product Name	Length L (m)
CC010VPFB	1
CC020VPFB	2
CC030VPFB	3
CC050VPFB	5
CC070VPFB	7
CC100VPFB	10
CC150VPFB	15
CC200VPFB	20

◇ For Encoder Motor



Motor Cable



Encoder Cable

Product Name	Length L (m)
CC010VPFE	1
CC020VPFE	2
CC030VPFE	3
CC050VPFE	5
CC070VPFE	7
CC100VPFE	10
CC150VPFE	15
CC200VPFE	20

Flexible Connection Cable Sets

◇ For Standard Motor



Motor Cable

Product Name	Length L (m)
CC010VPR	1
CC020VPR	2
CC030VPR	3
CC050VPR	5
CC070VPR	7
CC100VPR	10
CC150VPR	15
CC200VPR	20

◇ For Electromagnetic Brake Motor



Motor Cable



Electromagnetic Brake Cable

Product Name	Length L (m)
CC010VPRB	1
CC020VPRB	2
CC030VPRB	3
CC050VPRB	5
CC070VPRB	7
CC100VPRB	10
CC150VPRB	15
CC200VPRB	20

◇ For Encoder Motor



Motor Cable



Encoder Cable

Product Name	Length L (m)
CC010VPRE	1
CC020VPRE	2
CC030VPRE	3
CC050VPRE	5
CC070VPRE	7
CC100VPRE	10
CC150VPRE	15
CC200VPRE	20

Extension Cable Sets (RoHS), Flexible Extension Cable Sets (RoHS)

Product Line

Extension Cable Sets

◇ For Standard Motor



Motor Cable

Product Name	Length L (m)
CC010VPF	1
CC020VPF	2
CC030VPF	3
CC050VPF	5
CC070VPF	7
CC100VPF	10
CC150VPF	15

◇ For Electromagnetic Brake Motor



Motor Cable



Electromagnetic Brake Cable

Product Name	Length L (m)
CC010VPFBT	1
CC020VPFBT	2
CC030VPFBT	3
CC050VPFBT	5
CC070VPFBT	7
CC100VPFBT	10
CC150VPFBT	15

◇ For Encoder Motor



Motor Cable



Encoder Cable

Product Name	Length L (m)
CC010VPFET	1
CC020VPFET	2
CC030VPFET	3
CC050VPFET	5
CC070VPFET	7
CC100VPFET	10
CC150VPFET	15

Flexible Extension Cable Sets

◇ For Standard Motor



Motor Cable

Product Name	Length L (m)
CC010VPR	1
CC020VPR	2
CC030VPR	3
CC050VPR	5
CC070VPR	7
CC100VPR	10
CC150VPR	15

◇ For Electromagnetic Brake Motor



Motor Cable



Electromagnetic Brake Cable

Product Name	Length L (m)
CC010VPRBT	1
CC020VPRBT	2
CC030VPRBT	3
CC050VPRBT	5
CC070VPRBT	7
CC100VPRBT	10
CC150VPRBT	15

◇ For Encoder Motor



Motor Cable



Encoder Cable

Product Name	Length L (m)
CC010VPRET	1
CC020VPRET	2
CC030VPRET	3
CC050VPRET	5
CC070VPRET	7
CC100VPRET	10
CC150VPRET	15

Dimensions Unit = mm (in.)

Connection Cable

Motor Cable

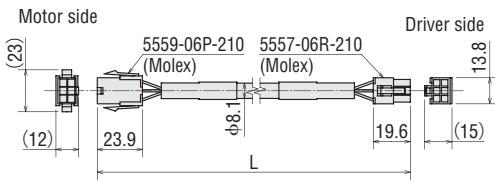

Electromagnetic Brake Cable

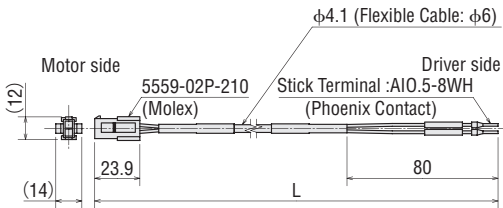

Encoder Cable

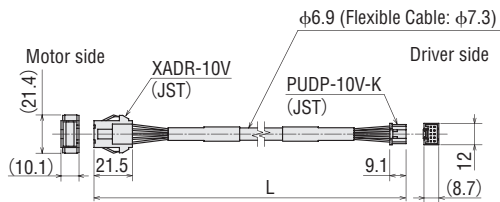

Extension Cable

Motor Cable

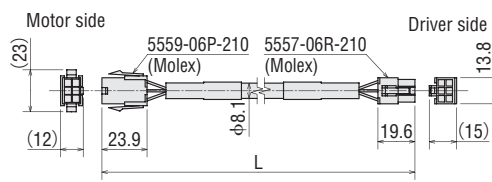

Electromagnetic Brake Cable

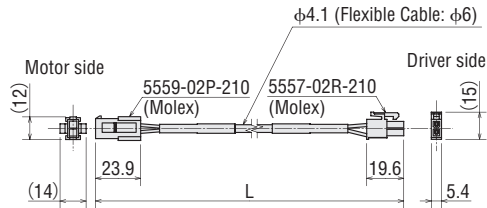

Encoder Cable

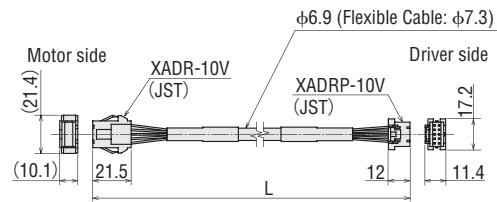

Notes on Use of a Flexible Cable

① Do not allow the cable to bend at the cable connector.

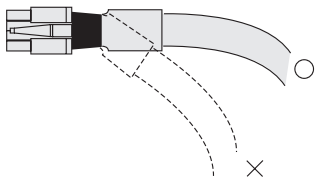

② For the bending radius, use at six times or more of the cable diameter.

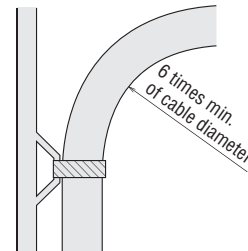

③ The cable wired from the motor or the cable comes as a set of the motor should not be bended. Use a flexible motor cable, if the cable will be bend.

• Flexible Connection Cable

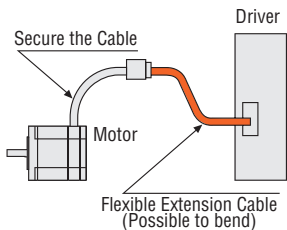

• Flexible Extension Cable

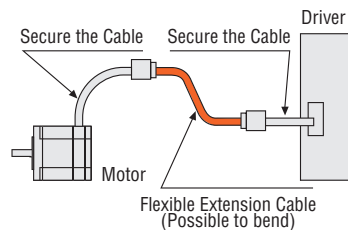

Flexible Couplings

Flexible Couplings compatible for **RKII** series are available.
The user can select easily depending on size/purpose of the motor or gear.



Coupling Selection

Coupling Type	Motor Type			Purpose
	Standard Type	TS Geared Type PS Geared Type Harmonic Geared Type		
MCV Coupling	⊙	-		High accuracy positioning, control vibration
MCS Coupling	○	⊙		High strength and High accuracy positioning

Models and characteristics of coupling

● MCV Couplings

One piece contains antivibration rubber and aluminum base alloy.
High in torsional stiffness because it has same characteristics for both normal rotation and reverse rotation, suitable for high accuracy positioning operation for stepping motor.

◇ Features

- An antivibration rubber reduces the vibration generated at the motor.
- High response.
- No backlash.
- Electrical insulating properties.



● MCS Couplings

This coupling has three pieces structure contains an Aluminum Hub, a spider (material: polyurethane).
The simple structure can transmit high-torque such as torque on geared type reliably.

◇ Features

- High strength (usable for geared motor) is now available.
- No backlash.
- Controls the vibration generated by the motor.



Selecting a Coupling

● Standard Type

The following examples explain the procedures in selecting a coupling by driven shaft diameter and product name.

Example: Product Name: **RKS566AC-1** Driven Shaft Diameter: $\phi 8$ mm

1. The coupling type that matches **RKS566AC-1** from the coupling selection table is **MCV25**.
2. The inner diameter of the coupling according to the motor shaft will be **10** ($\phi 10$ mm), and will be **8** ($\phi 8$ mm) according to the driven shaft diameter.
3. In the coupling product name, smaller inner diameters come before larger ones, thus the coupling product name will be **MCV250810**, **MC250810S** (Set screw type).

● When the inner diameter is $\phi 6.35$ mm, the number is **06A**. For example, when the coupling type is **MCV25**, the motor shaft diameter is **10** ($\phi 10$ mm), and the driven shaft diameter is **06A** ($\phi 6.35$ mm), the coupling product name will be **MCV2506A10**.

● TS Geared Type, PS Geared Type and Harmonic Geared Type

The following examples explain the procedures in selecting a coupling by driven shaft diameter and product name.

Example: Product Name: **RKS545AC-PS10-1** Driven Shaft Diameter: $\phi 12$ mm

1. The coupling type that matches **RKS545AC-PS10-1** from the coupling selection table is **MCS30**.
2. The inner diameter of the coupling according to the motor shaft will be **10** ($\phi 10$ mm), and will be **12** ($\phi 12$ mm) according to the driven shaft diameter.
3. In the coupling product name, smaller inner diameters come before larger ones, thus the coupling product name will be **MCS301012**.

● When the inner diameter is $\phi 6.35$ mm, the number is **F04**. For example, when the coupling type is **MCS30**, the motor shaft diameter is **06** ($\phi 6$ mm), and the driven shaft diameter is **F04** ($\phi 6.35$ mm), the coupling product name will be **MCS3006F04**.

MCV Couplings RoHS



Product Line

Product Name
MCV15 <input type="checkbox"/>
MCV19 <input type="checkbox"/>
MCV25 <input type="checkbox"/>
MCV30 <input type="checkbox"/>

● A number indicating the coupling inner diameter is entered where the box is located within the product name.

Product Number Code

MCV 30 10 14

① ② ③ ④

①	MCV Couplings
②	Outer Diameter of Coupling
③	Inner Diameter d1 (smaller inner diameter) (06A represents $\phi 6.35$ mm)
④	Inner Diameter d2 (larger inner diameter) (06A represents $\phi 6.35$ mm)

● For inner diameter d1, the smaller of the motor shaft diameter or the driven shaft diameter is entered.
 For inner diameter d2, the larger of the motor shaft diameter or the driven shaft diameter is entered.

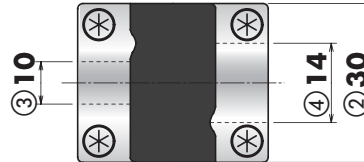

Coupling Selection Table

- Coupling is selected based on the following content.
 - The motor output torque is within the generic torque for coupling.
 - Motor shaft diameter

Type	Frame Size	Product Name	Coupling Type	Motor Shaft Diameter mm		Driven Shaft Diameter mm									
						04	05	06	06A	08	10	12	14	15	
						$\phi 4$	$\phi 5$	$\phi 6$	$\phi 6.35$	$\phi 8$	$\phi 10$	$\phi 12$	$\phi 14$	$\phi 15$	
Standard Type	42 mm	RKS543 RKS544 RKS545	MCV15	06	$\phi 6$	●	●	●							
	60 mm	RKS564 RKS566 RKS569	MCV25	10	$\phi 10$			●	●	●	●	●			
	85 mm	RKS596 RKS599 RKS5913	MCV30	14	$\phi 14$					●	●	●	●	●	●

● The applicable product name includes the characters that can distinguish the product name.

For more detail, refer to our website or contact to the customer center.

<http://www.orientalmotor.eu>

MCS Couplings RoHS



Product Line

Product Name
MCS20 <input type="checkbox"/>
MCS30 <input type="checkbox"/>
MCS40 <input type="checkbox"/>
MCS55 <input type="checkbox"/>
MCS65 <input type="checkbox"/>

● A number indicating the coupling inner diameter is entered where the box is located within the product name.

Product Number Code

MCS 30 08 12

① ② ③ ④

①	MCS Couplings
②	Outer Diameter of Coupling
③	Inner Diameter d1 (smaller inner diameter) (F04 represents $\phi 6.35$ mm)
④	Inner Diameter d2 (larger inner diameter) (F04 represents $\phi 6.35$ mm)

● For inner diameter d1, the smaller of the motor shaft diameter or the driven shaft diameter is entered.
 For inner diameter d2, the larger of the motor shaft diameter or the driven shaft diameter is entered.

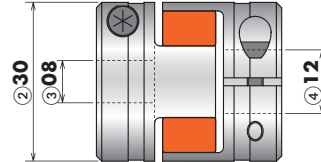

Coupling Selection Table

- Coupling is selected based on the following content.
 - The motor output torque is within the generic torque for coupling.
 - Motor shaft diameter

Type	Frame Size	Product Name	Gear Ratio	Coupling Type	Motor Shaft Diameter mm	Driven Shaft Diameter mm															
						05	06	F04	08	10	12	14	15	16	18	20	22	24	25		
						$\phi 5$	$\phi 6$	$\phi 6.35$	$\phi 8$	$\phi 10$	$\phi 12$	$\phi 14$	$\phi 15$	$\phi 16$	$\phi 18$	$\phi 20$	$\phi 22$	$\phi 24$	$\phi 25$		
TS Geared Type	42 mm	RKS543	3.6, 7.2, 10, 20, 30	MCS20	06 $\phi 6$	●	●	●	●	●											
	60 mm	RKS564	3.6, 7.2, 10, 20, 30	MCS30	10 $\phi 10$		●	●	●	●	●	●	●								
	90 mm	RKS596	3.6, 7.2, 10, 20, 30	MCS55	18 $\phi 14$						●	●	●	●	●	●	●	●			
PS Geared Type	42 mm	RKS545	5, 7.2	MCS20	10 $\phi 10$	●	●	●	●	●											
			10	MCS30	10 $\phi 10$		●	●	●	●	●	●	●								
	60 mm	RKS543	25, 36, 50	MCS40	10 $\phi 10$				●	●	●	●	●	●	●	●	●	●			
		RKS566	5	MCS40	12 $\phi 12$				●	●	●	●	●	●	●	●	●	●			
		RKS564	7.2, 10	MCS55	12 $\phi 12$						●	●	●	●	●	●	●	●	●	●	
	90 mm	RKS599	25, 36, 50	MCS55	12 $\phi 12$						●	●	●	●	●	●	●	●	●	●	
		RKS599	5	MCS55	18 $\phi 18$						●	●	●	●	●	●	●	●	●	●	
RKS596	7.2, 10	MCS65	18 $\phi 18$										●	●	●	●	●	●	●		
Harmonic Geared Type	42 mm	RKS543	50, 100	MCS40	10 $\phi 10$				●	●	●	●	●	●	●	●					
	60 mm	RKS564		MCS55	15 $\phi 15$						●	●	●	●	●	●	●	●	●		
	90 mm	RKS596		MCS65	22 $\phi 22$											●	●				

● The applicable product name includes the characters that can distinguish the product name.

For more detail, refer to our website or contact to the customer center.

<http://www.orientalmotor.eu>

Motor Mounting Brackets RoHS

Mounting brackets are convenient for installation and securing a stepping motor and geared stepping motor.

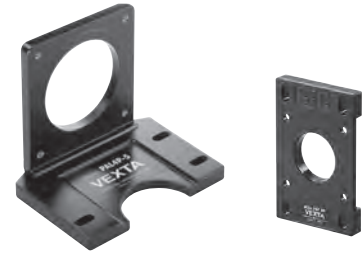

Product Line

Standard Type

Material: Aluminum Alloy

Product Name	Motor Frame Size	Applicable Product
PAFOP	42 mm	RKS543 RKS544 RKS545
PALOP		
PAL2P-5	60 mm	RKS564 RKS566 RKS569
PAL4P-5	85 mm	RKS596 RKS599 RKS5913

- The mounting bracket base is built with holes large enough to allow for alignment adjustments in the horizontal direction.
- These mounting brackets can be perfectly fitted to the pilot of the stepping motors. (Except for **PALOP**)

TS Geared Type

Material: Aluminum Alloy

Product Name	Motor Frame Size	Applicable Product
SOLOB	42 mm	RKS543
SOL2M4	60 mm	RKS564
SOL5M8	90 mm	RKS596

PS Geared Type

Material: SS400

Surface Treatment: Electroless nickel plating

Product Name	Motor Frame Size	Applicable Product
PLA60G	60 mm	RKS564 RKS566
PLA90G	90 mm	RKS596 RKS599

- The mounting bracket base is built with holes large enough to allow for alignment adjustments in the horizontal direction.
- Motor Mounting Screws are included.

Harmonic Geared Type

Material: SS400

Surface Treatment: Electroless nickel plating

Product Name	Motor Frame Size	Applicable Product
PLA60H	60 mm	RKS564
PLA90H	90 mm	RKS596

- Fixed portion on mounting bracket is slotting shaped, it make easy to adjust tension of belt after mounting the motor.
- Motor Mounting Screws are included.

The other shapes of mounting bracket are also available.
For more detail, please contact to our branch/ sales office or visit our website.
<http://www.orientalmotor.eu>

Motor Mounting Direction

The motor cable comes out at right angles to the motor. Orient the motor so that the cable faces either upward or sideways.

- For **PLA60G, PLA90G, PLA60H, PLA90H**: The cable can face downward.

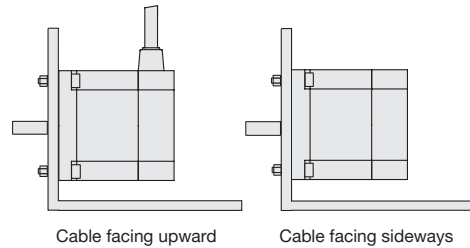

How to mount the motor

1 PAL2P-5, PAL4P-5 SOL2M4, SOL5M8

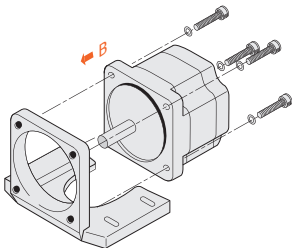

- ① Use the screws provided to secure the motor to the mounting bracket.
- ② Attach the motor from the direction shown by the arrow (B).

2 PALOP, SOLOB

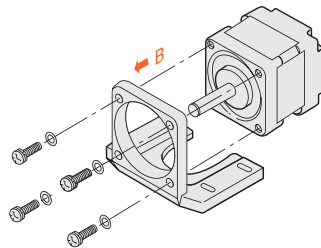

- ① Use the screws provided to secure the motor to the mounting bracket.
- ② Attach the motor from the direction shown by the arrow (B).

3 PAFOP

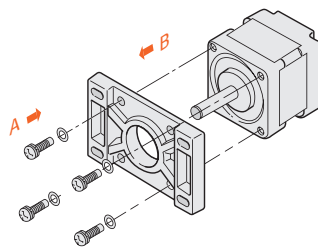

- ① Use the screws provided to secure the motor to the mounting bracket.
- ② Attach motor from the direction shown by either arrow (A) or arrow (B).

4 PLA60G, PLA90G PLA60H, PLA90H

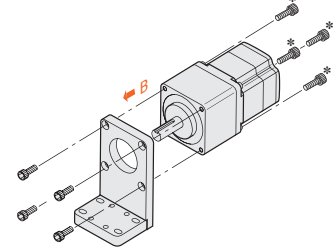

- ① Use the screws provided to secure the motor to the mounting bracket.
- ② Attach the motor from the direction shown by the arrow (B).

*Motor mounting hole on **PLA90H** is processed with tapping. Insert the screw from direction B.

Dimensions (Unit = mm)

PALOP

Mass : 35 g

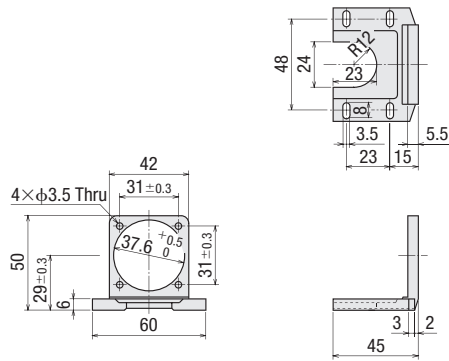

- Mounting Screws : M3 Length 10 mm
Included 4 pieces

PAFOP

Mass : 30 g

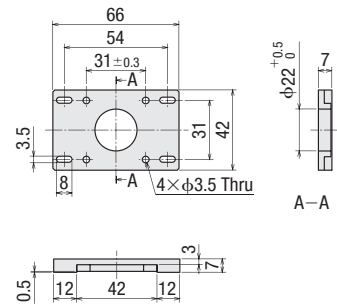

- Mounting Screws : M3 Length 7 mm
Included 4 pieces

PAL2P-5

Mass : 110 g

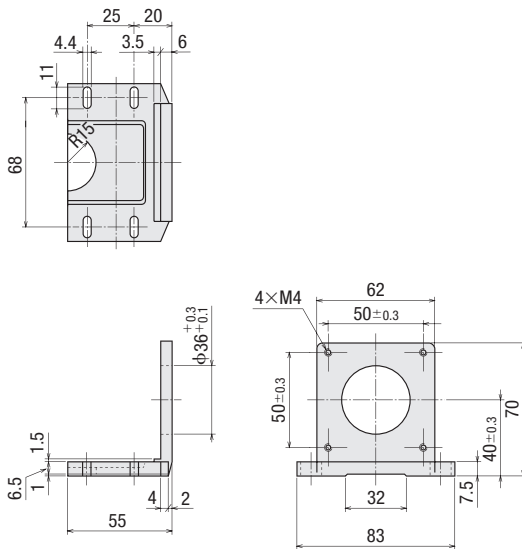

- Mounting Screws : M4 Length 12 mm
Included 4 pieces

PAL4P-5

Mass : 250 g

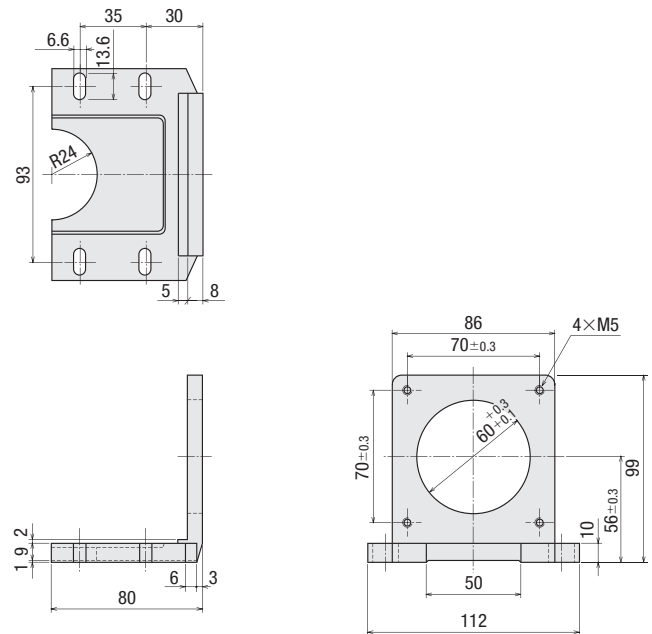

- Mounting Screws : M5 Length 16 mm
Included 4 pieces

SOL0B

Mass : 85 g

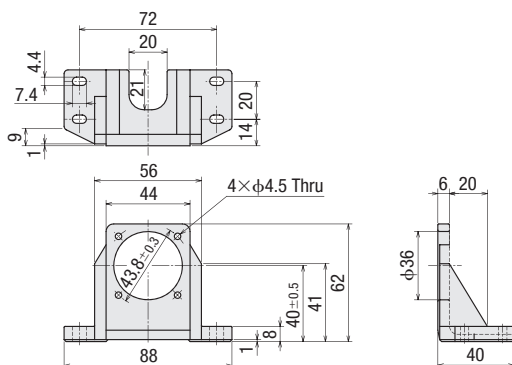

SOL2M4

Mass : 135 g

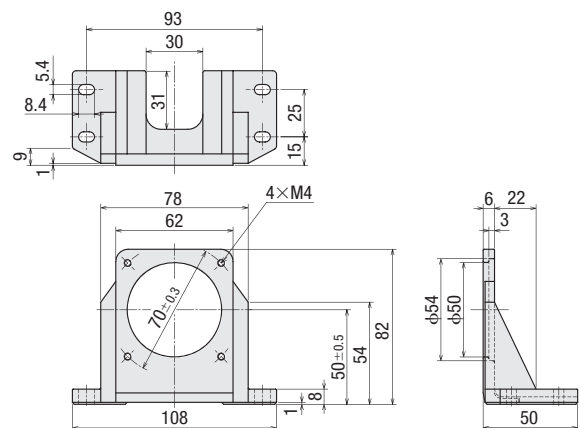

SOL5M8

Mass : 270 g

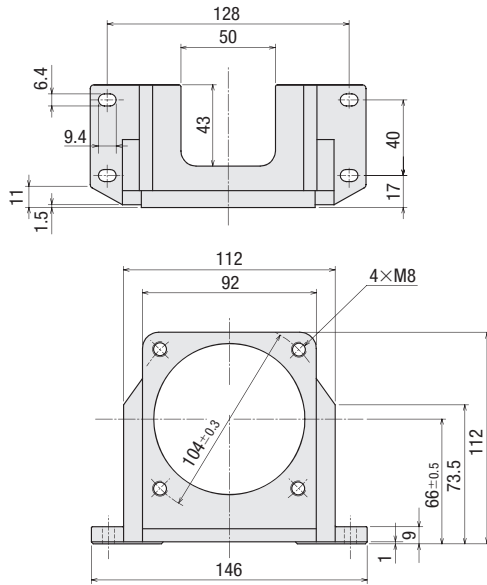

PLA60G

Mass : 0.7 kg

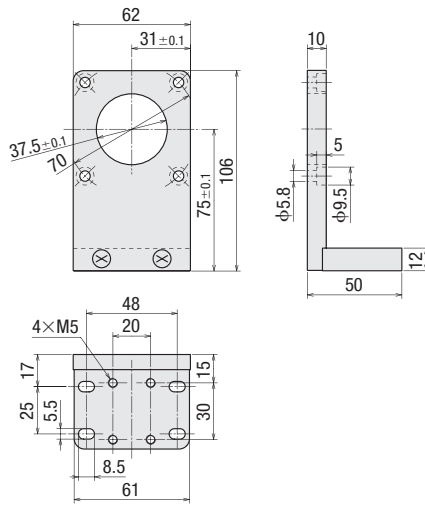

● Mounting Screws : M5 Length 15 mm
Included 4 pieces

PLA90G

Mass : 1.6 kg

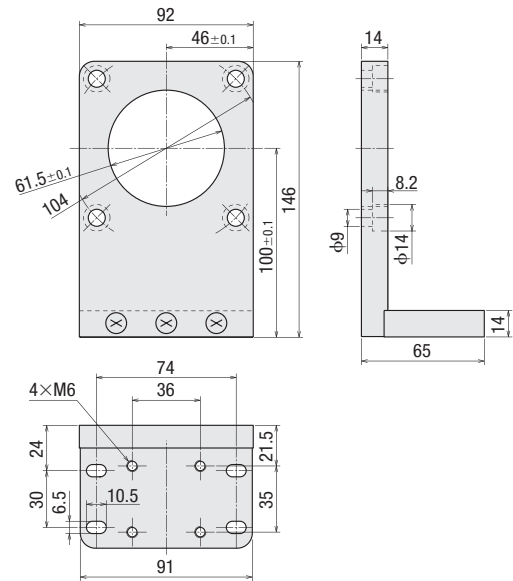

● Mounting Screws : M8 Length 20 mm
Included 4 pieces

DIN rail mounting bracket RoHS

Use to mount the driver on DIN rail.

Product Line

Material: SPCC Surface Treatment: Trivalent Chromate

Product Name

MADP02



● DIN rail should be mounted on highly thermal conductive flat metal plate (comparable to 200 mm x 200 mm x 2 mm).
Be sure to keep the ambient temperature of the driver 0~+40°C.

Communication Cable for Data Setting Software RoHS

The cable to connect the PC with data setting software and driver installed.

Product Line

Product Name	Applicable Product
CC051F-USB	Built-in Controller Type



Connection between Computer and Driver

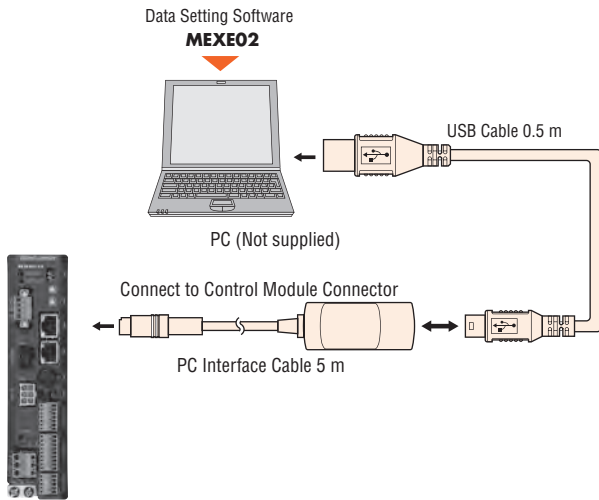

Note

● To connect with PC, exclusive device driver should be installed.

Data Setting Software **MEXE02**

Data Setting Software can be downloaded from our website.
For more detail, please contact our website or contact our branch/sales office.
<http://www.orientalmotor.eu>

Operating Environment

Operating Systems

- Microsoft Windows 2000 Professional Service Pack 4 Rollup 1 provided by Microsoft Corp. must be applied. To confirm application of Rollup 1, please check it at “Add or Remove Programs.”

For following OS, supports only 32-bit (x86) or 64-bit (x64) version.

- Microsoft Windows XP Home Edition Service Pack 3
- Microsoft Windows XP Professional Service Pack 2
- Microsoft Windows XP Professional Service Pack 3*
- Microsoft Windows Vista Home Basic Service Pack 2
- Microsoft Windows Vista Home Premium Service Pack 2
- Microsoft Windows Vista Business Service Pack 2
- Microsoft Windows Vista Ultimate Service Pack 2
- Microsoft Windows Vista Enterprise Service Pack 2
- Microsoft Windows 7 Starter Service Pack 1
- Microsoft Windows 7 Home Premium Service Pack 1
- Microsoft Windows 7 Professional Service Pack 1
- Microsoft Windows 7 Ultimate Service Pack 1
- Microsoft Windows 7 Enterprise Service Pack 1
- Microsoft Windows 8

* Supports 32-bit (x86) version only

Computer

Recommended CPU*1	Intel Core Processor 2 GHz or more (The OS must be supported.)
Display	high resolution video adapter and monitor, XGA (1024x768) or more.
Recommended Memory*1	32-bit (x86) version: 1 GB or more 64-bit (x64) version: 2 GB or more
Hard Disk*2	Available disk space of 30 MB or more
USB Port	USB 1.1 1 port

*1 The OS operating conditions must be satisfied.

*2 Microsoft .NET Framework 4 Client Profile is required to use **MEXE02**. If it is not already installed, it will be installed automatically, in which case up to 1.5 GB MB of additional space is required.

- Windows and Windows Vista are registered trademark of Microsoft Corporation in the United States and other countries. Pentium is a trademark of Intel Corporation.

- Please refer to our website for the latest update of operating environment.

Note

- The required volume of memory or hard disk may vary depending on the system environment.

Control Module RoHS

The internal driver parameter settings and data settings can be established and changed. They can also be used for speed and I/O monitoring, teaching, and so on.

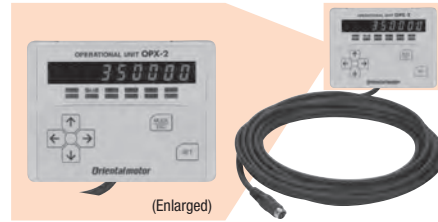

Product Line

Product Name	Applicable Product
OPX-2A	Built-in Controller Type

Dimensions (Unit = mm)

Control Module

Mass : 0.25 kg

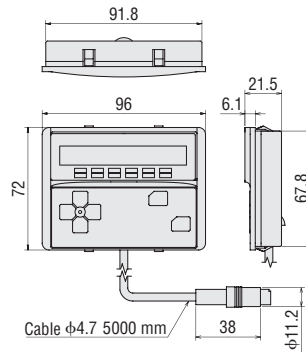

Panel Cut-Out for Control Module

(Thickness of the mounting plate: 1~3 mm)

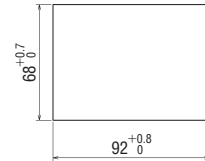

Driver Cable

General-Purpose Cables RoHS



General-purpose multiconductor cable which is convenient for connection between the driver and the host controller.

Product Line

Product Name	Length (m)
CC16D005B-1	0.5
CC16D010B-1	1.0
CC16D015B-1	1.5
CC16D020B-1	2.0

Dimensions (Unit = mm)

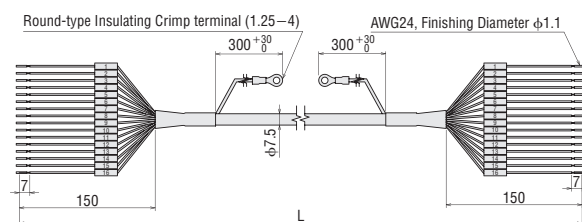

RS-485 Communication Cable RoHS

The cable is to link drivers when the driver is being operated under multi-axis mode, it also connects the network converter and driver.



Product Line

Product Name	Length (m)	Applicable Product
CC002-RS4	0.25	Built-in Controller Type

Dimensions (Unit = mm)

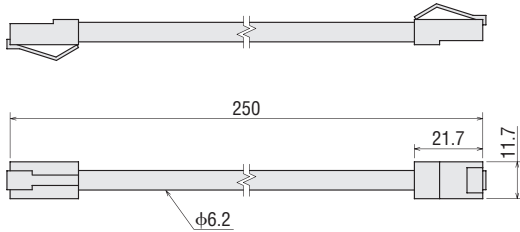

● Example of connection

RS-485 Communication Connector (CN6/CN7)

Link between drivers is available

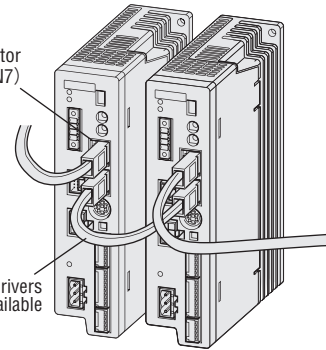

Network Convertors RoHS

Network converter is a transducer from the host communication protocol to our unique RS-485 communication protocol. By using this network converter, our RS-485 compatible products can be controlled under host communication environment.

Product Line

Network Type	Product Name
EtherCAT Compatible	NETC01-ECT
CC-Link Ver. 1.1 Compatible	NETC01-CC
CC-Link Ver. 2 Compatible	NETC02-CC
MECHATROLINK - II Compatible	NETC01-M2
MECHATROLINK - III Compatible	NETC01-M3



Controllers RoHS

Use the **SCX11** controller as a stored program controller to connect to any or Oriental Motor's standard pulse input drivers. The SCX11 is also able to control the motor via various serial ports such as USB, RS-232C and CANopen.



- Easy Installation
- Easy Operation, Friendly PC Software (Windows GUI software)
- Two Types of Operation: Direct Command Operation and Executing Sequence Operation (Stored Program Function)

Product Line

Product Name	Driver Product Name
SCX11	RKSD503-□, RKSD507-□, RKSD503M-□, RKSD507M-□

Either **A** (single-phase 100-120 VAC) or **C** (single-phase 200-240 VAC) indicating the power supply input is entered where the box □ is located within the product name.

Orientalmotor

These products are manufactured at plants certified with the international standards **ISO 9001** (for quality assurance) and **ISO 14001** (for systems of environmental management).

Specifications are subject to change without notice. This catalogue was published in June 2016.

ORIENTAL MOTOR (EUROPA) GmbH

www.orientalmotor.de

European Headquarters

Schiesstraße 74

40549 Düsseldorf, Germany

Tel: 0211-520 670 Fax: 0211-520 670 99



ORIENTAL MOTOR (UK) LTD.

www.oriental-motor.co.uk

UK Headquarters

Unit 5, Faraday Office Park,

Rankine Road, Basingstoke,

Hampshire RG24 8AH, U.K.

Tel: 01256-347 090 Fax: 01256-347 099



ORIENTAL MOTOR ITALIA s.r.l.

www.orientalmotor.it

Italy Headquarters

Via A. De Gasperi, 85

20017 Mazzo di Rho (MI), Italy

Tel: 02-939 063 46 Fax: 02-939 063 48



ORIENTAL MOTOR SWITZERLAND AG

www.orientalmotor.ch

Switzerland Headquarters

Badenerstraße 13

5200 Brugg AG, Switzerland

Tel: 056-560 504 5 Fax: 056-560 504 7



ORIENTAL MOTOR (FRANCE) SARL

www.orientalmotor.fr

France Headquarters

56, Rue des Hautes Pâtures

92000 Nanterre, France

Tel: 01-478 697 50 Fax: 01-478 245 16



ORIENTAL MOTOR CO., LTD.

www.orientalmotor.co.jp

Headquarters

4-8-1 Higashiueno

Taito-ku, Tokyo 110-8536, Japan

Tel: 03-674 403 61 Fax: 03-582 625 76



Other countries: www.orientalmotor.eu

Customer Center (Support in German & English)

00800-22 55 66 22*
CA LL OM CC

Mon-Thu: 08:00 - 17:30 CET Friday: 08:00 - 16:00 CET

* Free Call Europe

info@orientalmotor.de

For more information please contact: