

## Hollow Rotary Actuator **DGII Series**

**CFLEX** Built-In Controller Type  
Pulse Input Type

The new **DGII** Series uses the highly efficient and energy saving  **$\alpha$ STEP AR** Series as the motor of the hollow rotary actuator. In addition to the pulse input type, a highly functional built-in controller type that supports and increases system configuration flexibility is also available.



Hollow Rotary Actuator

# DGII Series

**Hollow rotary actuators are now even easier to use.**

In the **DGII** Series, an  **$\alpha$ STEP AR** Series stepping motor and driver package is used on a large diameter hollow rotary actuator.

Functionality for easier control of the rotary actuator mechanism is provided along with better connectivity with switches, PLC, touch panels or FA networks.

Oriental Motor has responded to customer feedback regarding conventional models to create a new actuator that is easier to use.

## ■ **DGII** Series Renewed Appeal

### High Efficiency and Energy Saving

A closed loop  **$\alpha$ STEP AR** Series stepping motor and driver package has been adopted as the motor. This creates a more efficient and energy saving product compared with conventional models.

### High Function Driver Increases System Configuration Flexibility

A system common with the **AR** Series is now used for control, and functions for easier use of the actuator have been added.

Both a built-in controller type driver that can be connected to I/O, Modbus (RTU) and FA networks as well as a pulse input type driver are available.

Flexibility for connecting with host systems has also been increased.

### What is **FLEX**?

FLEX **FLEX** is a generic name of the products which support Industrial Network control via I/O, Modbus (RTU) control and network converter. FLEX products enable easy connection, easy control and reduce the complexity of system configuration.



## ■ Same Actuator Excellence as Conventional Models

### Large-Diameter Hollow Output Table

Frame size □60 mm □85 mm □130 mm □200 mm

### High Torque and High Rigidity

### Direct Coupling Possible

### High Accuracy and Quick Positioning

## Contents

Actuator Features .....	p. 4
Lineup .....	p. 5
Motor Features .....	p. 6
Driver Features .....	p. 7
How to Read Specifications Table .....	p. 11
System Configuration .....	p. 12
Product Line .....	p. 14
Specifications and Characteristics .....	p. 15
Dimensions .....	p. 21
Connection and Operation...	p. 26
Combination List .....	p. 40
Accessories .....	p. 41



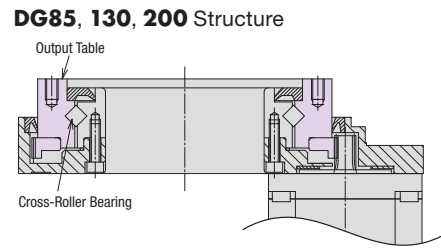
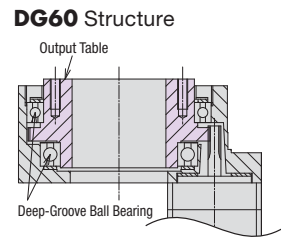
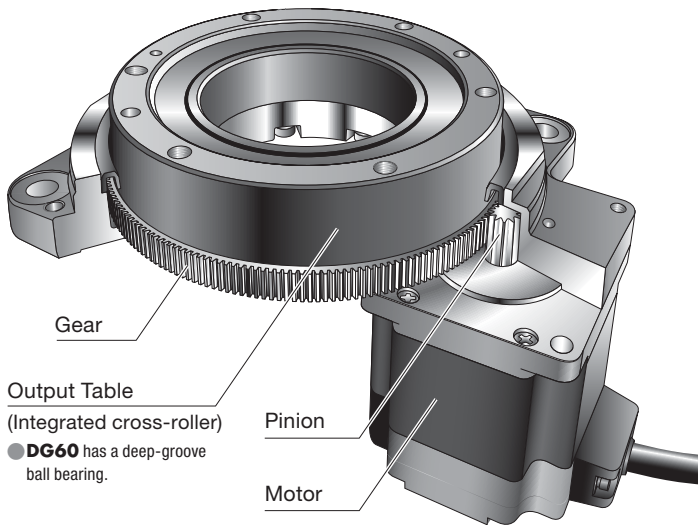

## Actuator with High Strength, Accuracy and Reliability

### High Power and High Rigidity

The hollow output table is integrated with a high rigidity cross-roller bearing\*. This structure improves permissible thrust load and moment load while maintaining high torque.

\*Excludes the **DG60**

#### <Rigidity>

The output table uses a cross-roller bearing (85, 130, and 200 mm frame size) or 2 deep-groove ball bearings (60 mm frame size). The permissible moment load increases as the frame size increases, but the displacement caused by the moment load decreases.

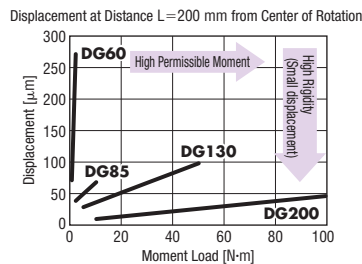
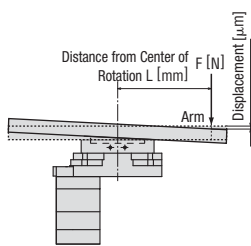

### Direct Coupling for Higher Reliability

Equipment tables and arms can be installed directly on the output table. This saves you the hassle and cost of designing an installation mechanism, arranging necessary mechanism parts, adjusting the belt tension, etc., when mechanical components such as a belt and pulley are used for installation.

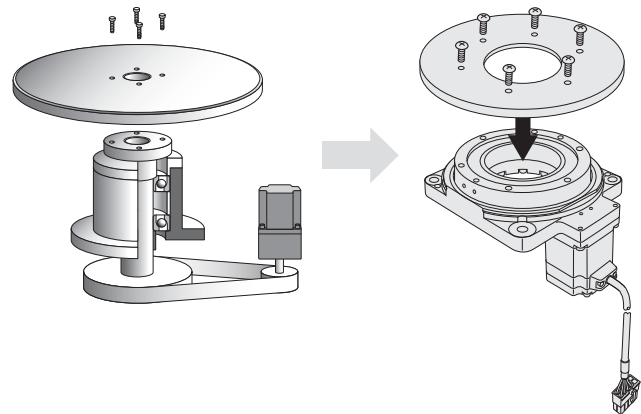

### High Positioning Accuracy with Non-Backlash

- Non-Backlash
- Repetitive Positioning Accuracy  $\pm 15$  sec
- Lost Motion 2 arc minutes

**Note** The repetitive positioning accuracy is measured at a constant temperature (normal temperature) under a constant load.

### Large-Diameter, Hollow Output Table Makes Simple Wiring and Piping Possible

The large diameter hollow hole (through-hole) helps reduce the complexity of wiring and piping, thus simplifying your equipment design.

	Frame Size mm	Diameter of Hollow Section mm
<b>DG60</b>	60	$\phi 28$
<b>DG85</b>	85	$\phi 33$
<b>DG130</b>	130	$\phi 62$
<b>DG200</b>	200	$\phi 100$

Example: **DG200**

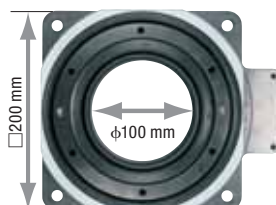

### "Home Sensor Set" is Available as an Accessory

Since the sensor set comes with all the parts required for the return-to-home operation, you will spend less time designing, fabricating and procuring parts related to sensor installation.

#### DG130 Sensor Installation Example

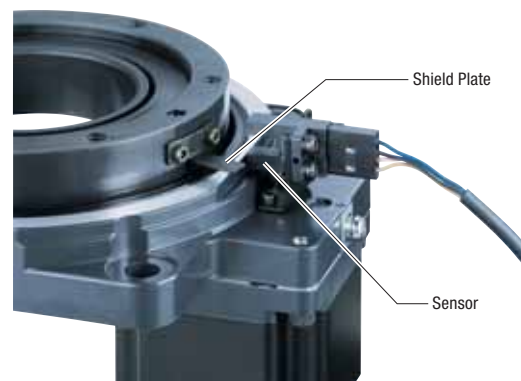

## Application

● Applications Subject to Changing Load Inertia

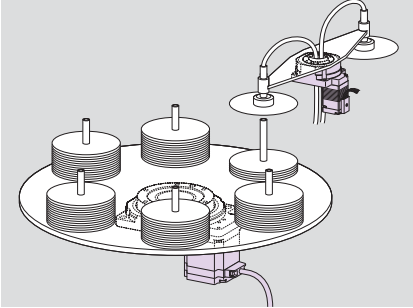

● Applications Where a Moment Load is Applied

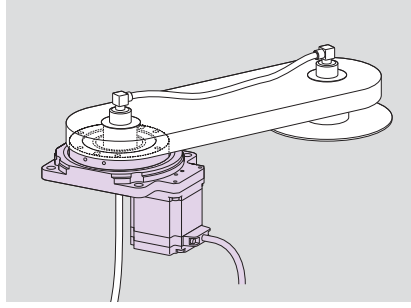

● Optical Applications Using the Hollow Hole

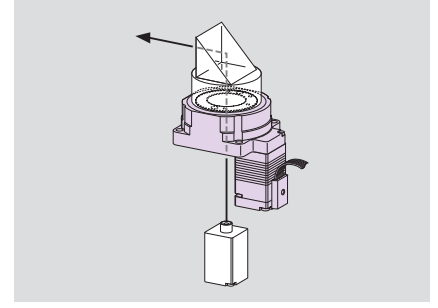

● High Positioning Accuracy Applications

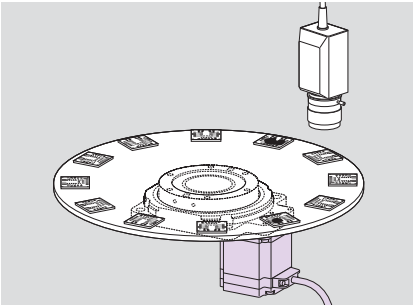

● High Positioning Accuracy Applications Using the Hollow Hole

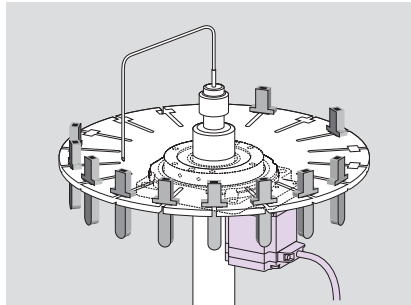

● Air Adsorption Applications Using the Hollow Hole

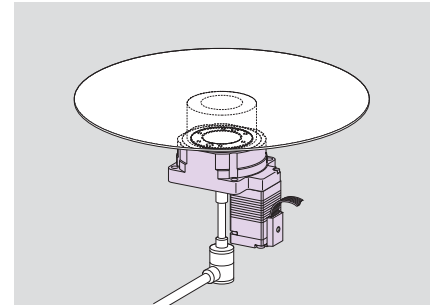

## Lineup

Product	Motor Series	Electro-magnetic Brake	Driver	Power Supply Voltage	Diameter of Hollow Section [mm]	Permissible Torque [N·m]	Permissible Moment Load [N·m]				Permissible Thrust Load [N]					
							20	40	60	80	1000	2000	3000			
<b>DG60</b> 60 mm 	AR	—	Built-in Controller	24 VDC	φ28	0.9	2							100		
			Pulse Input	24 VDC												
<b>DG85</b> 85 mm 	AR	—	Built-in Controller	Single-Phase 100-120 VAC Single-Phase 200-240 VAC	φ33	2.8	10							500		
			Pulse Input	Single-Phase 100-115 VAC Single-Phase 200-230 VAC Three-Phase 200-230 VAC												
<b>DG130</b> 130 mm 	AR	●	Built-in Controller	Single-Phase 100-120 VAC Single-Phase 200-240 VAC	φ62	12	50							2000		
			Pulse Input	Single-Phase 100-115 VAC Single-Phase 200-230 VAC Three-Phase 200-230 VAC												
<b>DG200</b> 200 mm 	AR	●	Built-in Controller	Single-Phase 100-120 VAC Single-Phase 200-240 VAC	φ100	50	100							4000		
			Pulse Input	Single-Phase 100-115 VAC Single-Phase 200-230 VAC Three-Phase 200-230 VAC												

## Excellent Characteristics Unique to Stepping Motors

### User-Friendly and Easy, Highly Accurate Positioning

Stepping motors provide convenient means to ensure highly accurate positioning because they synchronize themselves with commands without requiring feedback.

### High response

The motor operates synchronously with pulse commands to achieve high response.

There's no time lag in operation following a pulse command.

## High Reliability Due to Oriental Motor's Unique Closed Loop Control

### Adoption of a Rotor Position Detection Sensor (Resolver)

- Because the sensor is compact and slim, the overall length of the motor has been reduced.
- Performance such as heat resistance and vibration resistance is better than with regular optical encoders.
- Because an encoder cable is not necessary, the motor and driver can be connected with just 1 cable.

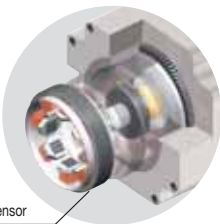

Rotor Position Detection Sensor

### Continues Operation Even with Sudden Load Fluctuation and Sudden Acceleration

Operates synchronously with commands using open loop control during normal conditions. In an overload condition, changes immediately to closed loop control to correct the position.

### Alarm Signal Output in Case of Abnormality

If an overload is applied continuously, an alarm signal is output. When the positioning is complete, an end signal is output. This ensures the same level of reliability achieved by a servo motor.

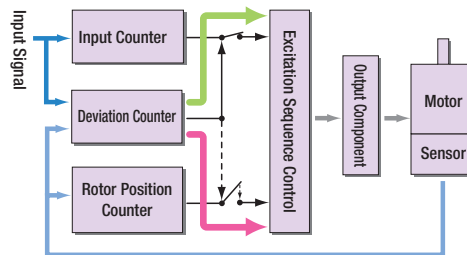

**Normal**

- Motor runs in open loop mode like a stepping motor.

**Overload Condition**

The closed loop mode is engaged to maintain the positioning operation.

## Continuous Operation Possible Due to Lower Heat Generation from Higher Efficiency

### Lower Heat Generation

Heat generation by the motor has been significantly reduced through higher efficiency.

- Temperature Distribution by Thermography

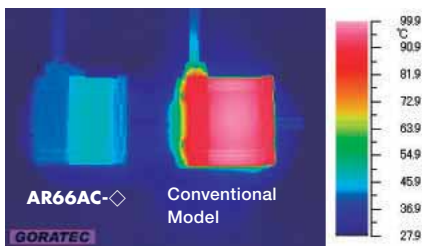

Comparison under same conditions.

- Motor Surface Temperature during Same Operation Conditions

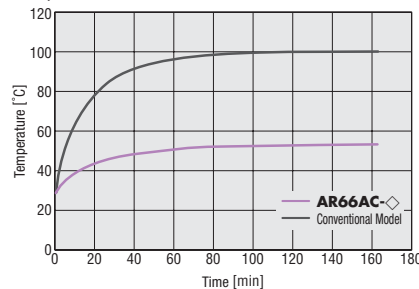

### Power Consumption: 66% Less Than Conventional Model due to Energy-Saving Features\*

- Power Consumption

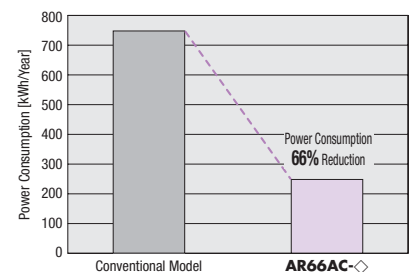

### CO<sub>2</sub> Emissions: 66% Less Than Conventional Model\* (Oriental Motor comparison)

\* Speed: 1000 r/min, Load Factor: 50%  
 Operating Time: 24 hours of operation (70% operating, 25% standing by, 5% standstill), 365 days/year

## 2 Driver Types Selectable by System Configuration

You can select from 2 driver types for the **DGII** Series, depending on your host system.

### Built-in Controller Type **C-FLEX**

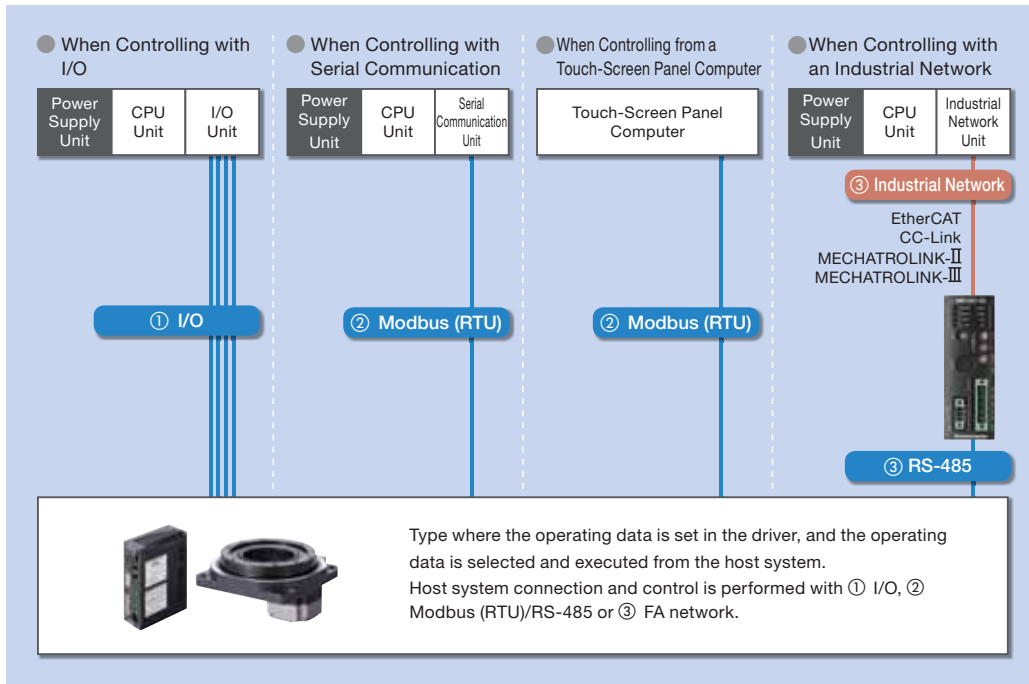

### Pulse Input Type

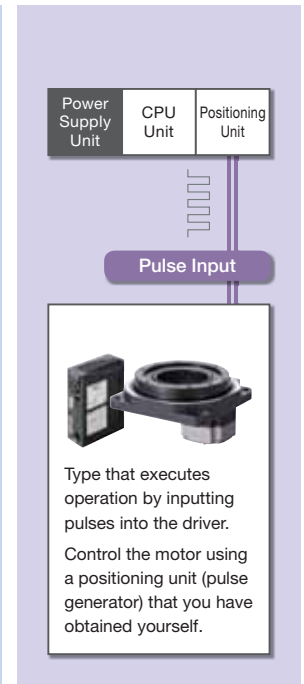

## How to Connect a Built-In Controller Type

### ① I/O

Because the positioning unit (pulse generator) function is built in to the driver, you can build an operation system using I/O by directly connecting to a switch box or PLC. Because a positioning unit is not necessary on the PLC side, space is saved and the system is simplified.

#### ● Example of Using a Switch Box

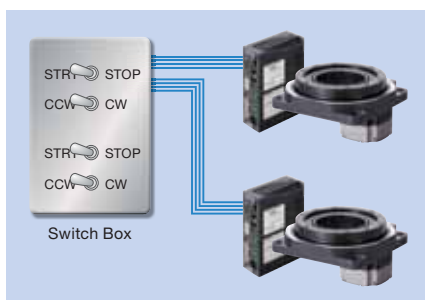

Because operating data is set in the driver, the actuator can be started and stopped simply by connecting a switch you have on hand. Control can be performed easily without using PLC.

#### ● Example of Using PLC

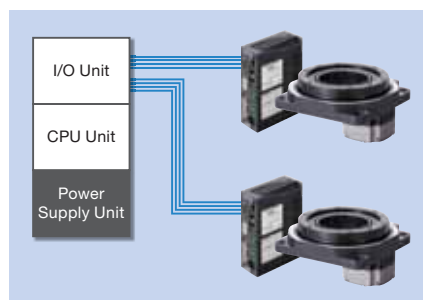

When using PLC, you can build an operation system by connecting directly to an I/O unit. Because a positioning unit is not necessary on the PLC side, space is saved and the system is simplified.

#### ● Example of Using PLC and a Touch Panel

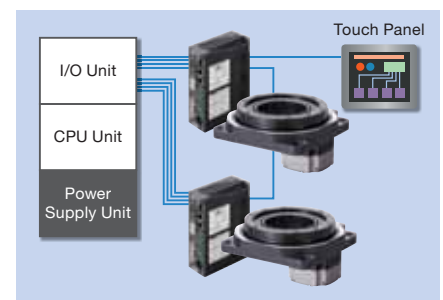

Normally, the actuator is started and stopped with I/O. Changing the operating data settings and displaying the monitors and alarms is performed with the touch panel using Modbus (RTU) communication. When there is a lot of setup work, changes can be easily performed on the touch panel, and the burden of creating ladders is reduced.

### ② Modbus (RTU)/RS-485

Operating data and parameters can be set and operation commands can be input using RS-485 communication. Up to 31 drivers can be connected to each serial communication unit. Also, there is a function that enables the simultaneous start of multiple axes. The protocol supports Modbus (RTU), enabling connection with devices such as touch-screen panel computers and PCs.

## Built-In Controller Type

Because the driver has the information necessary for actuator operation, the burden on the host PLC is reduced. The system configuration when using multi-axis control has been simplified.

Settings are configured using a control module (sold separately), data setting software or RS-485 communication.

### Operation Types

In the built-in controller type, the operating speed and traveling amount of the actuator are set with operating data, and operation is performed according to the selected operating data.

**Basic Setting (Factory Setting)**

Actuator



Driver



Connection Cable

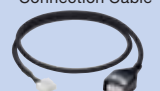

+

**Operation Data Setting Parameter Changing**

Control Module (OPX-2A)



or



Data Setting Software (MEXE02)

● Settings using RS-485 communication are also available.

Data Setting

Test Operation

Alarm History

Parameter Changing

Monitoring

Data Copying

Item		Content	
Common	Control Method	I/O Control	
		RS-485 Communication	Network converter connection Modbus RTU protocol connection
	Position Command Input	Setting with operating data number	Command range for each point: -8388608 to 8388607 [step] (Setting Unit: 1 [step])
	Speed Command Input	Setting with operating data number	Command Range: 0 to 1000000 [Hz] (Setting Unit: 1 [Hz])
	Acceleration/Deceleration Command Input	Set with the operating data number or parameter. You can select acceleration/deceleration rate [ms/kHz] or acceleration/deceleration time [sec]. Command Range: 0.001 to 1000.000 [ms/kHz] (Setting Unit: 0.001 [ms/kHz]) 0.001 to 1000.000 [sec] (Setting Unit: 0.001 [sec])	
Acceleration/Deceleration Processing	Velocity filter, movement average filter		
Return-To-Home Operation	Return-to-Home Modes	2-Sensor Mode	A return-to-home operation that uses a limit sensor (+LS, -LS).
		3-Sensor Mode	A return-to-home operation that uses a limit sensor and home sensor.
		Position Preset	A function where P-preset is input at the desired position to confirm the home position. You can set the home position to the desired value.
Positioning Operation	Number of Positioning Points	64 points (No. 0 to 63)	
		Operating Modes	Incremental mode (Relative positioning)
	Operation Functions		Independent Operation
		Linked Operation	A multistep speed-change positioning operation that is linked with operating data.
		Linked Operation 2	A positioning operation with a timer that is linked with operating data. The timer (dwell time) can be set from 0 to 50.000 [sec]. (Setting Unit: 0.001 [sec])
	Start Methods	Operating Data Selection Method	Starts the positioning operation when Start is input after selecting M0 to M5.
Direct Method (Direct positioning)		Starts the positioning operation with the operating data number set in the parameters when MS0 to MS5 is input. Starts the positioning operation.	
Sequential Method (Sequential positioning)		Starts the positioning operation in sequence from operating data No. 0 each time SSTART is input.	
Continuous Operation	Number of Speed Points	64 points (No. 0 to 63)	
	Speed Change Method	Change the operating data number.	
Other Operations	JOG Operation	Execute regular feed by inputting +JOG or -JOG.	
	Automatic Return Operation	When the motor position is moved by an external force while the motor is in a non-excitation state, it automatically returns to the position where it originally stopped.	
Absolute Backup	You can build an absolute system by using a battery (accessory).		

● Push-motion operation cannot be used with this product.

### Positioning Operation

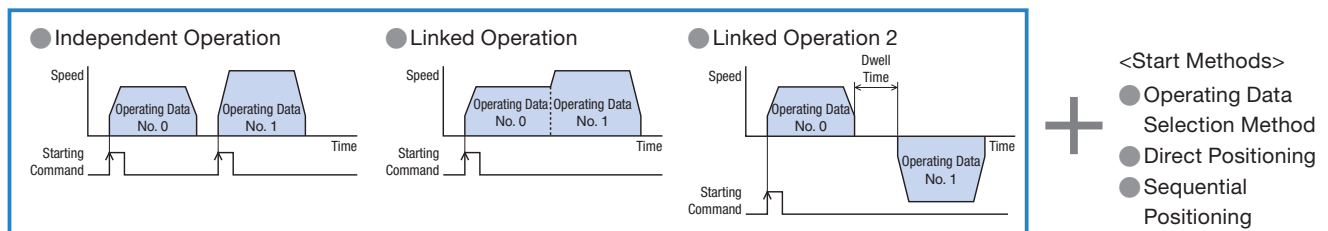



## Return-To-Home Operation

### ● 2-Sensor Mode

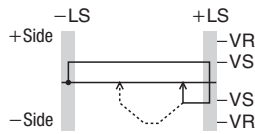

### ● 3-Sensor Mode

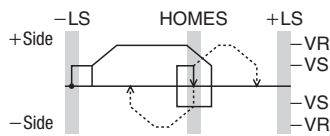

### ● Position Preset

## Continuous Operation

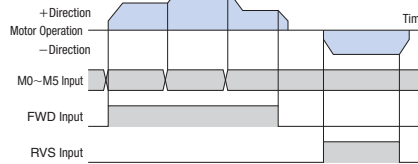

## Other Operations

### ● JOG Operation (Test operation)

### ● Automatic Return Operation

- Equipped with a sequence for return-to-home operation that reduces the burden of the host master and the hassle of creating a ladder.

## Main Function

Function	Content
Motor Resolution Setting Function*1	<p>The motor resolution can be changed by the driver without the mechanically operated speed reduction mechanism. A desired setting can be made from 100 to 10000 [P/R].</p> <p>How to obtain the resolution on the actuator</p> $1000 \times \frac{\text{Electronic gear B}}{\text{Electronic gear A (Gear ratio)}} \times 18 \quad [\text{P/R}]$
Group Send Function (RS-485 communication)	<p>You can configure a group of multiple axes connected using RS-485 communication, and send commands by group. You can also perform simultaneous start and simultaneous operation for multiple axes.</p>
Round Function	<p>When the command position is outside the setting value of the "round setting range" parameter, this function returns the command position and multiple rotation data to 0. Because the multiple rotation data is also returned to 0, you can perform position control even for continuous rotation operations in the same direction that use the absolute backup system.</p> <ul style="list-style-type: none"> <li>● When building an absolute system, the accessory (sold separately) battery is necessary.</li> </ul>
Hardware Overtravel	This function stops the actuator when exceeding the mechanical limit.
Software Overtravel	This function stops the actuator when exceeding the limit set by the software. Depending on the setting, an alarm can also be output without stopping.
Stop Input (External stop)	This function forcibly stops operation when there is an abnormality or other issue. You can select instantaneous stop, deceleration stop, or all windings off (actuator holding force is off) as the stopping method.
Alarm Code Output	You can output alarm codes that are occurring.
Alarm History	Even if the power is turned off, up to 10 alarms that have occurred can be stored. This can be used for troubleshooting.
Velocity Filter	This is used to make adjustments when a smooth start/stop or smooth motion at low speed operation is required. Even for sudden operation command changes, this function controls the speed changes of the actuator to prevent them from becoming too large.
Teaching Function*1	You can perform teaching. Move the load to the target position, and store the position data at this time as the positioning data.
I/O Monitoring*1	You can check the ON/OFF status of the I/O signals.
Waveform Monitoring*2	You can check the operating speed and I/O signals as a waveform.

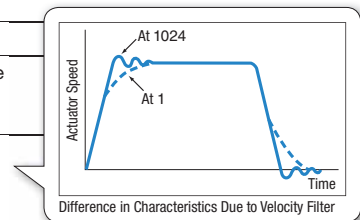
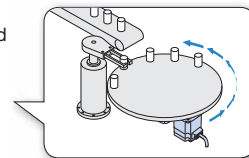
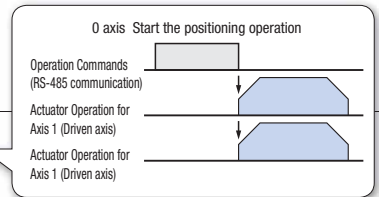

● The **MEXE02** data setting software can be downloaded from the Oriental Motor website. Oriental Motor can also provide a CD-ROM. For details, please contact the nearest Oriental Motor sales office.

\*1 Can be performed with the separately-sold control module **(OPX-2A)** or data setting software **(MEXE02)**.

\*2 Can be performed with the data setting software **(MEXE02)**.

## Pulse Input Type

You can use the separately-sold control module and data setting software to perform operations according to your needs, such as changing the parameters, displaying the alarm history, and performing various types of monitoring.

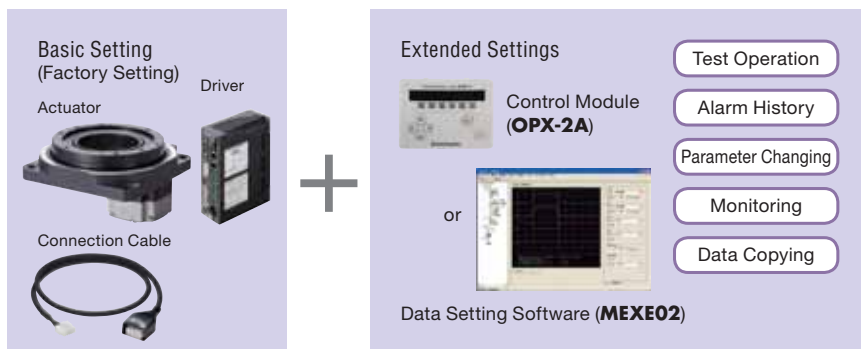

### Main Additional Functions Available with Extended Settings

Item	Overview	Basic Setting	Extended Settings
Selection of Pulse Input Mode	You can select the 1-pulse input or 2-pulse input (negative logic) mode.	●	●
	In addition to the normal settings, you can set phase difference input. · 1-pulse input mode (positive logic/negative logic) · 2-pulse input mode (positive logic/negative logic) · Phase difference input (1-multiplication/2-multiplication/4-multiplication)	—	●
Resolution Setting	You can select the resolution with the function switches (D0, D1, CS0, CS1).	●	●
	You can change the value of the electronic gear corresponding to each function switch (D0, D1, CS0, CS1).	—	●
Running Current Setting	You can change the running current setting with the current setting switch (CURRENT).	●	●
	You can change the value corresponding to each of 0 to F (16 levels) for the current setting switch (CURRENT).	—	●
Standstill Current Ratio Setting	You can set the ratio of the standstill current relative to the running current.	—	●
Motor Rotational Coordinates Setting	You can set the rotational coordinates for the motor.	—	●
All Windings On Signal (C-ON input)	The input signal for the excitation of the motor.	●	●
	You can set the C-ON input logic for when the power supply is input.	—	●
Return to Excitation Position Operation during All Windings On Enable/Disable	You can set whether or not to return to the excitation position (deviation 0 position) during all windings on.	—	●
Alarm Code Signal Enable/Disable	Set to output the code when an alarm occurs.	—	●
End Output Signal Range Setting	You can change the End output signal range.	—	●
End Output Signal Offset	You can offset the End output signal value.	—	●
A-/B-Phase Output	You can use for motor position verification.	●	●
Timing Output Signal	This is output each time the motor rotates 7.2° (0.4° for the output table).	●	●
Velocity Filter Setting	Applies a filter to the operation command to control the motor action.	●	●
	You can change the value corresponding to each of 0 to F (16 levels) for the setting switch.	—	●
Vibration Suppression Function for Normal Mode	You can set to suppress resonant vibration during rotation.	—	●
	You can set to suppress vibration during acceleration, deceleration and stopping.	—	●
Gain Adjustment for Current Control Mode*	Adjusts the position and speed loop gain.	—	●
	Adjusts the speed integration time constant.	—	●
	Sets the damping control vibration frequency.	—	●
	Sets whether to enable or disable damping control.	—	●
Selection of Motor Excitation Position at Power On	You can select the motor excitation position for when the power is turned on.	—	●
Control Module Setting	You can select whether to use symbols or an absolute value display for the speed display of the control module.	—	●
	You can set the geared motor gear ratio for the speed monitor. (The gear ratio for the <b>DGII</b> Series is 1:18)	—	●

● The **MEXE02** data setting software can be downloaded from the Oriental Motor website. Oriental Motor can also provide a CD-ROM. For details, please contact the nearest Oriental Motor sales office.

\*Except when you want to further reduce heat generation or noise, using normal mode is recommended.

# How to Read Specifications Table

## Built-In Controller Type

Product Name	Frame Size		85 mm	130 mm
	Single-Phase 100-120 VAC	Single Shaft	<b>DG85R-ARAAD2-◇</b>	<b>DG130R-ARAAD2-◇</b>
		Double Shaft	<b>DG85R-ARBAD2-◇</b>	<b>DG130R-ARBAD2-◇</b>
		Electromagnetic Brake Type	—	<b>DG130R-ARMAD2-◇</b>
Motor Type		<b>αSTEP</b> Motor for <b>AR</b> Series		
①	Output Table Supporting Bearing		Cross-Roller Bearing	
②	Permissible Torque		N·m	2.8
③	Inertia		J: kg·m <sup>2</sup>	22092×10 <sup>-7</sup>
④	Permissible Speed		r/min	200
Gear Ratio		18		
⑤	Power ON		N·m	1.8
⑥	Power OFF		N·m	0
⑦	Electromagnetic Brake		N·m	—
⑧	Resolution		The resolution can be set from 1800 to 180000 P/R by using parameters.	
Voltage and Frequency		Single-phase 100-120 VAC, single-phase 200-240 VAC -15 to +6% 50/60 Hz		
⑨	Power-Supply Input		24 VDC	—
Input Current		A Single-Phase 100-120 VAC	2.4	3.6
		Single-Phase 200-240 VAC	1.5	2.3
Control Power Supply		24 VDC±5% 0.5A		
Electromagnetic Brake Power-Supply Input		—		
⑩	Repetitive positioning accuracy		sec	±15 (±0.004°)
⑪	Lost Motion		arc minute (degrees)	2 (0.033°)
⑫	Angular Transmission Accuracy		arc minute (degrees)	4 (0.067°)
⑬	Permissible Thrust Load		N	500
⑭	Permissible Moment Load		N·m	10
⑮	Runout of Output Table Surface		mm	0.015
⑯	Runout of Output Table Inner (Outer) Diameter		mm	0.015
⑰	Parallelism of Output Table		mm	0.030
⑱	Degree of Protection		Single Shaft, Electromagnetic Brake Type: IP40 (IP20 for motor connector) Double Shaft: IP20	
Mass of Actuator Unit		kg	1.17	2.65 [2.95]

- ① Output Table Supporting Bearing  
This is the type of the bearing used for the output table.
- ② Permissible Torque  
This is the limit of mechanical strength of the speed reduction mechanism. Make sure that the applied torque, including the acceleration torque and load fluctuation, does not exceed the permissible torque.
- ③ Inertia  
This is the total sum of the rotor inertial moment of the motor and the inertial moment of the speed reduction mechanism converted to a moment on the output table.
- ④ Permissible Speed  
This is the output table speed that can be tolerated by the mechanical strength of the speed reduction mechanism.
- ⑤ Maximum Holding Torque (Power supply ON)  
This is the maximum torque with which to hold the output table in position if it stops while the power is still on.
- ⑥ Maximum Holding Torque (Power supply OFF)  
This is the maximum torque with which to hold the output table in position if it stops after the power has been cut off.
- ⑦ Maximum Holding Torque (Electromagnetic brake)  
This is the maximum torque (with electromagnetic brake only) with which to hold the output table in position using an electromagnetic brake when it stops.
- ⑧ Resolution  
Number of pulses needed to rotate the output table by one rotation.
- ⑨ Power-Supply Input  
The current value of the power-supply input is the max. input current value for the driver. (The input current varies according to the rotation speed.)
- ⑩ Repetitive Positioning Accuracy  
This is a value indicating the degree of error that generates when positioning is performed repeatedly to the same position in the same direction.

- ⑪ Lost Motion  
This is the difference in stopped angles achieved when the output table is positioned to the same position in the forward and reverse directions.
- ⑫ Angular Transmission Accuracy  
This is the difference between the theoretical rotation angle of the output table as calculated from the input pulse counter, and the actual rotation angle.
- ⑬ Permissible Thrust Load  
This is the permissible value of thrust load applied to the output table in the axial direction.
- ⑭ Permissible Moment Load  
When a load is applied to a position away from the center of the output table, the output table receives a tilting force. The permissible moment load refers to the permissible value of moment load calculated by the eccentricity from the center by the applied load.
- ⑮ Runout of Output Table Surface  
This is the max. value of runout of the installation surface of the output table when the output table is rotated under no load.
- ⑯ Runout of Output Table Inner (Outer) Diameter  
This is the max. value of runout of the inner diameter or outer diameter of the table when the output table is rotated under no load.
- ⑰ Parallelism of Output Table  
This is the inclination of the installation surface of the output table compared with the actuator installation surface on the equipment side.
- ⑱ Degree of Protection  
Based on IEC60529 and EN60034-5 (=IEC60034-5), dust-resistance and waterproofing regarding the degree of protection of the device is classified using a grade.

## System Configuration

### Built-In Controller, AC Power-Supply Input Electromagnetic Brake Type **C-FLEX**

An example of a configuration using I/O control or RS-485 communication is shown below.

\*1 Not supplied.

\*2 To be provided by the customer as necessary.

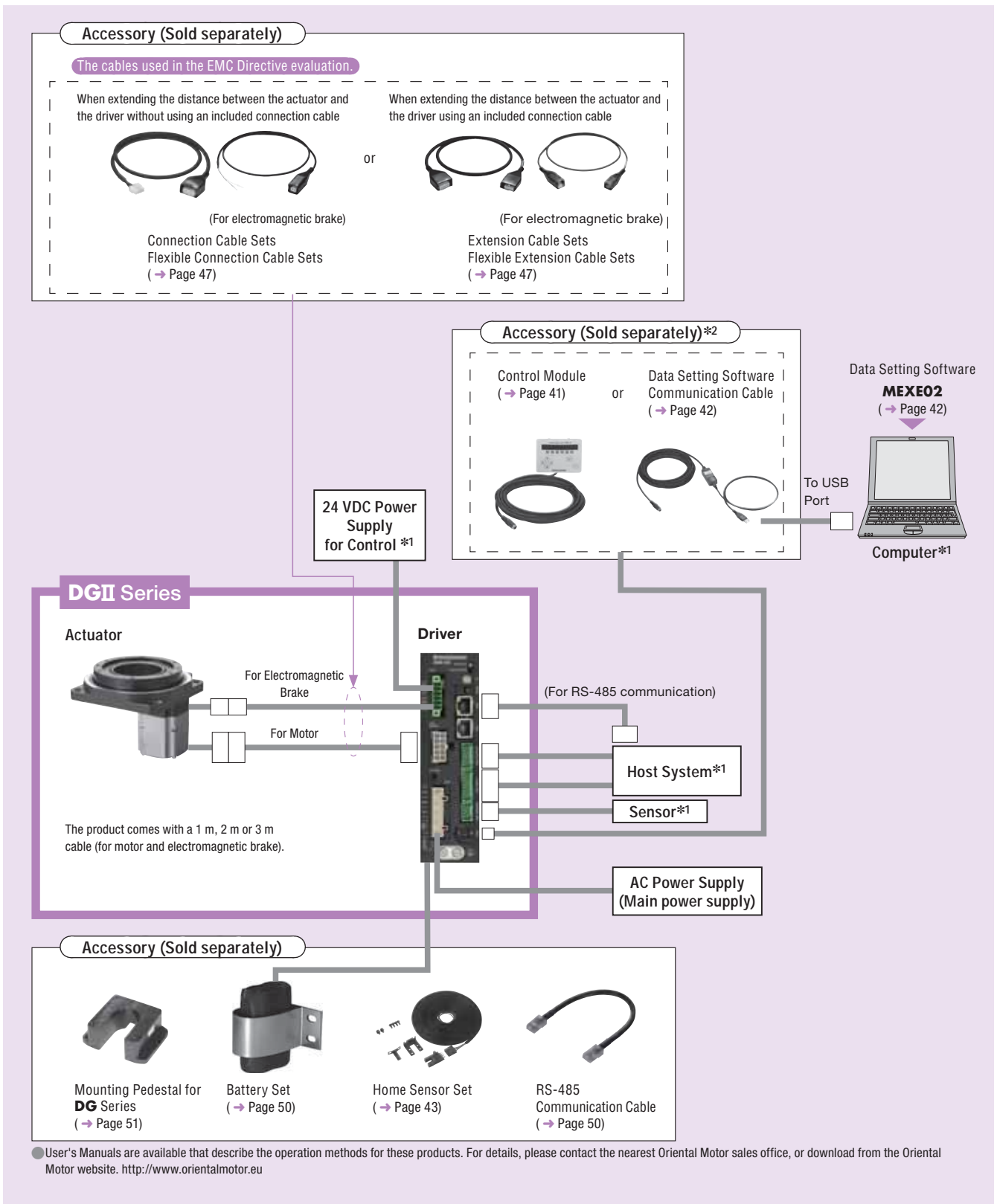

### System Configuration Example



● The system configuration shown above is an example. Other combinations are available.

## Pulse Input, AC Power-Supply Input Electromagnetic Brake Type

An example of a single-axis system configuration with the **SCX11** controller is shown below.

\*Not supplied.

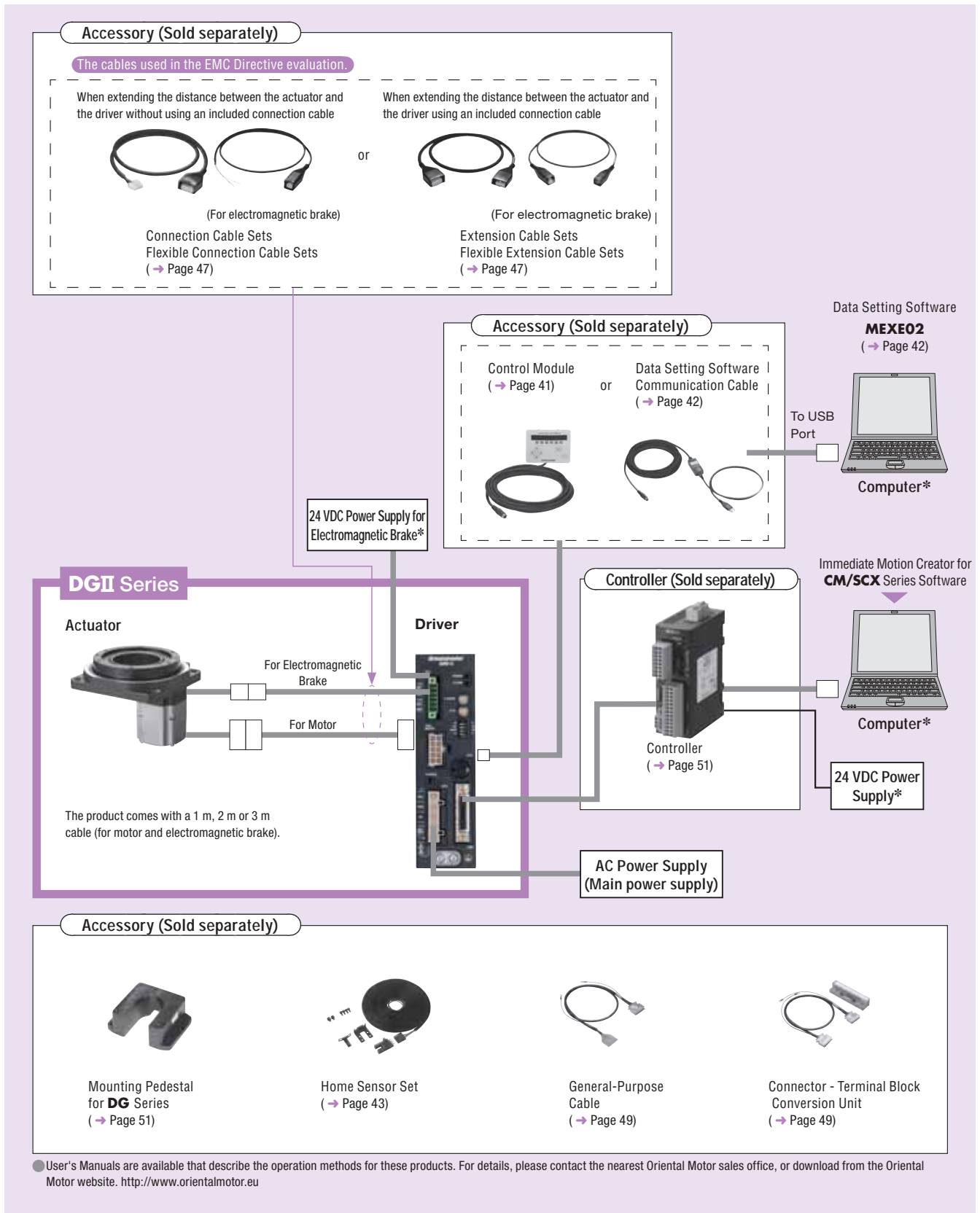

### System Configuration Example

<b>DGII Series</b>	+	Sold Separately		
		Controller	Mounting Pedestal for <b>DG</b> Series	Home Sensor Set
<b>DG130R-ARMC2-1</b>		<b>SCX11</b>	<b>MDG130A</b>	<b>PADG-SBY</b>

● The system configuration shown above is an example. Other combinations are available.

## Product Number Code

# DG 130 R - AR A C D 2 - 1

① ② ③ ④ ⑤ ⑥ ⑦ ⑧ ⑨

①	Series Name <b>DG: DGII Series</b>
②	Frame Size <b>60:</b> 60 mm <b>85:</b> 85 mm <b>130:</b> 130 mm <b>200:</b> 200 mm
③	Output Table Supporting Bearing Type Blank: Deep-Groove Ball Bearing <b>R</b> : Cross-Roller Bearing
④	Motor Type <b>AR:</b> Motor for <b>AR</b> Series
⑤	Motor Shaft Configuration <b>A:</b> Single Shaft <b>B:</b> Double Shaft <b>M:</b> Electromagnetic Brake Type
⑥	Power-Supply Input Built-In Controller Type <b>A:</b> Single-Phase 100-120 VAC <b>C:</b> Single-Phase 200-240 VAC <b>K:</b> 24 VDC Pulse Input Type <b>A:</b> Single-Phase 100-115 VAC <b>C:</b> Single-Phase 200-230 VAC <b>S:</b> Three-Phase 200-230 VAC <b>K:</b> 24 VDC
⑦	Driver Blank: Pulse Input Type <b>D:</b> Built-In Controller Type
⑧	Reference Number: —
⑨	Length of Cables (Included) <b>1:</b> 1 m <b>2:</b> 2 m <b>3:</b> 3 m

## Product Line

### Built-In Controller Type

#### ◇ DC Power-Supply Input

24 VDC
Product Name
<b>DG60-ARAKD2-◇</b>
<b>DG60-ARBKD2-◇</b>

#### ◇ AC Power-Supply Input

Single-Phase 100-120 VAC	Single-Phase 200-240 VAC
Product Name	Product Name
<b>DG85R-ARAAD2-◇</b>	<b>DG85R-ARACD2-◇</b>
<b>DG85R-ARBAD2-◇</b>	<b>DG85R-ARBCD2-◇</b>
<b>DG130R-ARAAD2-◇</b>	<b>DG130R-ARACD2-◇</b>
<b>DG130R-ARBAD2-◇</b>	<b>DG130R-ARBCD2-◇</b>
<b>DG130R-ARMAD2-◇</b>	<b>DG130R-ARMCD2-◇</b>
<b>DG200R-ARAAD2-◇</b>	<b>DG200R-ARACD2-◇</b>
<b>DG200R-ARBAD2-◇</b>	<b>DG200R-ARBCD2-◇</b>
<b>DG200R-ARMAD2-◇</b>	<b>DG200R-ARMCD2-◇</b>

### Pulse Input Type

#### ◇ DC Power-Supply Input

24 VDC
Product Name
<b>DG60-ARAK2-◇</b>
<b>DG60-ARBK2-◇</b>

#### ◇ AC Power-Supply Input

Single-Phase 100-115 VAC	Single-Phase 200-230 VAC	Three-Phase 200-230 VAC
Product Name	Product Name	Product Name
<b>DG85R-ARAA2-◇</b>	<b>DG85R-ARAC2-◇</b>	<b>DG85R-ARAS2-◇</b>
<b>DG85R-ARBA2-◇</b>	<b>DG85R-ARBC2-◇</b>	<b>DG85R-ARBS2-◇</b>
<b>DG130R-ARAA2-◇</b>	<b>DG130R-ARAC2-◇</b>	<b>DG130R-ARAS2-◇</b>
<b>DG130R-ARBA2-◇</b>	<b>DG130R-ARBC2-◇</b>	<b>DG130R-ARBS2-◇</b>
<b>DG130R-ARMA2-◇</b>	<b>DG130R-ARMC2-◇</b>	<b>DG130R-ARMS2-◇</b>
<b>DG200R-ARAA2-◇</b>	<b>DG200R-ARAC2-◇</b>	<b>DG200R-ARAS2-◇</b>
<b>DG200R-ARBA2-◇</b>	<b>DG200R-ARBC2-◇</b>	<b>DG200R-ARBS2-◇</b>
<b>DG200R-ARMA2-◇</b>	<b>DG200R-ARMC2-◇</b>	<b>DG200R-ARMS2-◇</b>

● A number indicating the desired length of **1** (1 m), **2** (2 m) or **3** (3 m) for the cable included with the product is entered where the box ◇ is located within the product name.  
Select a desired cable length from 1 m, 2 m and 3 m.

# Specifications

Built-In Controller Type (RoHS) (FLEX)



Product Name	Frame Size		60 mm	85 mm	130 mm	200 mm
	24 VDC Single-Phase 100-120 VAC Single-Phase 200-240 VAC	Single Shaft		DG60-ARAKD2-◇	—	—
Double Shaft*1			DG60-ARBKD2-◇	—	—	—
Single Shaft			—	DG85R-ARAAD2-◇	DG130R-ARAAD2-◇	DG200R-ARAAD2-◇
Double Shaft*1			—	DG85R-ARBAD2-◇	DG130R-ARBAD2-◇	DG200R-ARBAD2-◇
Electromagnetic Brake Type			—	—	DG130R-ARMAD2-◇	DG200R-ARMAD2-◇
Single Shaft			—	DG85R-ARACD2-◇	DG130R-ARACD2-◇	DG200R-ARACD2-◇
Double Shaft*1			—	DG85R-ARBCD2-◇	DG130R-ARBCD2-◇	DG200R-ARBCD2-◇
	Electromagnetic Brake Type		—	—	DG130R-ARMCD2-◇	DG200R-ARMCD2-◇
Motor Type			αSTEP Motor for AR Series			
Output Table Supporting Bearing			Deep-Groove Ball Bearing		Cross-Roller Bearing	
Permissible Torque		N·m	0.9	2.8	12	50
Inertia		J: kg·m <sup>2</sup>	4324×10 <sup>-7</sup>	22092×10 <sup>-7</sup>	150620×10 <sup>-7</sup> [189500×10 <sup>-7</sup> ]*2	916400×10 <sup>-7</sup> [955280×10 <sup>-7</sup> ]*2
Permissible Speed		r/min	200			110
Gear Ratio			18			
Maximum Holding Force	Power ON	N·m	0.45	1.8	12	36 [20]*2
	Power OFF	N·m	0	0	0	0
	Electromagnetic Brake	N·m	—	—	12	20
Resolution			The resolution can be set from 1800 to 180000 P/R by using parameters.			
Voltage and Frequency			24 VDC±5%	Single-phase 100-120 VAC, single-phase 200-240 VAC -15 to +6% 50/60 Hz		
Power-Supply Input	24 VDC	A	1.3	—	—	—
	Input Current	Single-Phase 100-120 VAC	—	2.4	3.6	5.9
		Single-Phase 200-240 VAC	—	1.5	2.3	3.7
Control Power Supply			—	24 VDC±5% 0.5 A		
Electromagnetic Brake Power-Supply Input			—	—	24 VDC±5%*3 0.25 A	24 VDC±5%*3 0.25 A
Repetitive Positioning Accuracy		sec	±15 (±0.004 <sup>1</sup> )			
Lost Motion		arc minute	2 (0.033 <sup>1</sup> )			
Angular Transmission Accuracy		arc minute	4 (0.067 <sup>1</sup> )			
Permissible Thrust Load		N	100	500	2000	4000
Permissible Moment Load		N·m	2	10	50	100
Runout of Output Table Surface		mm	0.030			
Runout of Output Table Inner (Outer) Diameter		mm	0.030	0.015		0.030
Parallelism of Output Table		mm	0.050	0.030		0.050
Degree of Protection			Single Shaft, Electromagnetic Brake Type: IP40 (IP20 for motor connector) Double Shaft: IP20			
Mass of Actuator Unit		kg	0.5	1.17	2.65 [2.95]*2	9.5 [10.1]*2

● A number indicating the desired length of **1** (1 m), **2** (2 m) or **3** (3 m) for the cable included with the product is entered where the box ◇ is located within the product name.

\*1 The back shaft of the motor in the double shaft type is intended for installing a slit disk. Do not apply load torque, overhung load or thrust load to the back shaft of the motor.

\*2 The brackets [ ] indicate the specifications for the electromagnetic brake type.

\*3 If the wiring distance between the motor and driver is extended to 20 m min. using an accessory cable (sold separately), the 24 VDC±4% specification applies.

### Note

● Depending on the driving conditions, a considerable amount of heat may be generated by the motor. Be sure to keep the temperature of the motor case at approximately 100°C max.

● The repetitive positioning accuracy is measured at a constant temperature (normal temperature) under a constant load.

Lineup

Features

How to Read Specifications Table

System Configuration

Product Line

Specifications and Characteristics

Dimensions

Connection and Operation

Combination List

Accessories

Frame Size		60 mm	85 mm	130 mm	200 mm	
Product Name	24 VDC	Single Shaft	<b>DG60-ARAK2-◇</b>	–	–	
		Double Shaft*1	<b>DG60-ARBK2-◇</b>	–	–	
	Single-Phase 100-115 VAC	Single Shaft	–	<b>DG85R-ARAA2-◇</b>	<b>DG130R-ARAA2-◇</b>	<b>DG200R-ARAA2-◇</b>
		Double Shaft*1	–	<b>DG85R-ARBA2-◇</b>	<b>DG130R-ARBA2-◇</b>	<b>DG200R-ARBA2-◇</b>
		Electromagnetic Brake Type	–	–	<b>DG130R-ARMA2-◇</b>	<b>DG200R-ARMA2-◇</b>
	Single-Phase 200-230 VAC	Single Shaft	–	<b>DG85R-ARAC2-◇</b>	<b>DG130R-ARAC2-◇</b>	<b>DG200R-ARAC2-◇</b>
		Double Shaft*1	–	<b>DG85R-ARBC2-◇</b>	<b>DG130R-ARBC2-◇</b>	<b>DG200R-ARBC2-◇</b>
		Electromagnetic Brake Type	–	–	<b>DG130R-ARMC2-◇</b>	<b>DG200R-ARMC2-◇</b>
	Three-Phase 200-230 VAC	Single Shaft	–	<b>DG85R-ARAS2-◇</b>	<b>DG130R-ARAS2-◇</b>	<b>DG200R-ARAS2-◇</b>
		Double Shaft*1	–	<b>DG85R-ARBS2-◇</b>	<b>DG130R-ARBS2-◇</b>	<b>DG200R-ARBS2-◇</b>
		Electromagnetic Brake Type	–	–	<b>DG130R-ARMS2-◇</b>	<b>DG200R-ARMS2-◇</b>
	Motor Type		Motor for <b>AR</b> Series			
Output Table Supporting Bearing		Deep-Groove Ball Bearing	Cross-Roller Bearing			
Permissible Torque		N·m	0.9	2.8	12	50
Inertia		J: kg·m <sup>2</sup>	4324×10 <sup>-7</sup>	22092×10 <sup>-7</sup>	150620×10 <sup>-7</sup> [189500×10 <sup>-7</sup> ]*3	916400×10 <sup>-7</sup> [955280×10 <sup>-7</sup> ]*3
Permissible Speed		r/min	200			110
Gear Ratio			18			
Maximum Holding Force N·m	Power ON		0.45	1.8	12	36 [20]*3
	Power OFF		0	0	0	0
	Electromagnetic Brake		–	–	12	20
Resolution*2			9000 P/R (0.04°/step), 18000 P/R (0.02°/step), 90000 P/R (0.004°/step), 180000 P/R (0.002°/step)			
Voltage and Frequency			24 VDC±10%	Single-phase 100-115 VAC, single-phase 200-230 VAC, three-phase 200-230 VAC –15 to +10% 50/60 Hz		
Power-Supply Input	24 VDC		0.9	–	–	–
	Input Current A	Single-Phase 100-115 VAC	–	2.9	4.4	6.5
		Single-Phase 200-230 VAC	–	1.9	2.7	4.1
		Three-Phase 200-230 VAC	–	1	1.4	2.2
Control Power Supply			24 VDC±5% 0.5 A			
Electromagnetic Brake*4 Power-Supply Input			–	–	24 VDC±5%*5 0.25 A	24 VDC±5%*5 0.25 A
Repetitive positioning accuracy		sec	±15 (±0.004°)			
Lost Motion		arc minute (degrees)	2 (0.033°)			
Angular Transmission Accuracy		arc minute (degrees)	4 (0.067°)		3 (0.05°)	2 (0.033°)
Permissible Thrust Load		N	100	500	2000	4000
Permissible Moment Load		N·m	2	10	50	100
Runout of Output Table Surface		mm	0.030			0.015
Runout of Output Table Inner (Outer) Diameter		mm	0.030	0.015		0.030
Parallelism of Output Table		mm	0.050	0.030		0.050
Degree of Protection			Single Shaft, Electromagnetic Brake Type: IP40 (IP20 for motor connector) Double Shaft: IP20			
Mass of Actuator Unit		kg	0.5	1.17	2.65 [2.95]*3	9.5 [10.1]*3

● A number indicating the desired length of **1** (1 m), **2** (2 m) or **3** (3 m) for the cable included with the product is entered where the box ◇ is located within the product name.

\*1 The back shaft of the motor in the double shaft type is intended for installing a slit disk. Do not apply load torque, overhung load or thrust load to the back shaft of the motor.

\*2 You can set 1 of 4 resolutions using the resolution select switch or resolution select input.

The resolution factory setting is 18000 P/R (0.02°/step).

\*3 The brackets [ ] indicate the specifications for the electromagnetic brake type.

\*4 A separate power supply for the electromagnetic brakes is required for the electromagnetic brake type.

\*5 If the wiring distance between the motor and driver is extended to 20 m min. using an accessory cable (sold separately), the 24 VDC±4% specification applies.

**Note**

● Depending on the driving conditions, a considerable amount of heat may be generated by the motor. Be sure to keep the temperature of the motor case at approximately 100°C max.

● The repetitive positioning accuracy is measured at a constant temperature (normal temperature) under a constant load.



● Speed – Torque Characteristics

**DG60**

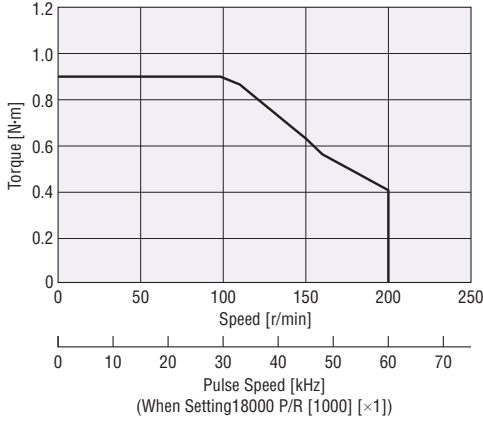

**DG85**

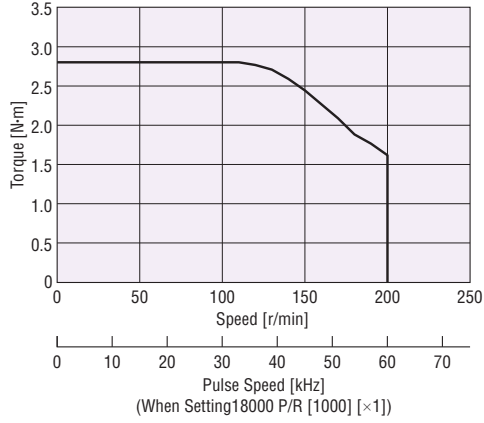

**DG130**

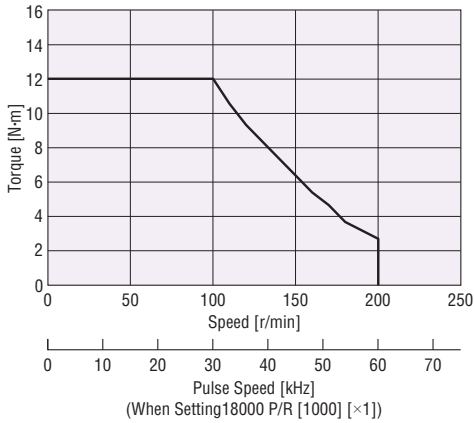

**DG200**

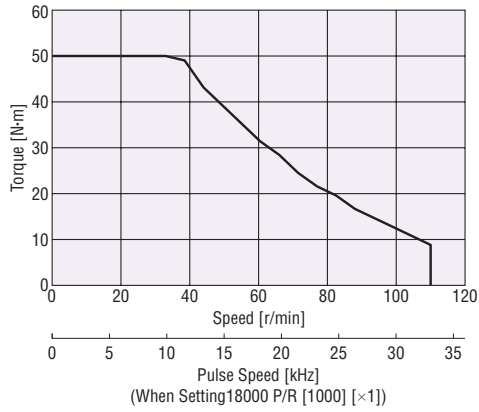

● Load Inertia - Positioning Time (Reference value)

**DG60**

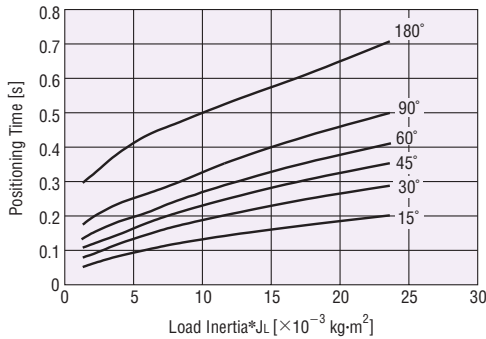

**DG85**

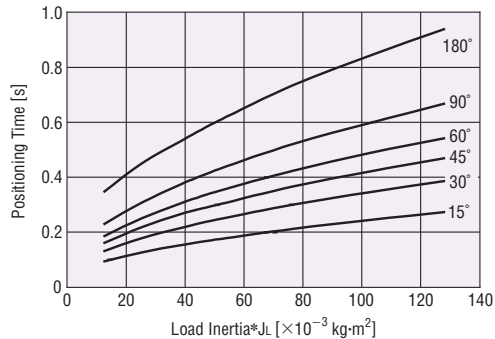

**DG130**

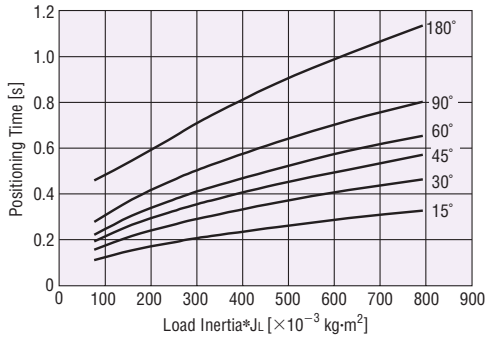

**DG200**

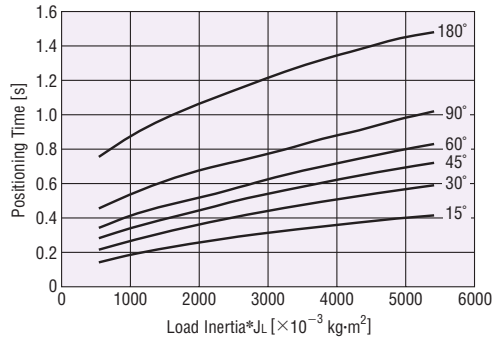

\*The load inertia refers to the inertia of the customer's work.

- Lineup
- Features
- How to Read Specifications Table
- System Configuration
- Product Line
- Specifications and Characteristics
- Dimensions
- Connection and Operation
- Combination List
- Accessories

● Mechanical Precision (At no load)

**DG60**

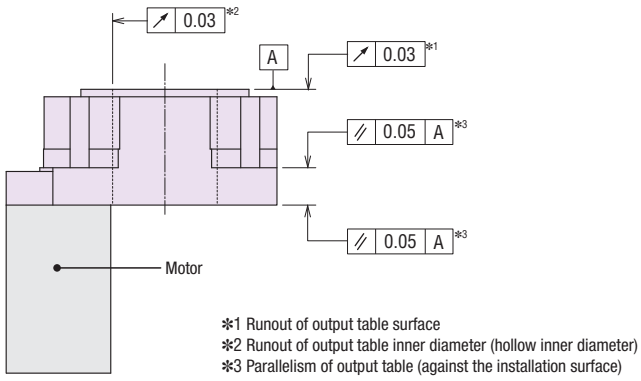

**DG85/DG130/DG200**

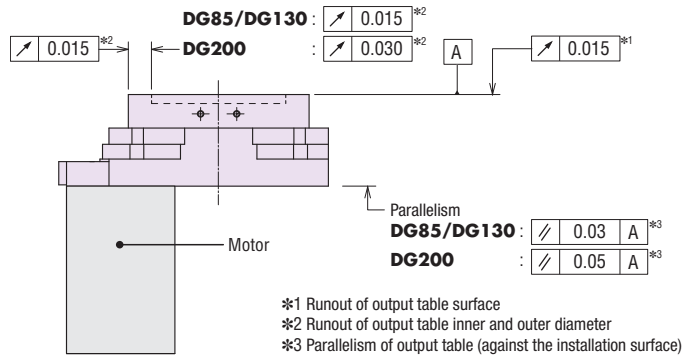

● Displacement by Moment Load (Reference value)

The output table will be displaced when it receives the moment load.

The graph plots the table displacement that occurs at distance L from the rotation center of the output table when a given moment load is applied in the negative direction.

The displacement becomes approximately twofold when the moment load is applied in both the positive and negative directions.

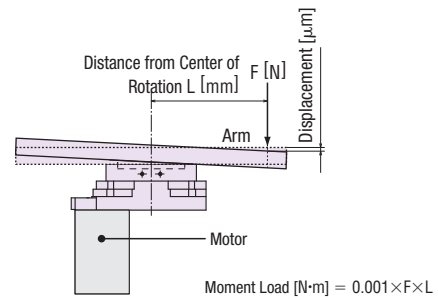

**DG60**

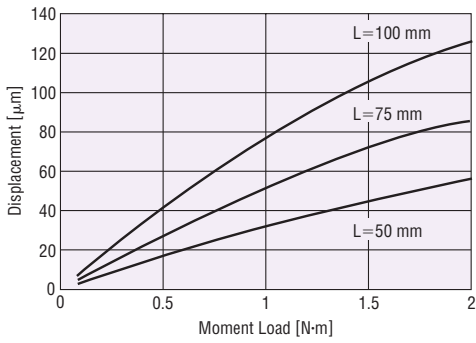

**DG85**

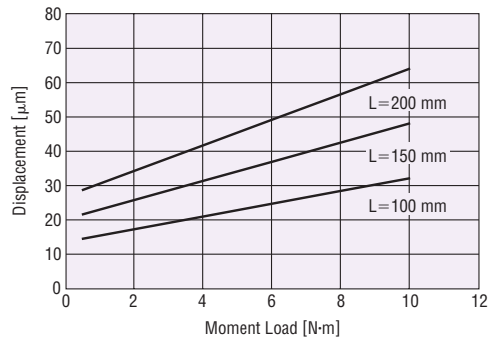

**DG130**

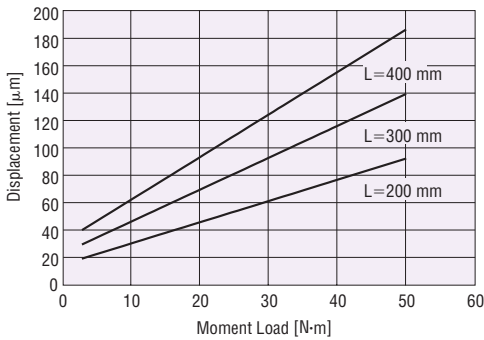

**DG200**

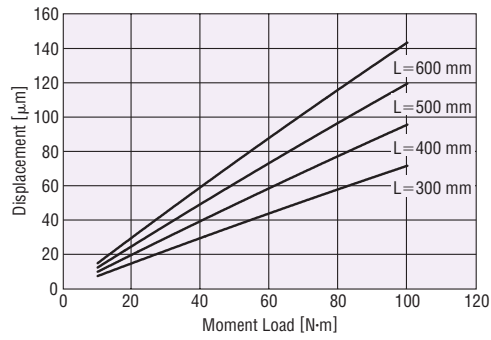

## Driver Specifications

	Built-In Controller Type	Pulse Input Type
Max. Input Pulse Frequency	—	Line driver output by programmable controller: 500 kHz (When the pulse duty is 50%) Open-collector output by programmable controller: 250 kHz (When the pulse duty is 50%)*
Number of Positioning Data Sets	64 Points	—
Positioning Operation	Independent	○
	Linked	○
	Linked 2	○
	Sequential	○
	Direct	○
Continuous Operation	○	—
JOG Operation	○	—
Return-To-Home Operation	○	—
Test Operation	○	○
Absolute Backup System	○	—
Control Module <b>OPX-2A</b>	○	○
Data Setting Software <b>MEXE02</b>	○	○

\* The values when the separately-sold general-purpose cable is used. General-purpose cable → Page 49

## Built-In Controller Type RS-485 Communication Specification

Protocol	Modbus protocol (Modbus RTU mode)
Electrical Characteristics	EIA-485 based Use twisted-pair wire (TIA/EIA-568B CAT5e or higher is recommended), and set a max. total length of 50 m.
Sending and Receiving Method	Half-duplex communication
Baud Rate	9600 bps/19200 bps/38400 bps/57600 bps/115200 bps
Physical Layer	Start-stop synchronization method (Data: 8 bits, stop bit: 1 bit/2 bits, parity: none/even numbers/odd numbers)
Connection Type	Up to 31 can be connected to each programmable controller (master equipment).

## General Specifications

### DC Power-Supply Input

	Motor	Driver	
		Built-In Controller Type	Pulse Input Type
Heat-Resistant Class	130 (B)	—	
Insulation Resistance	100 M $\Omega$ min. when measured with a 500 VDC megger between the following locations: <ul style="list-style-type: none"> <li>Case – Motor and Sensor Windings</li> <li>Case – Electromagnetic Brake Windings</li> </ul>	100 M $\Omega$ min. when measured with a 500 VDC megger between the following locations: <ul style="list-style-type: none"> <li>FG Terminal – Power Input Terminal</li> </ul>	—
Dielectric Voltage	No abnormality is judged with the following application for 1 minute: <ul style="list-style-type: none"> <li>Case – Motor and Sensor Windings 1.0 kV, 50 Hz or 60 Hz</li> <li>Case – Electromagnetic Brake Windings 1.0 kV, 50 Hz or 60 Hz</li> </ul>	No abnormality is judged with the following application for 1 minute: <ul style="list-style-type: none"> <li>FG Terminal – Power Input Terminal 500 VAC 50 Hz or 60 Hz</li> </ul>	—
Operating Environment (In operation)	Ambient Temperature	0 to +50°C (non-freezing) 0 to +40°C (non-freezing) when home sensor set (accessory) is attached	
	Ambient Humidity	85% max. (non-condensing)	
	Atmosphere	Use in an area without corrosive gases and dust. The product should not be exposed to water, oil or other liquids.	
Degree of Protection	Single Shaft: IP40 (IP20 for motor connector) Double Shaft: IP20	IP10	IP20

#### Note

● Do not perform the insulation resistance test or dielectric voltage withstand test while the actuator and driver are connected.

## General Specifications

### AC Power-Supply Input

		Motor	Driver	
			Built-In Controller Type	Pulse Input Type
Heat-Resistant Class		130 (B)	-	
Insulation Resistance		100 M $\Omega$ min. when measured with a 500 VDC megger between the following locations: <ul style="list-style-type: none"> <li>· Case – Motor and Sensor Windings</li> <li>· Case – Electromagnetic Brake Windings</li> </ul>	100 M $\Omega$ min. when measured with a 500 VDC megger between the following locations: <ul style="list-style-type: none"> <li>· PE Terminal – Power Supply Terminal</li> <li>· Signal I/O Terminal – Power Supply Terminal</li> </ul>	
Dielectric Voltage		No abnormality is judged with the following application for 1 minute: <ul style="list-style-type: none"> <li>· Case – Motor and Sensor Windings      1.5 kV, 50 Hz or 60 Hz</li> <li>· Case – Electromagnetic Brake Windings      1.5 kV, 50 Hz or 60 Hz</li> </ul>	No abnormality is judged with the following application for 1 minute: <ul style="list-style-type: none"> <li>· PE Terminal – Power Supply Terminal 1.8 kV, 50 Hz or 60 Hz</li> <li>· Signal I/O Terminal – Power Supply Terminal 1.9 kV, 50 Hz or 60 Hz</li> <li>· PE Terminal – Power Supply Terminal 1.5 kV, 50 Hz or 60 Hz</li> <li>· Signal I/O Terminal – Power Supply Terminal 1.8 kV, 50 Hz or 60 Hz</li> </ul>	
Operating Environment (In operation)	Ambient Temperature	0 to +50°C (non-freezing) 0 to +40°C (non-freezing) when home sensor set (accessory) is attached	0 to +55°C (non-freezing)*	0 to +50°C (non-freezing)*
	Ambient Humidity	85% max. (non-condensing)		
	Atmosphere	Use in an area without corrosive gases and dust. The product should not be exposed to water, oil or other liquids.		
Degree of Protection		Single Shaft, Electromagnetic Brake Type: IP40 (IP20 for motor connector) Double Shaft: IP20	IP10	IP20

\*When a heat sink is installed that is equivalent to an aluminum plate size of at least 200 × 200 mm and 2 mm thickness

**Note**

● Do not perform the insulation resistance test or dielectric voltage withstand test while the actuator and driver are connected.

# Dimensions (Unit = mm)

## Actuator

Product Name	Actuator Product Name	Mass
<b>DG60-ARAK</b> □2-◇	DGM60-ARAK	0.5 kg
<b>DG60-ARBK</b> □2-◇	DGM60-ARBK	

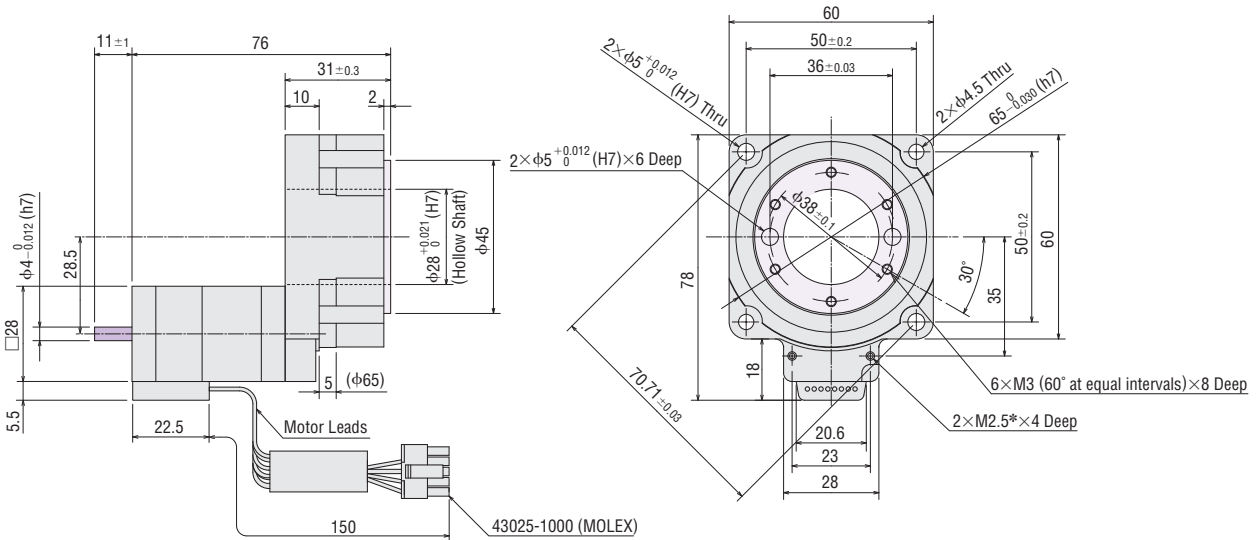

- These dimensions are for double shaft models. For single shaft models, ignore the shaft in the shaded areas.
- The shaded areas are rotating parts.

\*Use M2.5 screw holes when installing the home sensor set (sold separately). Do not use these holes for any purpose other than to install the home sensor.

Product Name	Actuator Product Name	Mass
<b>DG85R-ARAA</b> □2-◇	DGM85R-ARAC	1.17 kg
<b>DG85R-ARAC</b> □2-◇		
<b>DG85R-ARAS</b> □2-◇		
<b>DG85R-ARBA</b> □2-◇	DGM85R-ARBC	
<b>DG85R-ARBC</b> □2-◇		
<b>DG85R-ARBS2</b> -◇		

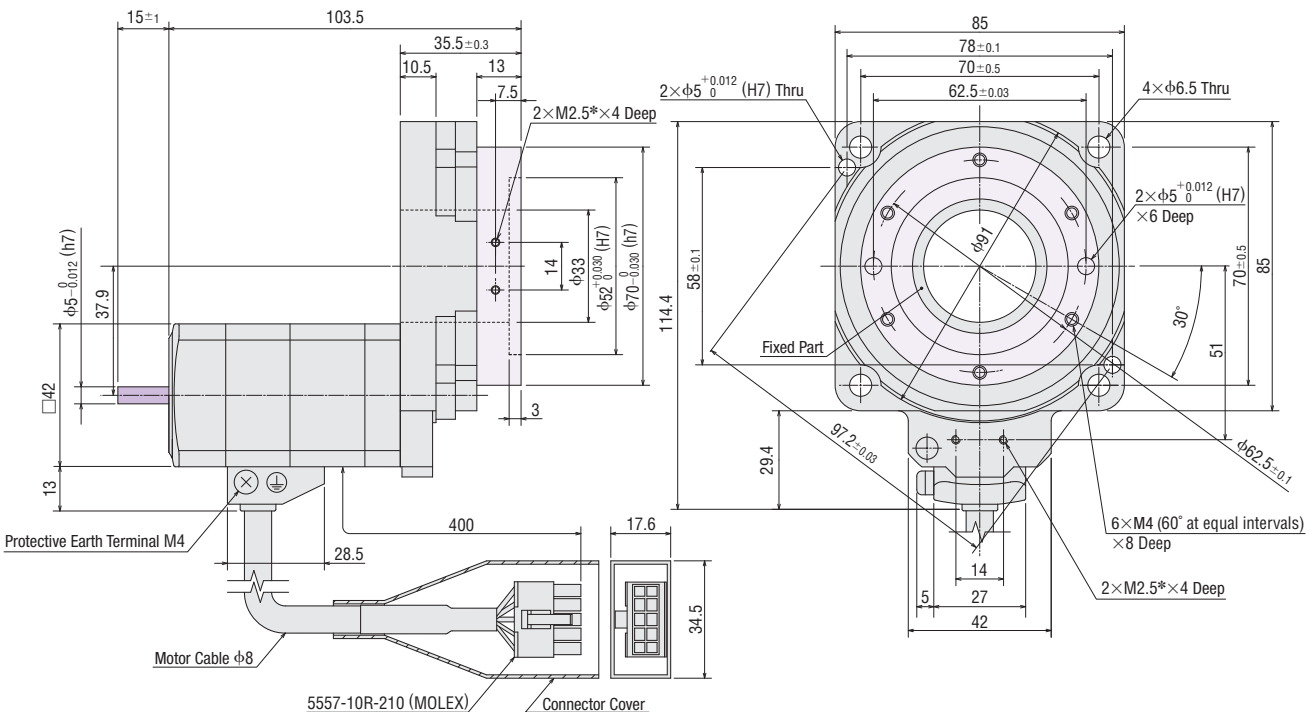

- These dimensions are for double shaft models. For single shaft models, ignore the shaft in the shaded areas.
- The shaded areas are rotating parts.

\*Use M2.5 screw holes when installing the home sensor set (sold separately). Do not use these holes for any purpose other than to install the home sensor.

● **D** indicating the driver type (built-in controller type) is entered where the box □ is located within the product name. A code for the pulse input type is not entered in the box □. A number indicating the desired length of **1** (1 m), **2** (2 m) or **3** (3 m) for the cable included with the product is entered where the box ◇ is located within the product name.

Lineup

Features

How to Read Specifications Table

System Configuration

Product Line

Specifications and Characteristics

Dimensions

Connection and Operation

Combination List

Accessories

Product Name	Actuator Product Name	Mass
<b>DG130R-ARAA</b> □2-◇	DGM130R-ARAC	2.65 kg
<b>DG130R-ARAC</b> □2-◇		
<b>DG130R-ARAS2</b> -◇		
<b>DG130R-ARBA</b> □2-◇	DGM130R-ARBC	
<b>DG130R-ARBC</b> □2-◇		
<b>DG130R-ARBS2</b> -◇		

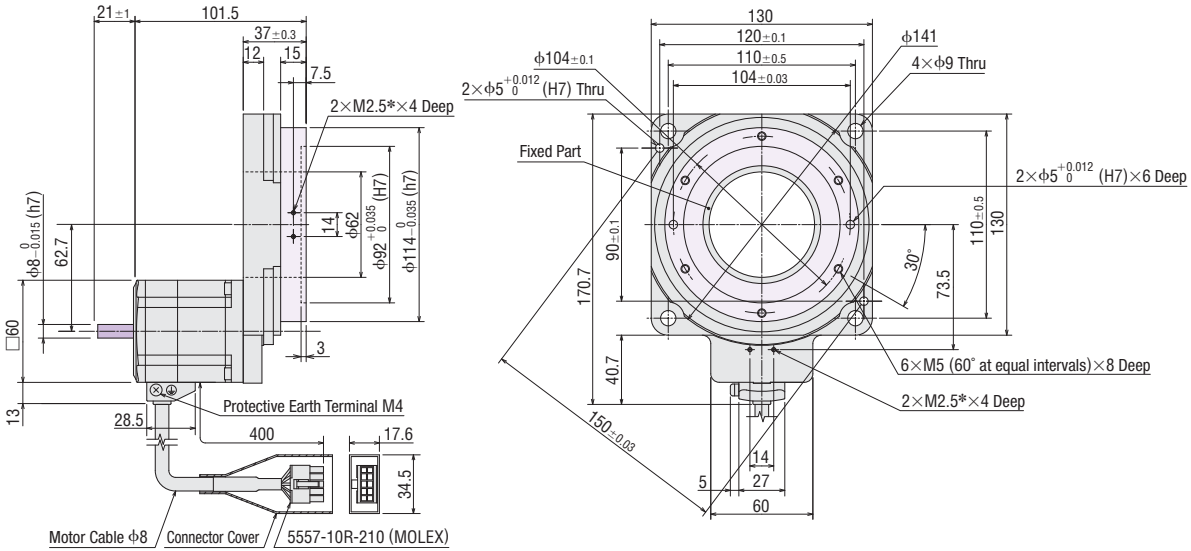

- These dimensions are for double shaft models.  
For single shaft models, ignore the shaft in the shaded areas.
- The shaded areas are rotating parts.

\*Use M2.5 screw holes when installing the home sensor set (sold separately).  
Do not use these holes for any purpose other than to install the home sensor.

Product Name	Actuator Product Name	Mass
<b>DG130R-ARMA</b> □2-◇	DGM130R-ARMC	2.95 kg
<b>DG130R-ARMC</b> □2-◇		
<b>DG130R-ARMS2</b> -◇		

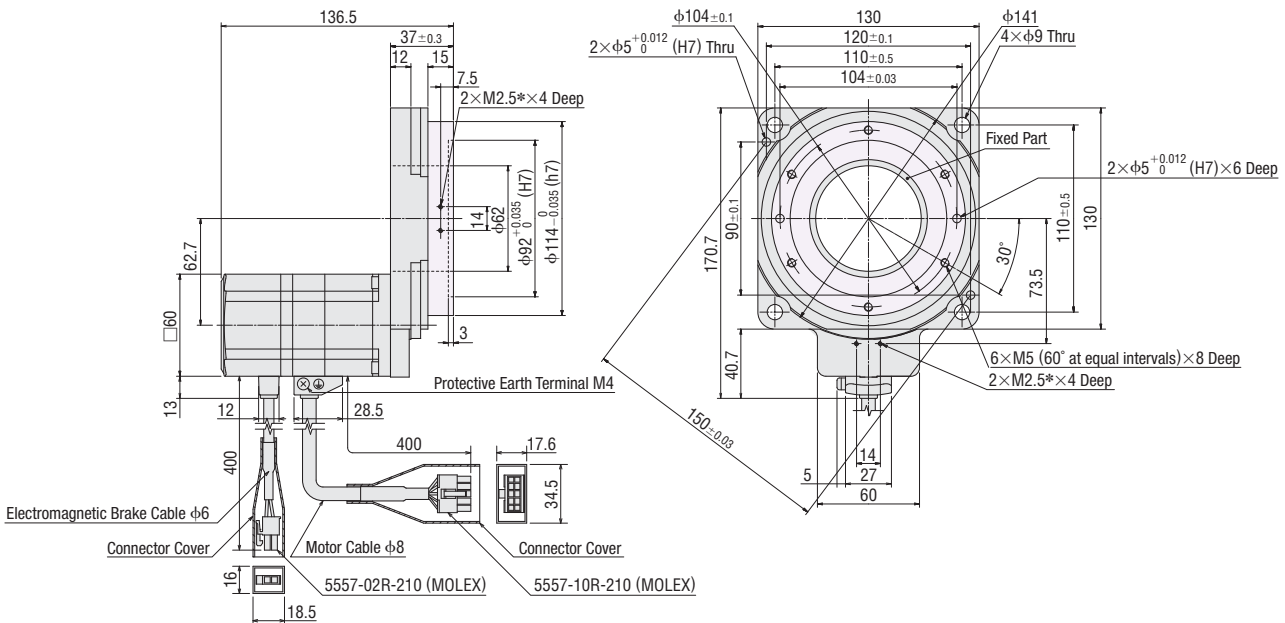

- The shaded areas are rotating parts.

\*Use M2.5 screw holes when installing the home sensor set (sold separately).  
Do not use these holes for any purpose other than to install the home sensor.

● **D** indicating the driver type (built-in controller type) is entered where the box □ is located within the product name. A code for the pulse input type is not entered in the box □.  
A number indicating the desired length of **1** (1 m), **2** (2 m) or **3** (3 m) for the cable included with the product is entered where the box ◇ is located within the product name.

Product Name	Actuator Product Name	Mass
<b>DG200R-ARAA</b> □2-◇	DGM200R-ARAC	9.5 kg
<b>DG200R-ARAC</b> □2-◇		
<b>DG200R-ARAS2</b> -◇		
<b>DG200R-ARBA</b> □2-◇	DGM200R-ARBC	
<b>DG200R-ARBC</b> □2-◇		
<b>DG200R-ARBS2</b> -◇		

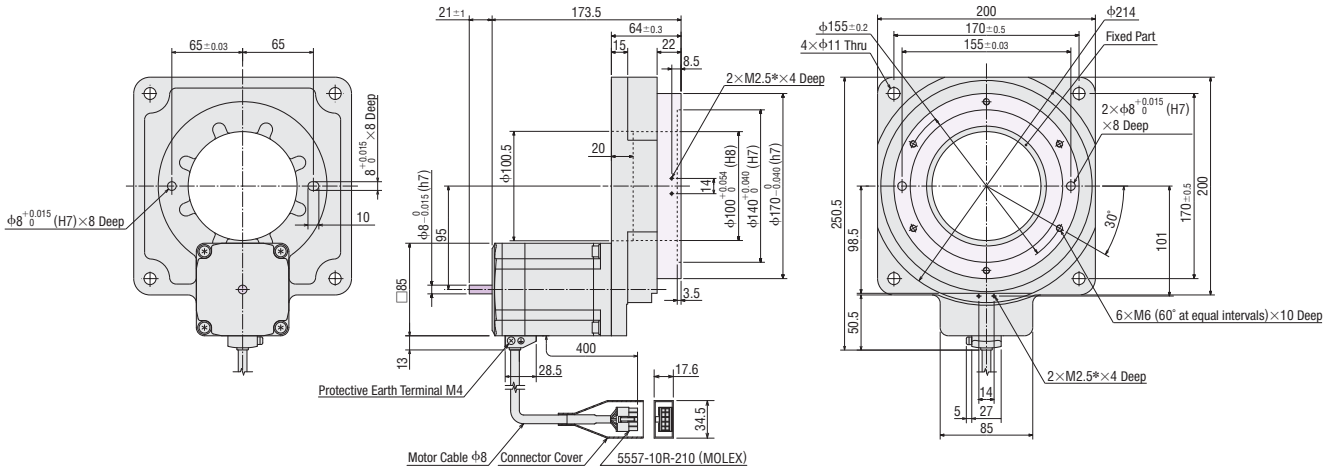

- These dimensions are for double shaft models.  
For single shaft models, ignore the shaft in the shaded  areas.
  - The shaded areas  are rotating parts.
- \*Use M2.5 screw holes when installing the home sensor set (sold separately).  
Do not use these holes for any purpose other than to install the home sensor.

Product Name	Actuator Product Name	Mass
<b>DG200R-ARMA</b> □2-◇	DGM200R-ARMC	10.1 kg
<b>DG200R-ARMC</b> □2-◇		
<b>DG200R-ARMS2</b> -◇		

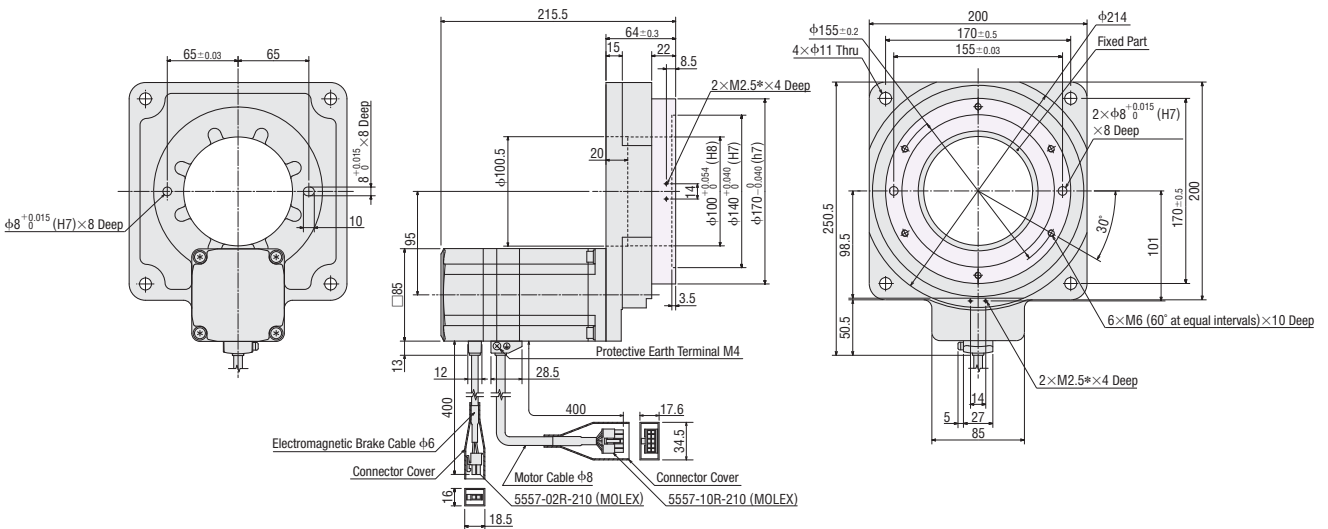

- The shaded areas  are rotating parts.
- \*Use M2.5 screw holes when installing the home sensor set (sold separately).  
Do not use these holes for any purpose other than to install the home sensor.

● **D** indicating the driver type (built-in controller type) is entered where the box □ is located within the product name. A code for the pulse input type is not entered in the box □.  
A number indicating the desired length of **1** (1 m), **2** (2 m) or **3** (3 m) for the cable included with the product is entered where the box ◇ is located within the product name.

Lineup

Features

How to Read  
Specifications TableSystem  
Configuration

Product Line

Specifications and  
Characteristics

Dimensions

Connection  
and OperationCombination  
List

Accessories

● Cables for Motor (Included), Cables for Electromagnetic Brake (Included)

◇ DC Power Supply Input, Common to All Types

● Cables for Motor

Cable Type	Length L (m)
Cable for Motor 1 m	1
Cable for Motor 2 m	2
Cable for Motor 3 m	3

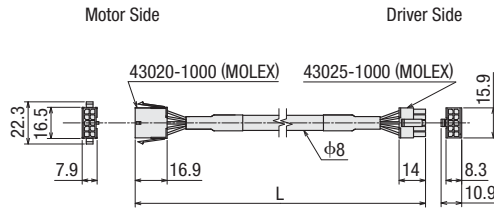

◇ AC Power Supply Input, Common to All Types

● Cable for Motor

Cable Type	Length L (m)
Cable for Motor 1 m	1
Cable for Motor 2 m	2
Cable for Motor 3 m	3

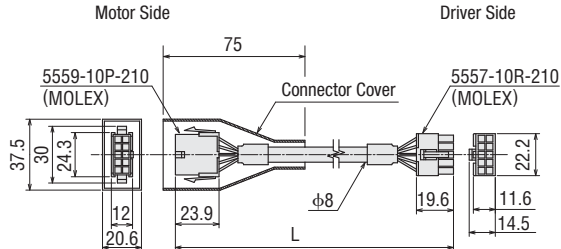

● Cable for Electromagnetic Brake (Electromagnetic brake type only)

Cable Type	Length L (m)
Cable for Electromagnetic Brake 1 m	1
Cable for Electromagnetic Brake 2 m	2
Cable for Electromagnetic Brake 3 m	3

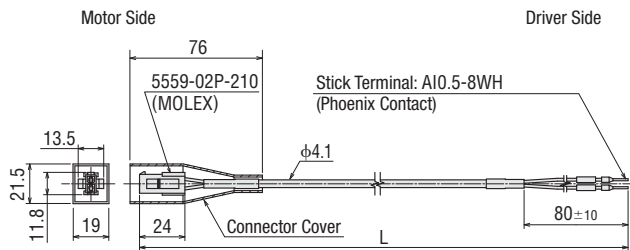

● Driver

◇ Built-In Controller Type

● DC Power Supply Input (ARD-KD)

Mass: 0.17 kg

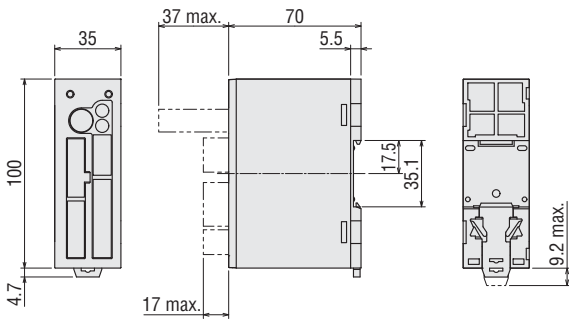

● Included

- Power Input Terminal Connector (CN1)  
Connector: MC1,5/5-STF-3,5 (Phoenix Contact)
- Sensor Signal Connector (CN5)  
Connector: FK-MC0,5/5-ST-2,5 (Phoenix Contact)
- Input Signal Connector (CN8)  
Connector: FK-MC0,5/9-ST-2,5 (Phoenix Contact)
- Output Signal Connector (CN9)  
Connector: FK-MC0,5/7-ST-2,5 (Phoenix Contact)

● AC Power Supply Input (ARD-AD, ARD-CD)

Mass: 0.75 kg

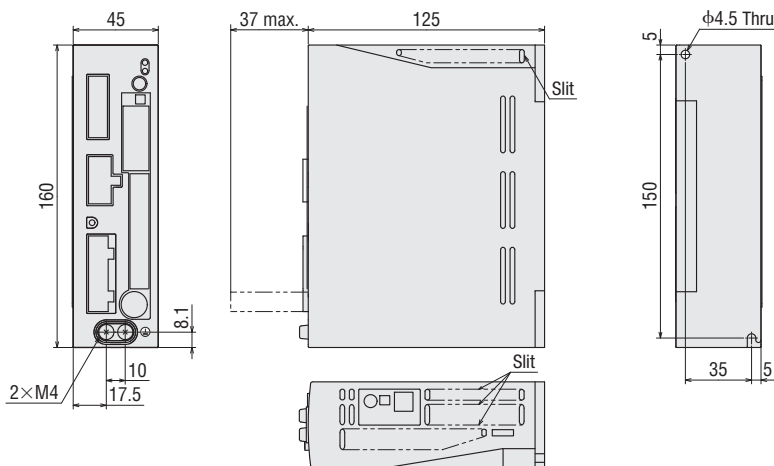

● Included

- Power Input Terminal Connector (CN1)  
Connector: MC1,5/6-STF-3,5 (Phoenix Contact)
- Sensor Signal Connector (CN5)  
Connector: FK-MC0,5/5-ST-2,5 (Phoenix Contact)
- Input Signal Connector (CN8)  
Connector: FK-MC0,5/9-ST-2,5 (Phoenix Contact)
- Output Signal Connector (CN9)  
Connector: FK-MC0,5/7-ST-2,5 (Phoenix Contact)
- Connector for Regeneration Unit Input/Main Power Input Terminals (CN3)  
Connector: 54928-0570 (MOLEX)



◇ Pulse Input Type

● DC Power Supply Input (ARD-K)

Mass: 0.17 kg

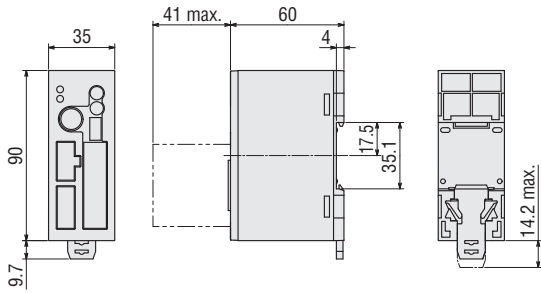

- Included
- Control I/O Connector (CN5)
- Case: 10336-52A0-008 (Sumitomo 3M)
- Connector: 10136-3000PE (Sumitomo 3M)
- Connector for Main Power Input/Frame Ground Terminals (CN1)
- Connector: MC1,5/3-STF-3,5 (Phoenix Contact)

● AC Power Supply Input (ARD-A, ARD-C, ARD-S)

Mass: 0.75 kg

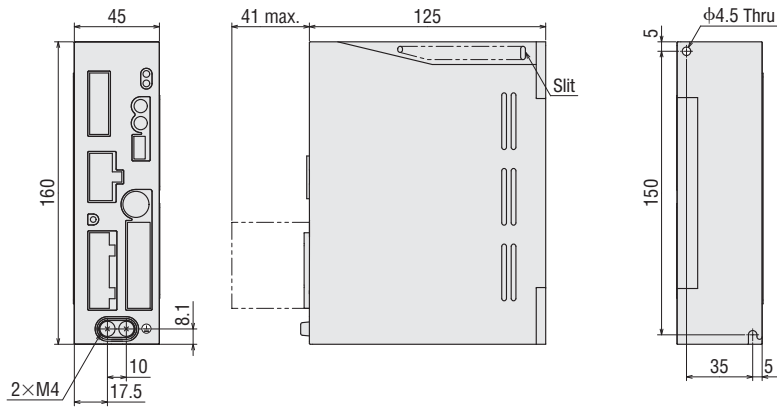

- Included
- Control I/O Connector (CN5)
- Case: 10336-52A0-008 (Sumitomo 3M)
- Connector: 10136-3000PE (Sumitomo 3M)
- Connector for Regeneration Unit Input/Main Power Input Terminals (CN3)
- Connector: 54928-0570 (MOLEX)
- Connector for 24 VDC Power-Supply Input/Regeneration Unit Thermal Input/Electromagnetic Brake Output Terminals (CN1)
- Connector: MC1,5/6-STF-3,5 (Phoenix Contact)

Lineup
Features
How to Read Specifications Table
System Configuration
Product Line
Specifications and Characteristics
Dimensions
Connection and Operation
Combination List
Accessories

## ■ Connection and Operation (Built-in controller type DC power supply input)

### ● Names and Functions of Driver Parts

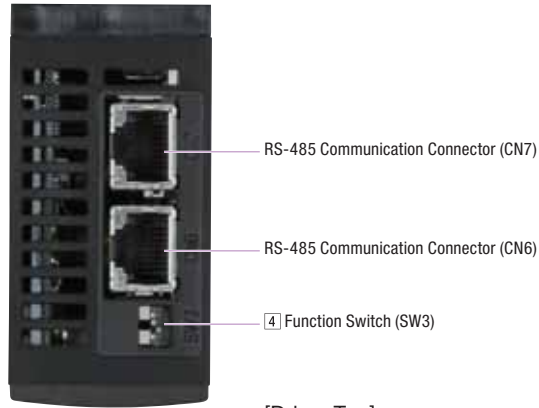

[Driver Top]

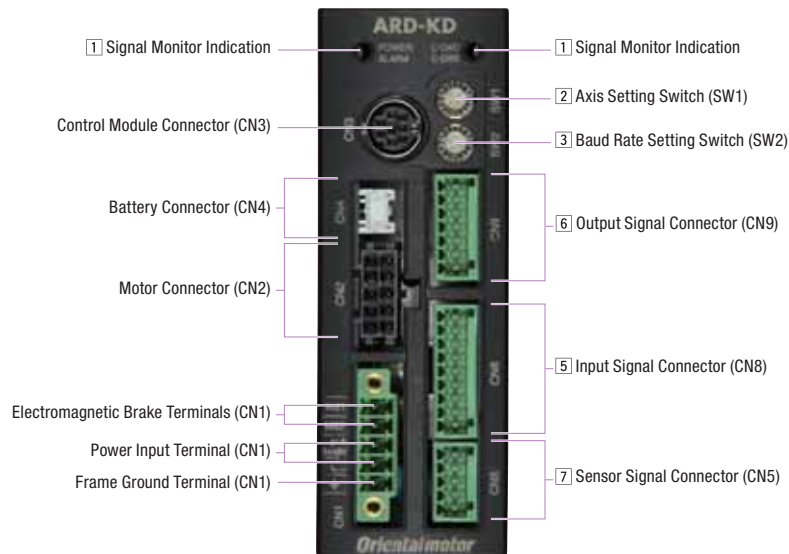

#### 1 Signal Monitor Indication

##### ◇ LED Indicator

Indication	Color	Function	Lighting Condition
POWER	Green	Power Supply Indication	When the power supply is input
ALARM	Red	Alarm Indication	When a protective function is activated (blinking)
C-DAT	Green	Communication Indication	When data is being received or sent
C-ERR	Red	Communication Error Indication	When a communication error has occurred

#### 2 Axis Setting Switch (SW1)

Indication	Function
SW1	Set when using with RS-485 communication. Set the axis number (Factory setting: 0).

#### 3 Baud Rate Setting Switch (SW2)

Indication	Function
SW2	Set when using with RS-485 communication. Set the baud rate (Factory setting: 7).

##### ◇ Settings for RS-485 Communication Speed

No.	Baud Rate (bps)
0	9600
1	19200
2	38400
3	57600
4	115200
5 to 6	Not used
7	625000 (Connect with a network converter)
8 to F	Not used

#### 4 Function Switch (SW3)

Indication	No.	Function
SW3	1	Use in combination with the axis setting switch (SW1) to set the axis number (Factory setting: OFF).
	2	Set the RS-485 communication protocol (Factory setting: OFF).
	3	Not used.
	4	Set the terminating resistor (120 Ω) for RS-485 communication (Factory setting: OFF). OFF: Terminating resistor not used ON: Terminating resistor used

#### ◇ Settings for RS-485 Communication Protocol

No.	Connection Destination	Connect with a Network Converter	Modbus RTU Mode
	2	OFF	ON

#### 5 Input Signal Connector (CN8)

Indication	Pin No.	Signal Name	Initial Value
CN8	1	IN0	HOME Execute the return-to-home operation.
	2	IN1	START Execute the positioning operation.
	3	IN2	M0
	4	IN3	M1 Use 3 bits to select the operating data number.
	5	IN4	M2
	6	IN5	FREE Stop actuator excitation and release the electromagnetic brake.
	7	IN6	STOP Stop the actuator.
	8	IN7	ALM-RST Reset current alarm.

● Sets the function to be assigned according to the parameter setting. The initial values are shown above. For details, refer to the User's Manual.

The following input signals can be assigned to input terminals IN0 to 7.

Input Signal				
0: Not used	8: MS0	18: STOP	36: R4	45: R13
1: FWD	9: MS1	24: ALM-RST	37: R5	46: R14
2: RVS	10: MS2	25: P-PRESET	38: R6	47: R15
3: HOME	11: MS3	26: P-CLR	39: R7	48: M0
4: START	12: MS4	27: HMI	40: R8	49: M1
5: SSTART	13: MS5	32: R0	41: R9	50: M2
6: +JOG	16: FREE	33: R1	42: R10	51: M3
7: -JOG	17: C-ON	34: R2	43: R11	52: M4
		35: R3	44: R12	53: M5

#### 6 Output Signal Connector (CN9)

Indication	Pin No.	Signal Name	Initial Value
CN9	1	OUT0	HOME-P Output when the actuator is in the home position.
	2	OUT1	END Output when the positioning operation is completed.
	3	OUT2	AREA1 Output when the actuator is within the range of area 1.
	4	OUT3	READY Output when the driver is ready for operation.
	5	OUT4	WNG Outputs the warning status for the driver.
	6	OUT5	ALM Outputs the alarm status for the driver (Normally close contact).

● Sets the function to be assigned according to the parameter setting. The initial values are shown above. For details, refer to the User's Manual.

The following output signals can be assigned to output terminals OUT0 to 5.

Output Signal					
0: Not used	9: MS1_R	33: R1	42: R10	51: M3_R	67: READY
1: FWD_R	10: MS2_R	34: R2	43: R11	52: M4_R	68: MOVE
2: RVS_R	11: MS3_R	35: R3	44: R12	53: M5_R	69: END
3: HOME_R	12: MS4_R	36: R4	45: R13	60: +LS_R	70: HOME-P
4: START_R	13: MS5_R	37: R5	46: R14	61: -LS_R	71: TLC
5: SSTART_R	16: FREE_R	38: R6	47: R15	62: HOMES_R	72: TIM
6: +JOG_R	17: C-ON_R	39: R7	48: M0_R	63: SLIT_R	73: AREA1
7: -JOG_R	18: STOP_R	40: R8	49: M1_R	65: ALM	74: AREA2
8: MS0_R	32: R0	41: R9	50: M2_R	66: WNG	75: AREA3
					80: S-BSY

#### 7 Sensor Signal Input (CN5)

Indication	Pin No.	Signal Name	Initial Value
CN5	1	+LS	+Side Limit Sensor Input
	2	-LS	-Side Limit Sensor Input
	3	HOMES	Mechanical Home Sensor Input
	4	SLIT	Slit Sensor Input
	5	IN-COM2	Common for Sensors

## ■ Connection and Operation (Built-in controller type AC power supply input)

### ● Names and Functions of Driver Parts

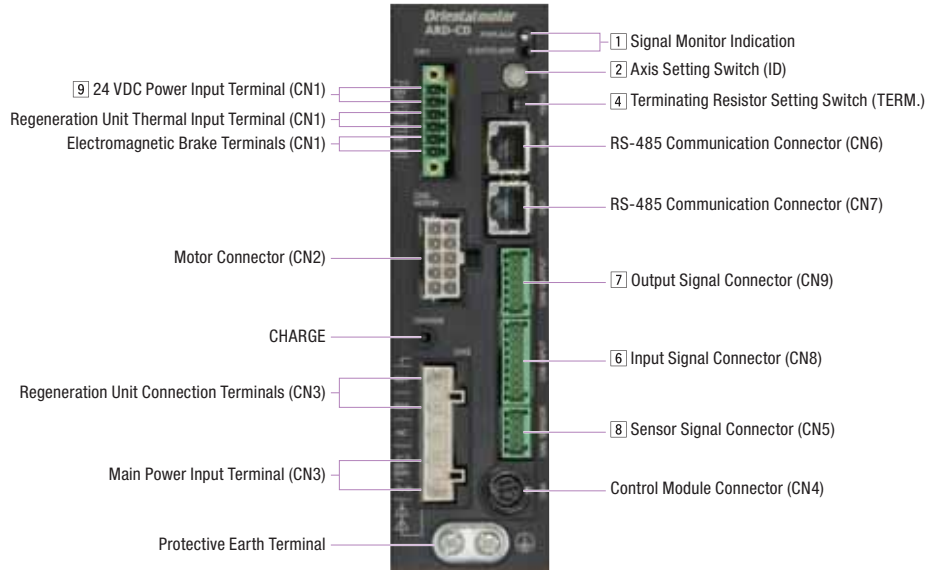

[Driver Bottom]

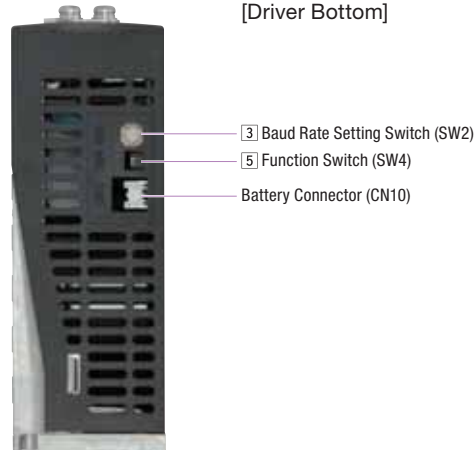

#### 1 Signal Monitor Indication

##### ◇ LED Indicator

Indication	Color	Function	Lighting Condition
PWR	Green	Power Supply Indication	When 24 VDC power supply is input
ALM	Red	Alarm Indication	When a protective function is activated (blinking)
C-DAT	Green	Communication Indication	When data is being received or sent
C-ERR	Red	Communication Error Indication	When a communication error has occurred

#### 2 Axis Setting Switch (ID)

Indication	Switch Name	Function
ID	Axis Setting Switch	Set when using with RS-485 communication. Set the axis number (Factory setting: 0).

#### 3 Baud Rate Setting Switch (SW2)

Indication	Switch Name	Function
SW2	Baud Rate Setting Switch	Set when using with RS-485 communication. Set the baud rate (Factory setting: 7).

##### ◇ Settings for RS-485 Communication Speed

No.	Baud Rate (bps)
0	9600
1	19200
2	38400
3	57600
4	115200
5 to 6	Not used
7	625000 (Connect with a network converter)
8 to F	Not used

**4 Terminating Resistor Setting Switch (TERM.)**

Indication	No.	Function
TERM.	1	Set the terminating resistor (120 Ω) for RS-485 communication (Factory setting: OFF).
	2	OFF: Terminating resistor not used ON: Terminating resistor used

\* Configure both No. 1 and No. 2 to the same setting.

**5 Function Switch (SW4)**

Indication	No.	Function
SW4	1	Use in combination with the axis setting switch (ID) to set the axis number (Factory setting: OFF).
	2	Set the RS-485 communication protocol (Factory setting: OFF).

**◇ Settings for RS-485 Communication Protocol**

No.	Connection Destination	Connect with a Network Converter	Modbus RTU Mode
	2	OFF	ON

**6 Input Signal Connector (CN8)**

Indication	Pin No.	Signal Name	Initial Value
CN8	1	IN0	HOME Execute the return-to-home operation.
	2	IN1	START Execute the positioning operation.
	3	IN2	M0
	4	IN3	M1
	5	IN4	M2
	6	IN5	FREE Stop actuator excitation and release the electromagnetic brake.
	7	IN6	STOP Stop the actuator.
	8	IN7	ALM-RST Reset current alarm.

\*Sets the function to be assigned according to the parameter setting. The initial values are shown above. For details, refer to the User's Manual.

The following input signals can be assigned to input terminals IN0 to 7.

Input Signal								
0: Not used	5: SSTART	10: MS2	17: C-ON	27: HMI	36: R4	41: R9	46: R14	51: M3
1: FWD	6: +JOG	11: MS3	18: STOP	32: R0	37: R5	42: R10	47: R15	52: M4
2: RVS	7: -JOG	12: MS4	24: ALM-RST	33: R1	38: R6	43: R11	48: M0	53: M5
3: HOME	8: MS0	13: MS5	25: P-PRESET	34: R2	39: R7	44: R12	49: M1	
4: START	9: MS1	16: FREE	26: P-CLR	35: R3	40: R8	45: R13	50: M2	

**7 Output Signal Connector (CN9)**

Indication	Pin No.	Signal Name	Initial Value
CN9	1	OUT0	HOME-P Output when the actuator is in the home position.
	2	OUT1	END Output when the positioning operation is completed.
	3	OUT2	AREA1 Output when the actuator is within the range of area 1.
	4	OUT3	READY Output when the driver is ready for operation.
	5	OUT4	WNG Outputs the warning status for the driver.
	6	OUT5	ALM Outputs the alarm status for the driver (Normally close contact).

\*Sets the function to be assigned according to the parameter setting. The initial values are shown above. For details, refer to the User's Manual.

The following output signals can be assigned to output terminals OUT0 to 5.

Output Signal								
0: Not used	7: -JOG_R	16: FREE_R	36: R4	43: R11	50: M2_R	63: SLIT_R	71: TLC	
1: FWD_R	8: MS0_R	17: C-ON_R	37: R5	44: R12	51: M3_R	65: ALM	72: TIM	
2: RVS_R	9: MS1_R	18: STOP_R	38: R6	45: R13	52: M4_R	66: WNG	73: AREA1	
3: HOME_R	10: MS2_R	32: R0	39: R7	46: R14	53: M5_R	67: READY	74: AREA2	
4: START_R	11: MS3_R	33: R1	40: R8	47: R15	60: +LS_R	68: MOVE	75: AREA3	
5: SSTART_R	12: MS4_R	34: R2	41: R9	48: M0_R	61: -LS_R	69: END	80: S-BSY	
6: +JOG_R	13: MS5_R	35: R3	42: R10	49: M1_R	62: HOMES_R	70: HOME-P	82: MPS	

**8 Sensor Signal Connector (CN5)**

Indication	Pin No.	Signal Name	Initial Value
CN5	1	+LS	+Side Limit Sensor Input
	2	-LS	-Side Limit Sensor Input
	3	HOMES	Mechanical Home Sensor Input
	4	SLIT	Slit Sensor Input
	5	IN-COM2	Common for Sensors

**9 24 VDC Input/Regeneration Unit Thermal Input/Electromagnetic Brake Terminals (CN1)**

Indication	I/O	Terminal Name	Content
24V+	Input	24 VDC Power Input Terminal+	The power supply for the driver control circuit. Always connect when using.
24V-		24 VDC Power Input Terminal-	
TH1		Regeneration Unit Thermal Input Terminal	Connect the accessory (sold separately) regeneration unit ( <b>RGB100</b> ). When not connecting a regeneration unit, short these 2 terminals to each other.
TH2		Regeneration Unit Thermal Input Terminal	
MB1	Output power	Electromagnetic Brake Terminal -	For an electromagnetic brake actuator, connect the electromagnetic brake line here.
MB2		Electromagnetic Brake Terminal +	

● Connection Diagram (For AC power supply input)

◇ Connections with Peripheral Equipment

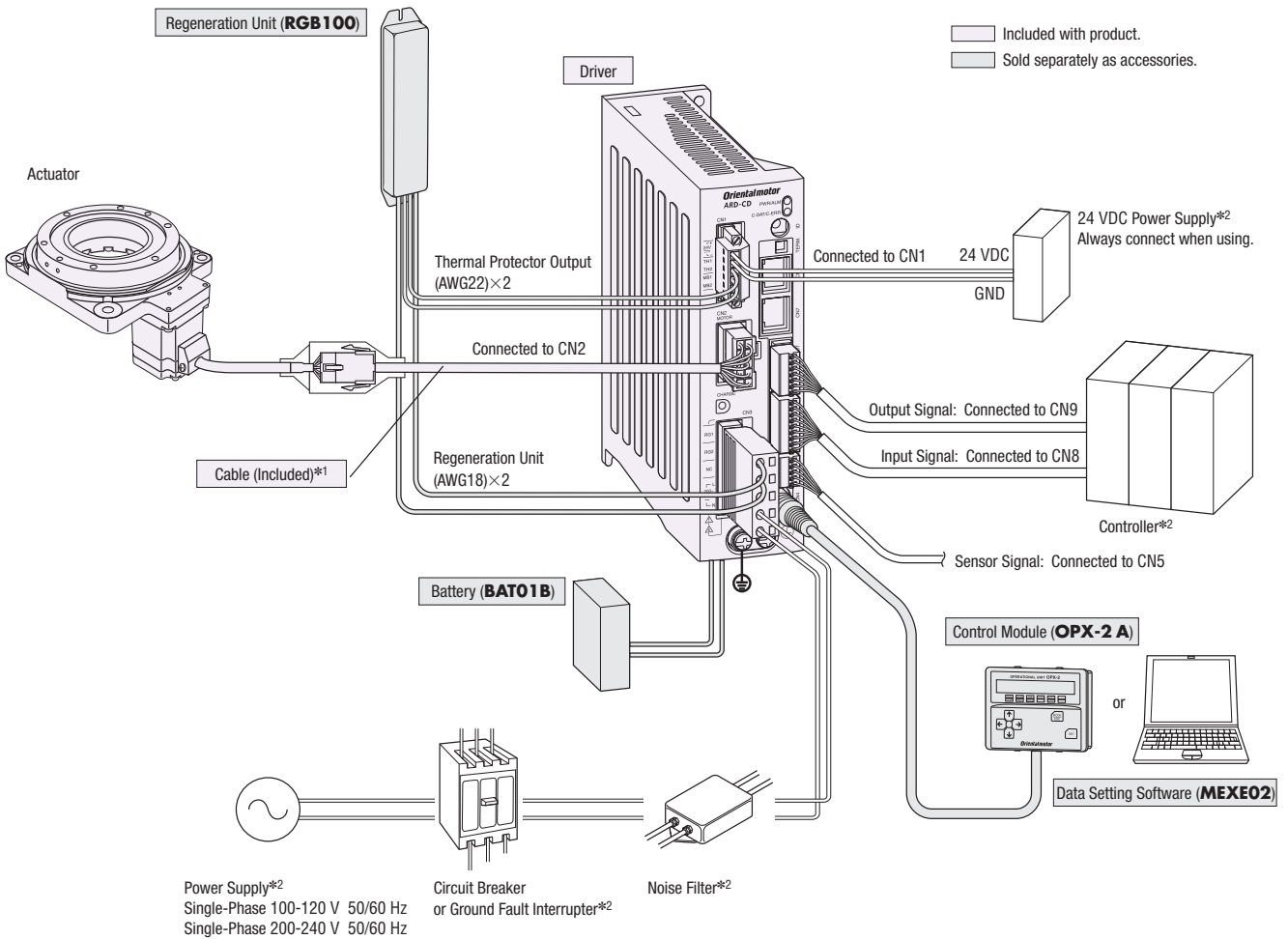

\*1 1 m, 2 m or 3 m cables are included. If you need cables longer than 3 m or flexible cables, select appropriate cables from the accessories (sold separately).  
 Keep the wiring distance between the actuator and driver to 30 m max.  
 \*2 Not supplied.

◇ Connecting the Main Power Supply

Prepare the following cable for the power supply lines.  
 Single-Phase 100-120 VAC: Three-Core Cable [AWG16 to 14 (1.25 to 2.0 mm<sup>2</sup>)]  
 Single-Phase 200-240 VAC: Three-Core Cable [AWG16 to 14 (1.25 to 2.0 mm<sup>2</sup>)]

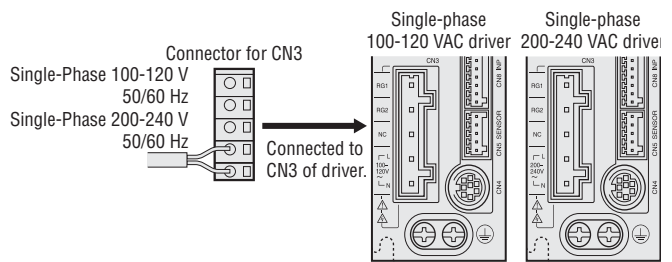

◇ Connecting the Control Power Supply

Prepare a 24 VDC power supply.

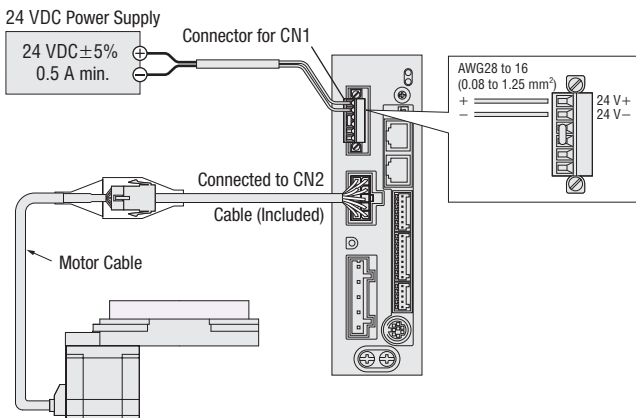

◇ Connecting the Electromagnetic Brake

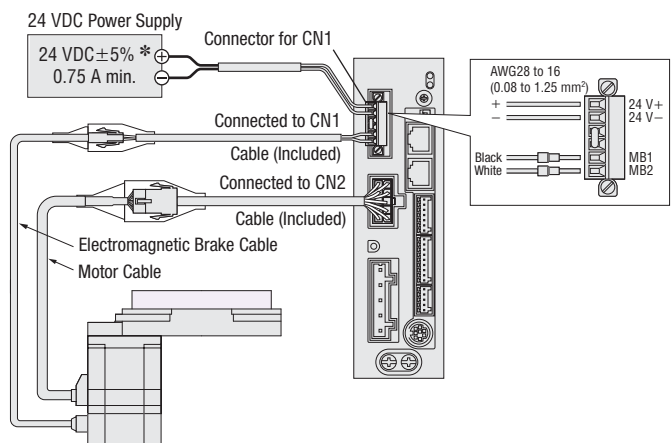

\*If the wiring distance is extended to 20 m min. using an accessory cable (sold separately), the 24 VDC ± 4% specification applies.

◇ Connection with Programmable Controller (Common to DC power supply input and AC power supply input)

● Connection Diagram for Connection with Current Sink Output Circuit

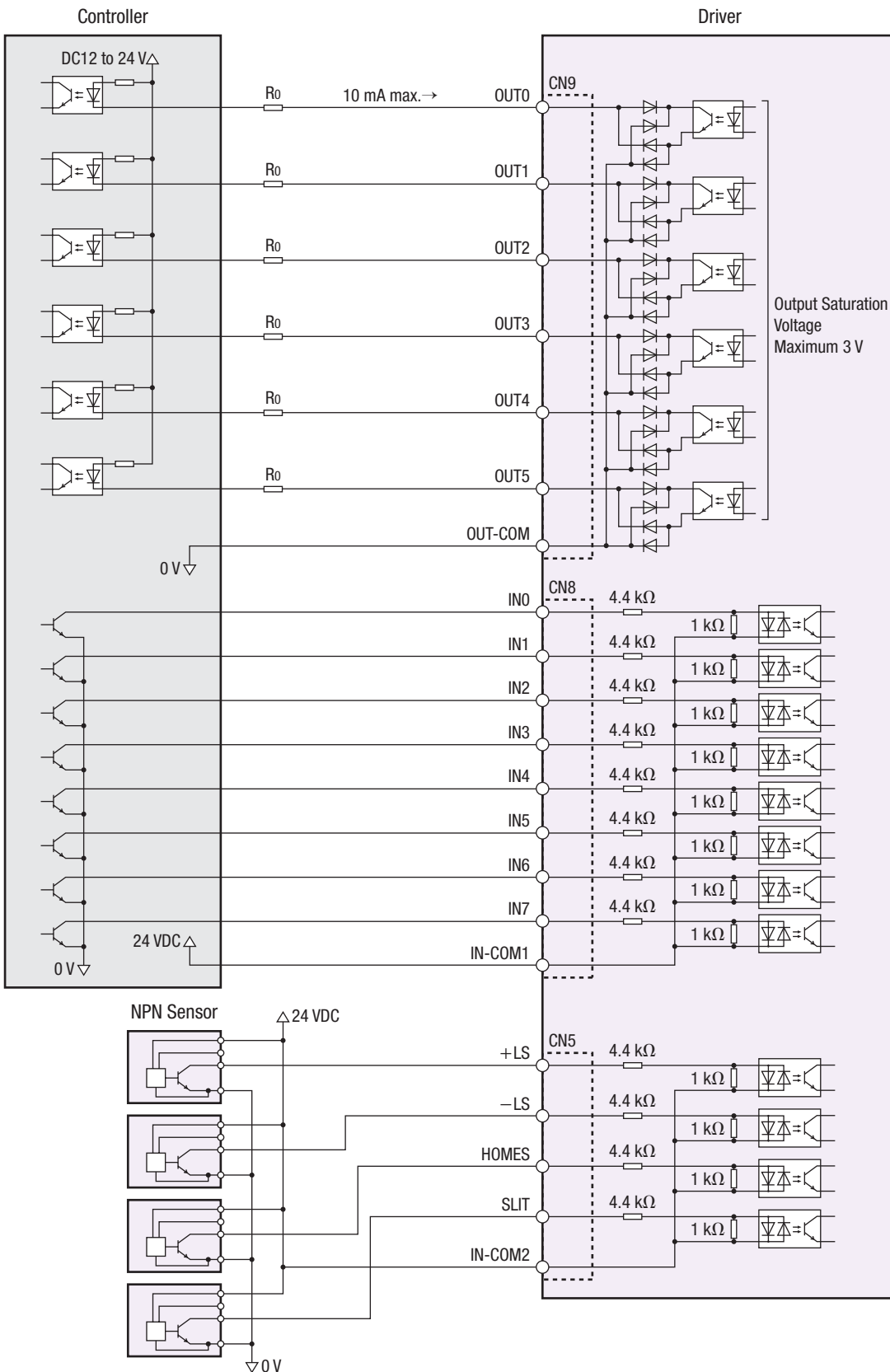

**Note**

- Use 24 VDC for the input signals.
- Use 24 VDC, 10 mA max. for the output signals. When the current value exceeds 10 mA, connect the external resistor  $R_o$  to reduce the current to 10 mA max.
- The saturation voltage for the output signals is 3 V max.
- Provide a distance of 200 mm min. between the signal lines and power lines (power supply lines, motor lines).  
Do not run the signal lines in the same piping as power lines or bundle them with power lines.
- If noise generated by the motor cable or power supply cable causes a problem with the specific wiring or layout, shield the cable or use ferrite cores.

Lineup

Features

How to Read Specifications Table

System Configuration

Product Line

Specifications and Characteristics

Dimensions

Connection and Operation

Combination List

Accessories

◇ Connection with Programmable Controller (Common to DC power supply input and AC power supply input)

● Connection Diagram for Connection with Current Source Output Circuit

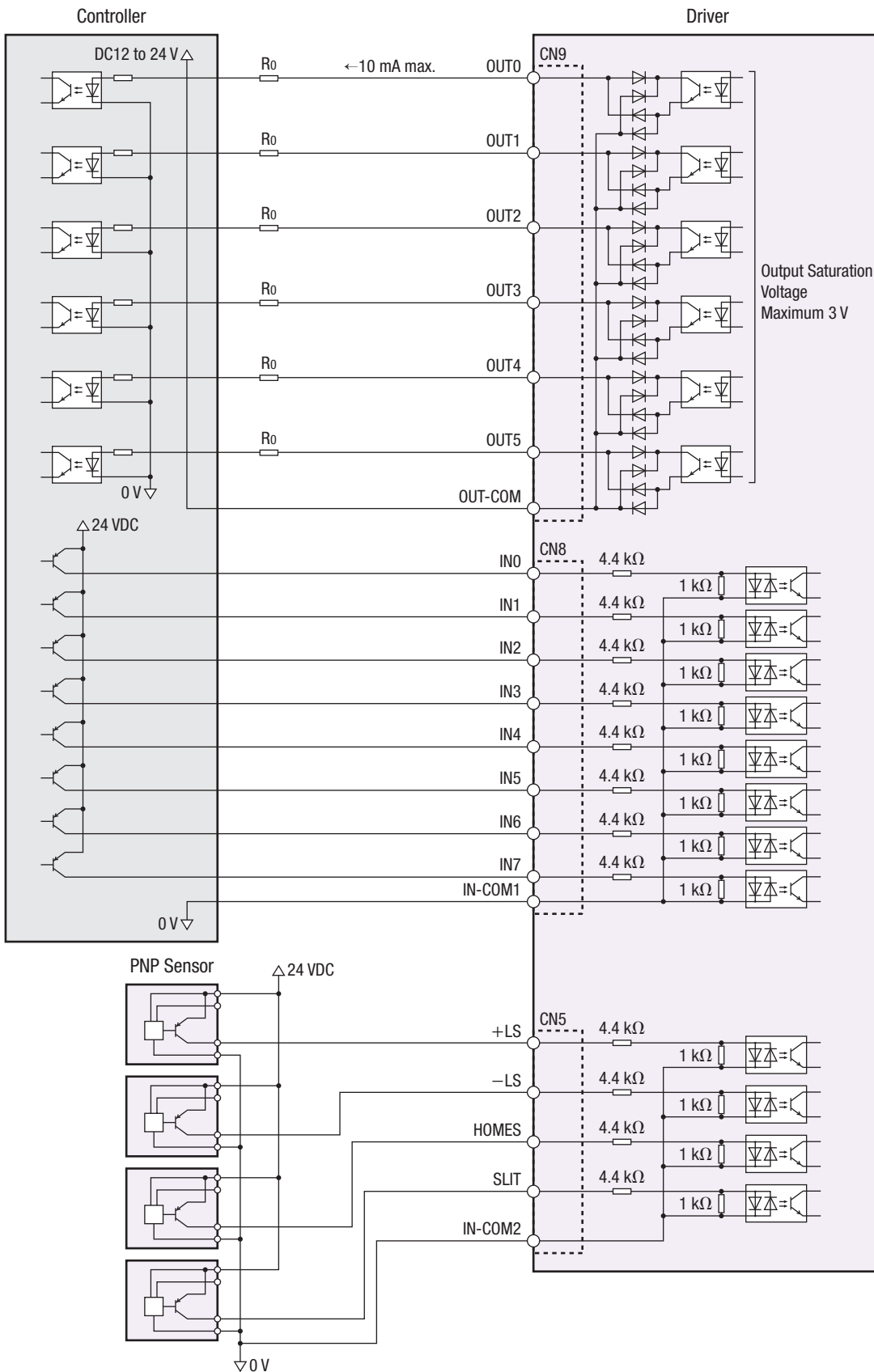

**Note**

- Use 24 VDC for the input signals.
- Use 24 VDC, 10 mA max. for the output signals. When the current value exceeds 10 mA, connect the external resistor  $R_0$  to reduce the current to 10 mA max.
- The saturation voltage for the output signals is 3 V max.
- Provide a distance of 200 mm min. between the signal lines and power lines (power supply lines, motor lines).  
Do not run the signal lines in the same piping as power lines or bundle them with power lines.
- If noise generated by the motor cable or power supply cable causes a problem with the specific wiring or layout, shield the cable or use ferrite cores.



# Connection and Operation (Pulse input type DC power supply input)

## Names and Functions of Driver Parts

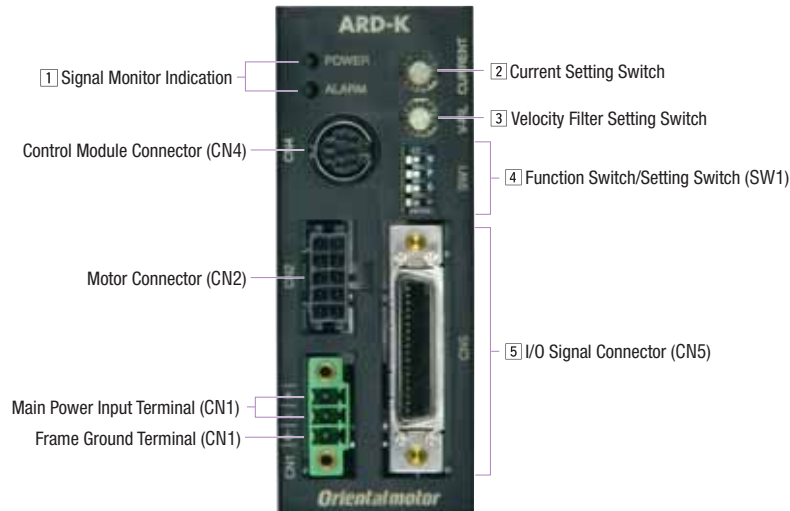

### 1 Signal Monitor Indication

#### ◇ LED Indicator

Indication	Color	Function	Lighting Condition
POWER	Green	Power Supply Indication	When the main power supply is input
ALARM	Red	Alarm Indication	When a protective function is activated (blinking)

#### ◇ Alarm Contents

Blink Count	Function	Operating Condition
2	Overheat Protection	When the temperature inside the driver exceeds 85°C
	Overload	When the accumulated value for the time that the load torque exceeds the maximum torque exceeds the overload detection time (Initial Value: 5 sec.)
	Overspeed	When the motor output shaft speed exceeds 4500 r/min
	Command Pulse Error	When an error has occurred for the command pulse value
3	Overvoltage Protection	When the primary voltage of the driver's inverter exceeds the upper limit value
	Undervoltage	When the primary voltage of the driver's inverter has fallen below the lower limit
4	Overflow during All Windings On	When the positioning deviation has exceeded the overflow rotation amount (Initial value: 3 rotations)
	Overflow during All Windings Off	When all winding on was performed even though the positioning deviation during all windings off was above the permissible value (Initial Value: 100 rotations min.)
7	Operating Data Error	When a return-to-electrical home operation was performed when an operating data error warning occurred
	Electronic Gear Setting Error	When the resolution set by the electronic gear is outside the range of the specifications
8	Sensor Error during Operation	When an abnormality has occurred in a sensor while the actuator is rotating
	Sensor Error during Initialization	When the main power supply was turned on before the motor cable was connected to the driver
	Initial Rotor Revolution Error	When the main power supply was turned on while the actuator was rotating
9	Motor Combination Error	When an actuator that cannot be combined with the other components was connected
	EEPROM Error	When an actuator control parameter is damaged

### 2 Current Setting Switch

Indication	Switch Name	Function
CURRENT	Current Setting Switch	Sets the current value during operation. Used to limit the torque or temperature rise. The current value is set with a ratio (%) relative to the rated output current value. Factory Setting: F

### 3 Velocity Filter Setting Switch

Indication	Switch Name	Function
V-FIL	Velocity Filter Setting Switch	<p>Adjust the responsiveness of the actuator. Adjust to suppress the vibration of the actuator or make starting and stopping smoother. The min. value of the velocity filter is "0" and the max. value is "F". Factory Setting: 1</p>

#### 4 | Function Switch/Setting Switch (SW1)

Indication	Switch Name	Function
4	Resolution Select Switch "D0/D1" "CS0/CS1"	Sets the resolution per one rotation of the output table. "4: OFF" "3: OFF" → 18000 P/R (0.02/step) [Factory setting] "4: OFF" "3: ON" → 180000 P/R (0.002/step) "4: ON" "3: OFF" → 9000 P/R (0.04/step) "4: ON" "3: ON" → 90000 P/R (0.004/step)
3		
2	Control Mode Select Switch "NORM/CCM"	Switches the control mode from normal mode to current control mode. When set to current control mode, the synchronization of the actuator is lost, but the noise and vibration is reduced. "OFF": Normal mode [Factory setting] "ON": Current control mode
1	Pulse Input Mode Select Switch "2P/1P"	Switches the pulse input mode between 1-pulse input mode and 2-pulse input mode. "OFF": 2-pulse input mode [Factory setting] "ON": 1-pulse input mode

#### 5 | I/O Signal Connector (CN5, 36 pins)

Indication	I/O	Pin No.	Code	Signal Name
CN5	Output power	1	—	—
		2	GND	Ground Connection
		3	ASG+	A-Phase Pulse Output Signal (Line driver)
		4	ASG—	
		5	BSG+	B-Phase Pulse Output Signal (Line driver)
		6	BSG—	
		7	TIM1+	Timing Output (Line driver)
		8	TIM1—	
		9	ALM+	Alarm Output
		10	ALM—	
		11	WNG+	Warning Output
		12	WNG—	
		13	END+	Positioning Completion Output
		14	END—	
		15	READY+/ALO+*1	Operation Ready Output/Alarm Code Output 0*1
		16	READY—/ALO—*1	
		17	TLC+/AL1+*1	Torque Limiting Output/Alarm Code Output 1*1
		18	TLC—/AL1—*1	
		19	TIM2+/AL2+*1	Timing Output (Open collector)/Alarm Code Output 2*1
		20	TIM2—/AL2—*1	
		21	GND	Ground Connection
	Input	22	IN—COM	Common for Input Signals
		23	C—ON*2	All Windings On Input*2
		24	CLR/ALM—RST	Deviation Counter Clear Input/Alarm Reset Input
		25	CCM	Current Control Mode On Input
		26	CS	Resolution Select Input
		27	—	—
		28	RETURN	Return To Electrical Home Operation
		29	P—RESET	Position Reset Input
		30	FREE	Excitation Off
		31	CW+/PLS+	CW Pulse Input/Pulse Input (+5 V/line driver)
		32	CW—/PLS—	
		33	CW+24/PLS+24 V	CW Pulse Input/Pulse Input (+24 V)
		34	CCW+24/DIR+24 V	CCW Pulse Input/Rotation Direction Input (+24 V)
		35	CCW+/DIR+	CCW Pulse Input/Rotation Direction Input (+5 V/line driver)
		36	CCW—/DIR—	

\*1 Enabled when the settings are changed with the separately-sold control module (**OPX-2A**) or data setting software (**MEXE02**).

\*2 The initial value for the all windings on input is normally open contact. When operating the motor, be sure to turn the all windings on input ON. When the all windings on input is not used, set the input logic to normally close contact in the separately-sold control module (**OPX-2A**) or data setting software (**MEXE02**).

#### Note

- The rotation directions of the driver input signals (CW and CCW) are opposite the actual rotation directions of the output table.  
When the CW pulse signal is input, the output table rotates in the counterclockwise direction.  
When the CCW signal is input, the output table will rotate in the clockwise direction.

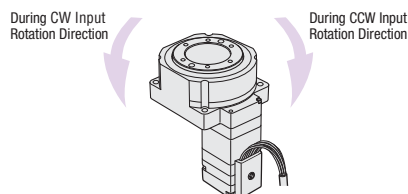

- The I/O signals of the **DGII** Series are not compatible with the **DG** Series.  
Connecting a **DG** Series pinout may damage the driver. Be sure to use the **DGII** Series pinout when wiring.

# Connection and Operation (Pulse input type AC power supply input)

## Names and Functions of Driver Parts

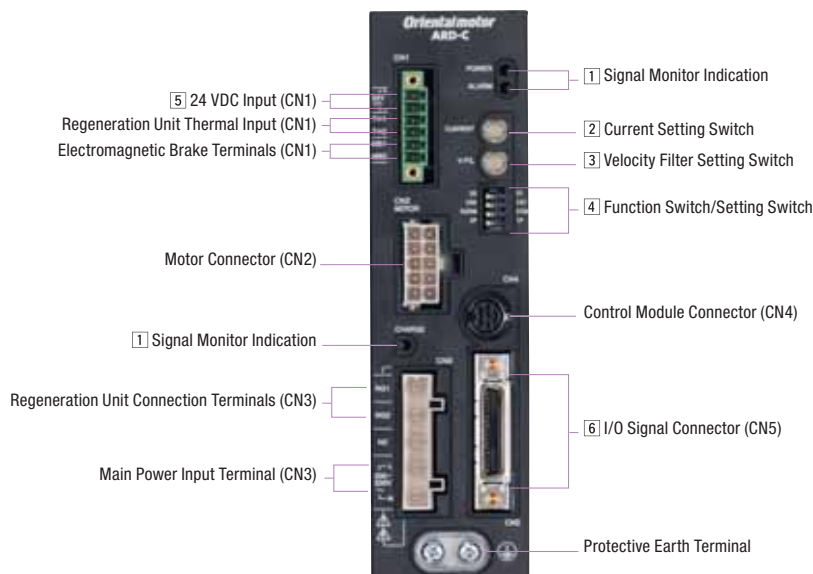

### 1 Signal Monitor Indication

#### ◇ LED Indicator

Indication	Color	Function	Lighting Condition
POWER	Green	Power Supply Indication	When the main power supply or 24 VDC power supply is input
ALARM	Red	Alarm Indication	When a protective function is activated (blinking)
CHARGE	Red	Power Supply Indication	When the main power supply is input

#### ◇ Alarm Contents

Blink Count	Function	Operating Condition
2	Overheat Protection	When the temperature inside the driver exceeds 85°C
	Overload	When the accumulated value for the time that the load torque exceeds the maximum torque exceeds the overload detection time (Initial Value: 5 sec.)
	Overspeed	When the motor output shaft speed exceeds 4500 r/min
	Command Pulse Error	When an error has occurred for the command pulse value
3	Regeneration Unit Overheat	When the signal thermal protector for the regeneration unit has been activated
	Overvoltage Protection	When the primary voltage of the driver's inverter exceeds the upper limit value
	Main Power Supply Error	When the main power supply has been cut off while operation command are being input to the driver
4	Undervoltage	When the primary voltage of the driver's inverter has fallen below the lower limit
	Overflow during All Windings On	When the positioning deviation has exceeded the overflow rotation amount (Initial value: 3 rotations)
	Overflow during All Windings Off	When all winding on was performed even though the positioning deviation during all windings off was above the permissible value (Initial Value: 100 rotations min.)
5	Overcurrent Protection	An excessive current has flowed through the inverter power component inside the driver
	Power-Supply Circuit Error	When an actuator power line is disconnected
7	Operating Data Error	When a return-to-electrical home operation was performed when an operating data error warning occurred
	Electronic Gear Setting Error	When the resolution set by the electronic gear is outside the range of the specifications
8	Sensor Error during Operation	When an abnormality has occurred in a sensor while the actuator is rotating
	Sensor Error during Initialization	When the main power supply was turned on before the motor cable was connected to the driver
	Initial Rotor Revolution Error	When the main power supply was turned on while the actuator was rotating
9	Motor Combination Error	When an actuator that cannot be combined with the other components was connected
	EEPROM Error	When an actuator control parameter is damaged

### 2 Current Setting Switch

Indication	Switch Name	Function
CURRENT	Current Setting Switch	Sets the current value during operation. Used to limit the torque or temperature rise. The current value is set with a ratio (%) relative to the rated output current value. Factory Setting: F

### 3 Velocity Filter Setting Switch

Indication	Switch Name	Function
V-FIL	Velocity Filter Setting Switch	<p>Adjust the responsiveness of the actuator. Adjust to suppress the vibration of the actuator or make starting and stopping smoother. The min. value of the velocity filter is "0" and the max. value is "F". Factory Setting: 1</p> <p>Difference in Characteristics Due to Velocity Filter</p>

#### 4] Function Switch/Setting Switch

Indication	Switch Name	Function
D0/D1	Resolution Select Switch	Sets the resolution per one rotation of the output table. "D0" "CS0" → 18000 P/R (0.02°/step) [Factory setting] "D0" "CS1" → 180000 P/R (0.002°/step)
CS0/CS1		"D1" "CS0" → 9000 P/R (0.04°/step) "D1" "CS1" → 90000 P/R (0.004°/step)
NORM/CCM	Control Mode Select Switch	Switches the control mode from normal mode to current control mode. When set to current control mode, the synchronization of the actuator is lost, but the noise and vibration is reduced. "NORM": Normal mode [Factory setting] "CCM": Current control mode
2P/1P	Pulse Input Mode Select Switch	Switches the pulse input mode between 1-pulse input mode and 2-pulse input mode. "2P": 2-pulse input mode [Factory setting] "1P": 1-pulse input mode

#### 5] 24 VDC Input/Regeneration Unit Thermal Input/Electromagnetic Brake Terminals (CN1)

Indication	I/O	Terminal Name	Content
24V+		24 VDC Power Input Terminal+	To separate the main power supply and control power supply, connect the power supplies here. The control power supply is not mandatory. When using an electromagnetic brake actuator, connect it as the power supply for the electromagnetic brake.
24V-		24 VDC Power Input Terminal-	
TH1	Input	Regeneration Unit Thermal Input Terminal	Connect the accessory (sold separately) regeneration unit ( <b>RGB100</b> ). When not connecting a regeneration unit, short these 2 terminals to each other.
TH2		Regeneration Unit Thermal Input Terminal	
MB1	Output power	Electromagnetic Brake Terminal -	For an electromagnetic brake actuator, connect the electromagnetic brake line here.
MB2		Electromagnetic Brake Terminal +	

#### 6] I/O Signal Connector (CN5, 36 pins)

Indication	I/O	Pin No.	Code	Signal Name
CN5	Output power	1	-	-
		2	GND	Ground Connection
		3	ASG+	A-Phase Pulse Output Signal (Line driver)
		4	ASG-	
		5	BSG+	B-Phase Pulse Output Signal (Line driver)
		6	BSG-	
		7	TIM1+	Timing Output (Line driver)
		8	TIM1-	
		9	ALM+	Alarm Output
		10	ALM-	
		11	WNG+	Warning Output
		12	WNG-	
		13	END+	Positioning Completion Output
		14	END-	
		15	READY+/ALO+*1	Operation Ready Output/Alarm Code Output 0*1
		16	READY-/ALO-*1	
		17	TLC+/AL1+*1	Torque Limiting Output/Alarm Code Output 1*1
		18	TLC-/AL1-*1	
		19	TIM2+/AL2+*1	Timing Output (Open collector)/Alarm Code Output 2*1
		20	TIM2-/AL2-*1	
		21	GND	Ground Connection
	Input	22	IN-COM	Common for Input Signals
		23	C-ON*2	All Windings On Input*2
		24	CLR/ALM-RST	Deviation Counter Clear Input/Alarm Reset Input
		25	CCM	Current Control Mode On Input
		26	CS	Resolution Select Input
		27	-	-
		28	RETURN	Return To Electrical Home Operation
		29	P-RESET	Position Reset Input
		30	FREE	Excitation Off and Electromagnetic Brake Release
		31	CW+/PLS+	CW Pulse Input/Pulse Input (+5 V/line driver)
		32	CW-/PLS-	
		33	CW+24/PLS+24 V	CW Pulse Input/Pulse Input (+24 V)
		34	CCW+24/DIR+24 V	CCW Pulse Input/Rotation Direction Input (+24 V)
		35	CCW+/DIR+	CCW Pulse Input/Rotation Direction Input (+5 V/line driver)
		36	CCW-/DIR-	

\*1 Enabled when the settings are changed with the separately-sold control module (**OPX-2A**) or data setting software (**MEXE02**).

\*2 The initial value for the all windings on input is normally open contact. When operating the motor, be sure to turn the all windings on input ON. When the all windings on input is not used, set the input logic to normally close contact in the separately-sold control module (**OPX-2A**) or data setting software (**MEXE02**).

#### Note

- The rotation directions of the driver input signals (CW and CCW) are opposite the actual rotation directions of the output table.  
When the CW pulse signal is input, the output table rotates in the counterclockwise direction.  
When the CCW signal is input, the output table will rotate in the clockwise direction.

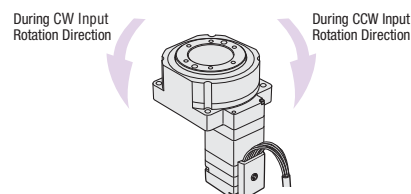

- The I/O signals of the **DGII** Series are not compatible with the **DG** Series.  
Connecting a **DG** Series pinout may damage the driver. Be sure to use the **DGII** Series pinout when wiring.

● Connection Diagram (For AC power supply input)

◇ Connections with Peripheral Equipment

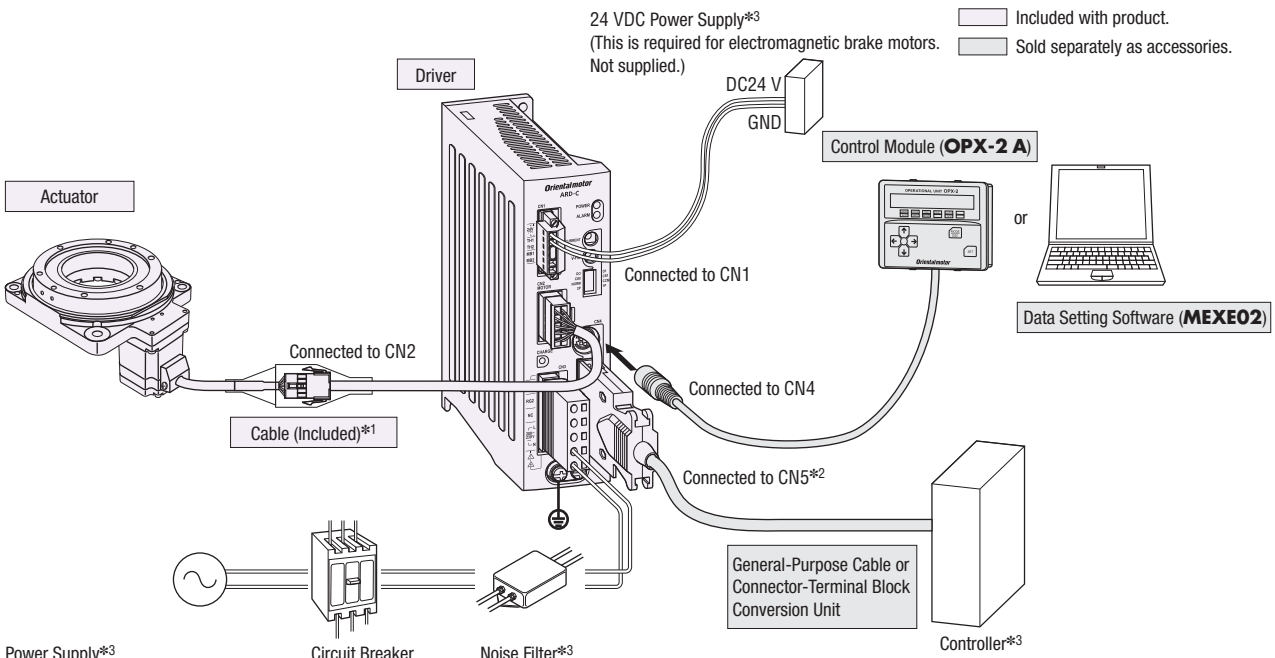

Power Supply\*3  
Single-Phase 100-115 VAC 50/60 Hz  
Single-Phase 200-230 VAC 50/60 Hz

Circuit Breaker  
or Ground Fault Interrupter\*3

\*1 1 m, 2 m or 3 m cables are included. If you need cables longer than 3 m or flexible cables, select appropriate cables from the accessories (sold separately).  
Keep the wiring distance between the actuator and driver to 30 m max.

\*2 The control I/O connector (CN5) is included with the product, but you can also purchase an accessory general-purpose cable or connector – terminal block conversion unit (sold separately). Choose one or the other.

\*3 Not supplied.

◇ Connecting the Main Power Supply

Prepare the following cable for the power supply lines.

Single-Phase 100-115 VAC: Three-Core Cable [AWG16 to 14 (1.25 to 2.0 mm<sup>2</sup>)]

Single-Phase 200-230 VAC: Three-Core Cable [AWG16 to 14 (1.25 to 2.0 mm<sup>2</sup>)]

Three-Phase 200-230 VAC: Four-Core Cable [AWG16 to 14 (1.25 to 2.0 mm<sup>2</sup>)]

● Single-Phase 100-115 VAC/Single-Phase 200-230 VAC

● Three-Phase 200-230 VAC

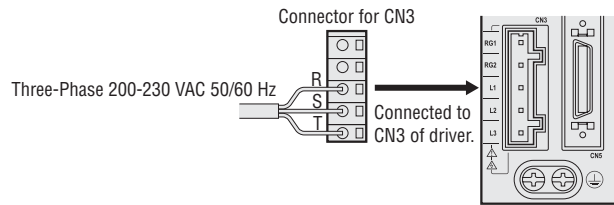
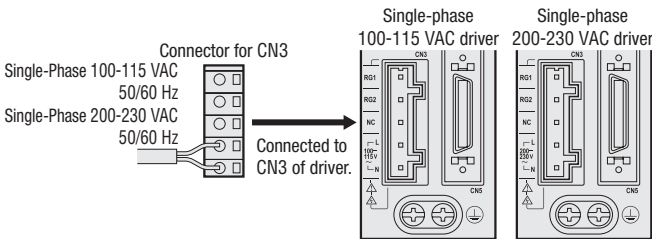

◇ Connecting the Control Power Supply

To separate the main power supply and control power supply, prepare a 24 VDC power supply.

The control power supply is not mandatory.

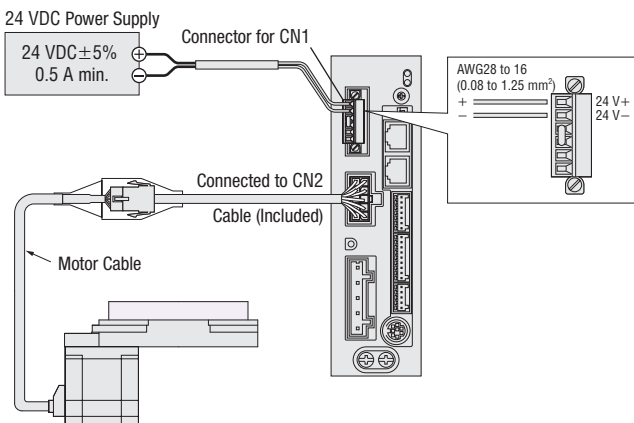

◇ Connecting the Electromagnetic Brake

Prepare a 24 VDC power supply.

The main power supply and control power supply are separated in this case too.

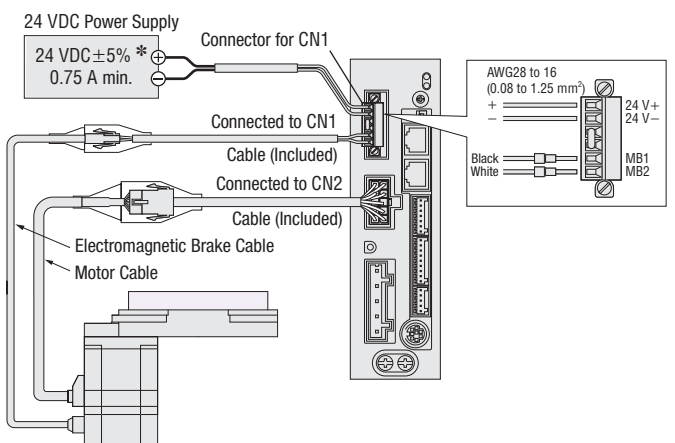

\*If the wiring distance is extended to 20 m min. using an accessory cable (sold separately), the 24 VDC±4% specification applies.

Lineup  
Features  
How to Read Specifications Table  
System Configuration  
Product Line  
Specifications and Characteristics  
Dimensions  
Connection and Operation  
Combination List  
Accessories

◇ Connection with Programmable Controller (Common to DC power supply input and AC power supply input)

● Connection Diagram for Connection with Current Sink Output Circuit

When the Pulse Input is the Line Driver

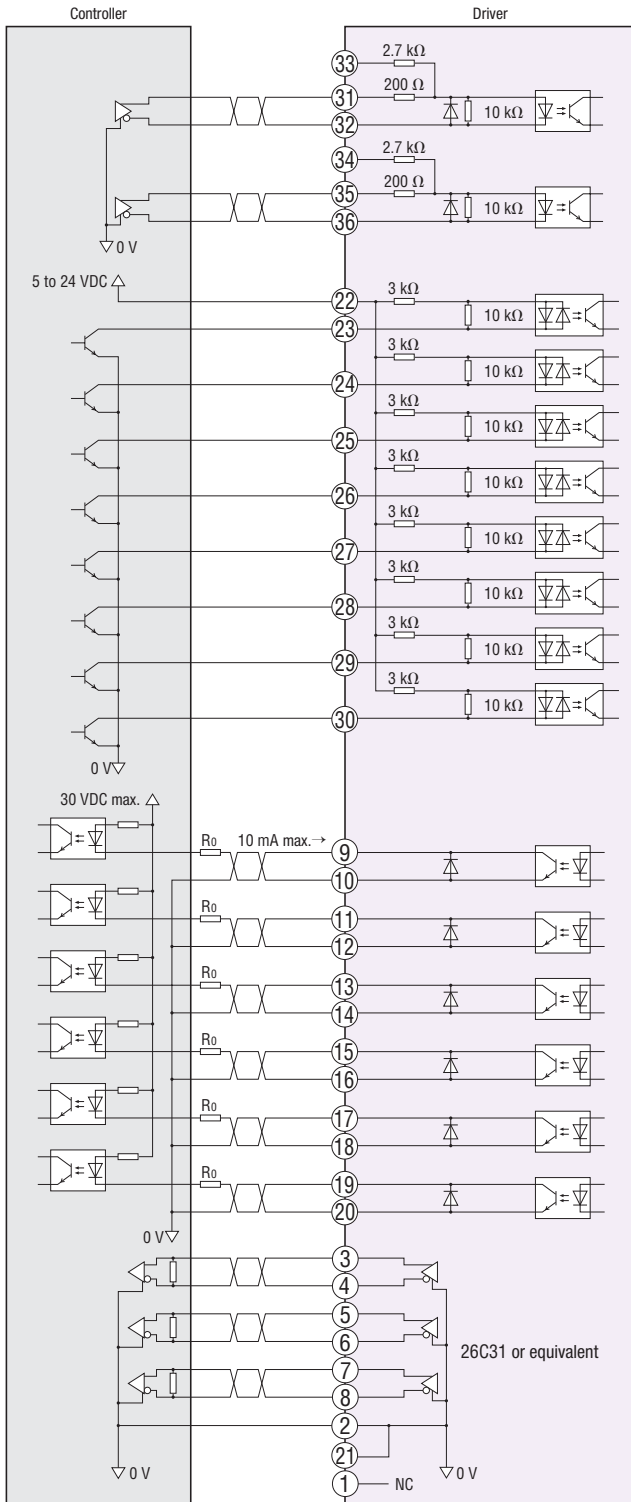

When the Pulse Input is 5 V

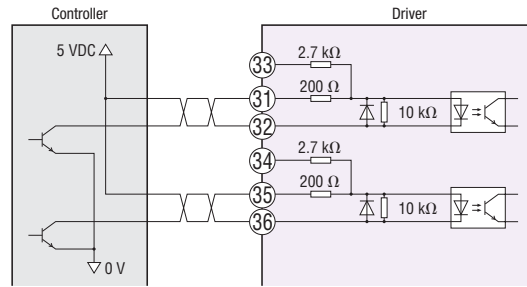

When the Pulse Input is 24 V

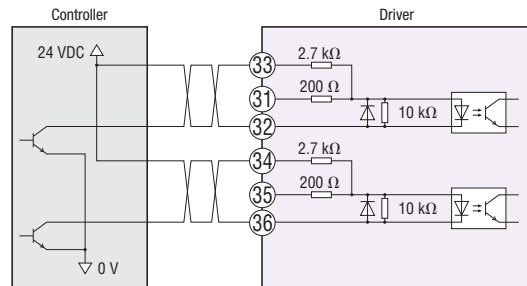

**Note**

- The I/O signals of the **DGII** Series are not compatible with the **DG** Series. Connecting a **DG** Series pinout may damage the driver. Be sure to use the **DGII** Series pinout when wiring.
- Use output signals 30 VDC max. When the current value exceeds 10 mA, connect the external resistor  $R_o$ .
- Connect a terminating resistor of 100 Ω min. between the line receiver inputs.
- For the control I/O signal lines (CN5), use a multi-core shielded twisted-pair wire [AWG28 to 24 (0.08 to 0.2 mm<sup>2</sup>)] and keep the wiring length as short as possible (no more than 2 m).
- Note that as the length of the pulse line increases, the maximum transmission frequency decreases.
- Provide a distance of 200 mm min. between the control I/O signal lines and power lines (power supply lines, motor lines and other large-current circuits).

◇ Connection with Programmable Controller (Common to DC power supply input and AC power supply input)

● Connection Diagram for Connection with Current Source Output Circuit

When the Pulse Input is the Line Driver

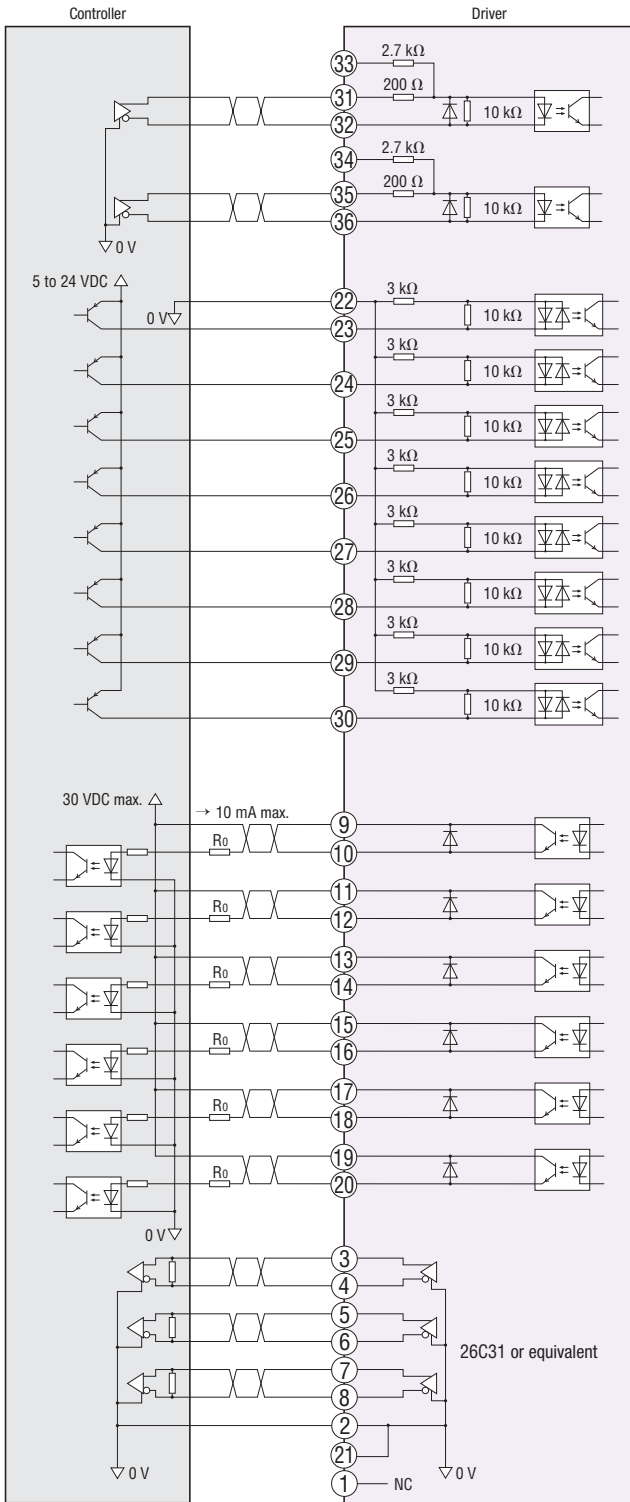

When the Pulse Input is 5 V

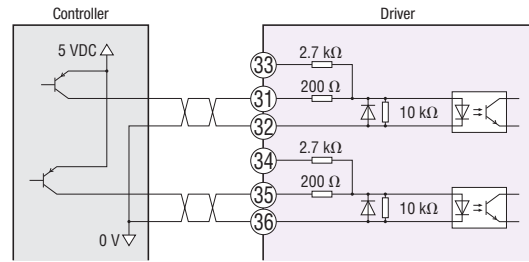

When the Pulse Input is 24 V

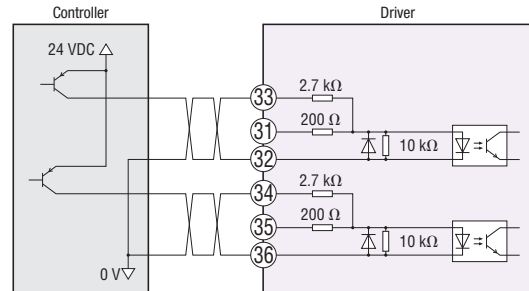

**Note**

- The I/O signals of the **DGII** Series are not compatible with the **DG** Series. Connecting a **DG** Series pinout may damage the driver. Be sure to use the **DGII** Series pinout when wiring.
- Use output signals 30 VDC max. When the current value exceeds 10 mA, connect the external resistor  $R_0$ .
- Connect a terminating resistor of 100 Ω min. between the line receiver inputs.
- For the control I/O signal lines (CN5), use a multi-core shielded twisted-pair wire [AWG28 to 24 (0.08 to 0.2 mm<sup>2</sup>)] and keep the wiring length as short as possible (no more than 2 m).
- Note that as the length of the pulse line increases, the maximum transmission frequency decreases.
- Provide a distance of 200 mm min. between the control I/O signal lines and power lines (power supply lines, motor lines and other large-current circuits).

## List of Actuator and Driver Combinations

Product names for actuator and driver combination products are shown below.

### Built-In Controller Type

Product Name	Actuator Product Name	Driver Product Name
<b>DG60-ARAK2</b> ◇	DGM60-ARAK	ARD-KD
<b>DG60-ARBK2</b> ◇	DGM60-ARBK	ARD-KD
<b>DG85R-ARAAD2</b> ◇	DGM85R-ARAC	ARD-AD
<b>DG85R-ARACD2</b> ◇		ARD-CD
<b>DG85R-ARBAD2</b> ◇	DGM85R-ARBC	ARD-AD
<b>DG85R-ARBCD2</b> ◇		ARD-CD
<b>DG130R-ARAAD2</b> ◇	DGM130R-ARAC	ARD-AD
<b>DG130R-ARACD2</b> ◇		ARD-CD
<b>DG130R-ARBAD2</b> ◇	DGM130R-ARBC	ARD-AD
<b>DG130R-ARBCD2</b> ◇		ARD-CD
<b>DG130R-ARMAD2</b> ◇	DGM130R-ARMC	ARD-AD
<b>DG130R-ARMCD2</b> ◇		ARD-CD
<b>DG200R-ARAAD2</b> ◇	DGM200R-ARAC	ARD-AD
<b>DG200R-ARACD2</b> ◇		ARD-CD
<b>DG200R-ARBAD2</b> ◇	DGM200R-ARBC	ARD-AD
<b>DG200R-ARBCD2</b> ◇		ARD-CD
<b>DG200R-ARMAD2</b> ◇	DGM200R-ARMC	ARD-AD
<b>DG200R-ARMCD2</b> ◇		ARD-CD

### Pulse Input Type

Product Name	Actuator Product Name	Driver Product Name
<b>DG60-ARAK2</b> ◇	DGM60-ARAK	ARD-K
<b>DG60-ARBK2</b> ◇	DGM60-ARBK	
<b>DG85R-ARAA2</b> ◇	DGM85R-ARAC	ARD-A
<b>DG85R-ARAC2</b> ◇		ARD-C
<b>DG85R-ARAS2</b> ◇		ARD-S
<b>DG85R-ARBA2</b> ◇	DGM85R-ARBC	ARD-A
<b>DG85R-ARBC2</b> ◇		ARD-C
<b>DG85R-ARBS2</b> ◇		ARD-S
<b>DG130R-ARAA2</b> ◇	DGM130R-ARAC	ARD-A
<b>DG130R-ARAC2</b> ◇		ARD-C
<b>DG130R-ARAS2</b> ◇		ARD-S
<b>DG130R-ARBA2</b> ◇	DGM130R-ARBC	ARD-A
<b>DG130R-ARBC2</b> ◇		ARD-C
<b>DG130R-ARBS2</b> ◇		ARD-S
<b>DG130R-ARMA2</b> ◇	DGM130R-ARMC	ARD-A
<b>DG130R-ARMC2</b> ◇		ARD-C
<b>DG130R-ARMS2</b> ◇		ARD-S
<b>DG200R-ARAA2</b> ◇	DGM200R-ARAC	ARD-A
<b>DG200R-ARAC2</b> ◇		ARD-C
<b>DG200R-ARAS2</b> ◇		ARD-S
<b>DG200R-ARBA2</b> ◇	DGM200R-ARBC	ARD-A
<b>DG200R-ARBC2</b> ◇		ARD-C
<b>DG200R-ARBS2</b> ◇		ARD-S
<b>DG200R-ARMA2</b> ◇	DGM200R-ARMC	ARD-A
<b>DG200R-ARMC2</b> ◇		ARD-C
<b>DG200R-ARMS2</b> ◇		ARD-S

● A number indicating the desired length of **1** (1 m), **2** (2 m) or **3** (3 m) for the cable included with the product is entered where the box ◇ is located within the product name.



# Accessories (Sold separately)

## Control Module RoHS

This enables you to perform operations such as setting the driver's internal parameters and setting or changing the data. It can also be used for operations such as speed and I/O monitoring, and teaching.

### Product Line

Product Name
<b>OPX-2A</b>

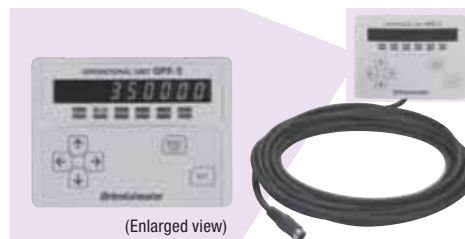

(Enlarged view)

### Dimensions (Unit = mm)

#### Control Module

Mass: 0.25 kg

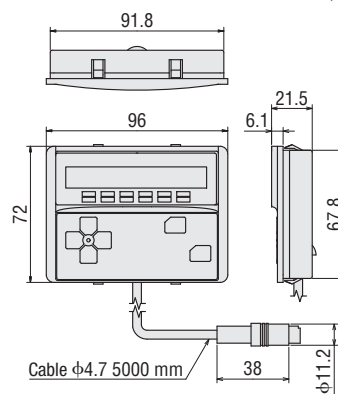

#### Panel Cut-Out for Control Module

(Installation plate thickness 1 to 3 mm)

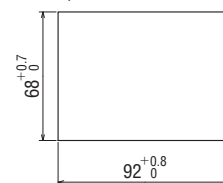

Lineup

Features

How to Read Specifications Table

System Configuration

Product Line

Specifications and Characteristics

Dimensions

Connection and Operation

Combination List

Accessories

# Data Setting Software Communication Cable RoHS

This communication cable is required for connecting to the computer on which the data setting software is installed.



## Product Line

Product Name
<b>CC05IF-USB</b>

## Connection between Computer and Driver

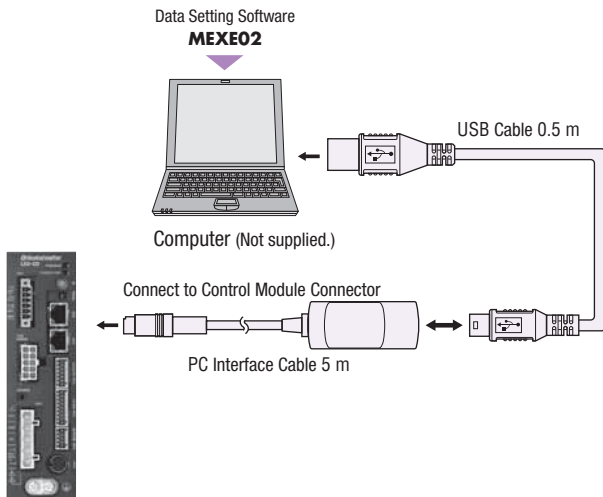

### Note

● To connect with the computer, the dedicated driver must be installed.

## Data Setting Software **MEXE02**

The data setting software can be downloaded from the Oriental Motor website.

Oriental Motor can also provide a CD-ROM of the data setting software.

For details, please inquire via the website or contact the nearest Oriental Motor sales office.

<http://www.orientalmotor.eu>

## Operating Environment

### Operating System (OS)

- Microsoft Windows 2000 Professional Service Pack 4  
Be sure to install Rollup 1 provided by Microsoft Corporation. You can check whether Rollup 1 has been installed in "Add or remove programs".

For the following operating systems, both the 32-bit (x86) edition and 64-bit (x64) edition are supported.

- Microsoft Windows XP Home Edition Service Pack 3
- Microsoft Windows XP Professional Service Pack 2
- Microsoft Windows XP Professional Service Pack 3\*
- Microsoft Windows Vista Home Basic Service Pack 2
- Microsoft Windows Vista Home Premium Service Pack 2
- Microsoft Windows Vista Business Service Pack 2
- Microsoft Windows Vista Ultimate Service Pack 2
- Microsoft Windows Vista Enterprise Service Pack 2
- Microsoft Windows 7 Starter Service Pack 1
- Microsoft Windows 7 Home Premium Service Pack 1
- Microsoft Windows 7 Professional Service Pack 1
- Microsoft Windows 7 Ultimate Service Pack 1
- Microsoft Windows 7 Enterprise Service Pack 1
- Microsoft Windows 8

\*32-bit (x86) edition only

### PC

Recommended CPU*1	Intel Core Processor 2 GHz min. (Must be compatible with OS)
Display	Video Adapter and Monitor with Resolution of XGA (1024×768) min.
Recommended Memory*1	32-bit (x86) Edition: 1 GB min. 64-bit (x64) Edition: 2 GB min.
Hard Disk*2	Free disk space of 30 MB min.
USB Port	USB 1.1 1 Port
Disk Device	CD-ROM Drive (Used for installation)

\*1 The operating conditions of the OS must be satisfied.

\*2 Microsoft .NET Framework 4 Client Profile is required for **MEXE02**. If it is not installed, it will be installed automatically. An additional max. of 1.5 GB of free space may be required.

### Note

● The required memory and hard disk space may vary depending on your system environment.

● Windows and Windows Vista are registered trademarks of the Microsoft Corporation in the United States and other countries.

# Home Sensor Sets RoHS

A home sensor set, which consists of a photomicro sensor, cable type connector, sensor installation bracket, shield plate and installation screws, is provided to facilitate easy return-to-home operation.

Since the sensor set comes with all the parts required for the return-to-home operation, you will spend less time designing, fabricating and procuring parts relating to sensor installation. Installation is very easy, so you can start using the sensor right away.

## Product Line

Product Name	Sensor Output	Applicable Product
<b>PADG-SA</b>	NPN	<b>DG60</b>
<b>PADG-SAY</b>	PNP	
<b>PADG-SB</b>	NPN	<b>DG85</b>
<b>PADG-SBY</b>	PNP	<b>DG130</b> <b>DG200</b>

PADG-SB

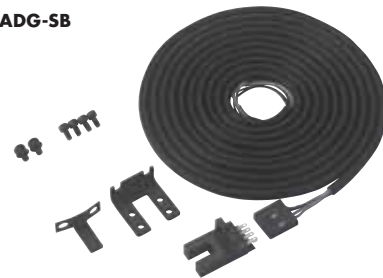

## Specifications

### NPN Type

Sensor Product Name	<b>DG60</b> : EE-SX672A (Made by OMRON) <b>DG85, DG130, DG200</b> : EE-SX673A (Made by OMRON)
Power Supply Voltage	5 to 24 VDC±10% Ripple (P-P) 10% max.
Current Consumption	35 mA max.
Control Output	NPN Open-Collector Output 5 to 24 VDC 100 mA max. Residual Voltage 0.8 V max. (Load current of 100 mA)
Indicator LED	Detection Display (Red)
Sensor Logic	Normally Open/Normally Closed (Selectable, depending on connection)

### PNP Type

Sensor Product Name	<b>DG60</b> : EE-SX672R (Made by OMRON) <b>DG85, DG130, DG200</b> : EE-SX673R (Made by OMRON)
Power Supply Voltage	5 to 24 VDC±10% Ripple (P-P) 10% max.
Current Consumption	30 mA max.
Control Output	PNP Open-Collector Output 5 to 24 VDC 50 mA max. Residual Voltage 1.3 V max. (Load current of 50 mA)
Indicator LED	Detection Display (Red)
Sensor Logic	Normally Open/Normally Closed (Selectable, depending on connection)

## Installing the Home Sensor Set

Be aware of the following points when installing the accessory home sensor set.

- Set the operating conditions so that the operating ambient temperature stays at 40°C max. and the surface temperature of the actuator motor stays at 90°C max.
- When performing return-to-home operation using the back shaft of the motor, a separate sensor, installation bracket and other necessary parts should be provided.

## When Extending the Sensor Line

Use shielded cable when extending the sensor line 2 m min. The shielded cable must be grounded.

## Sensor Installation Dimensions (Unit = mm)

### DG60

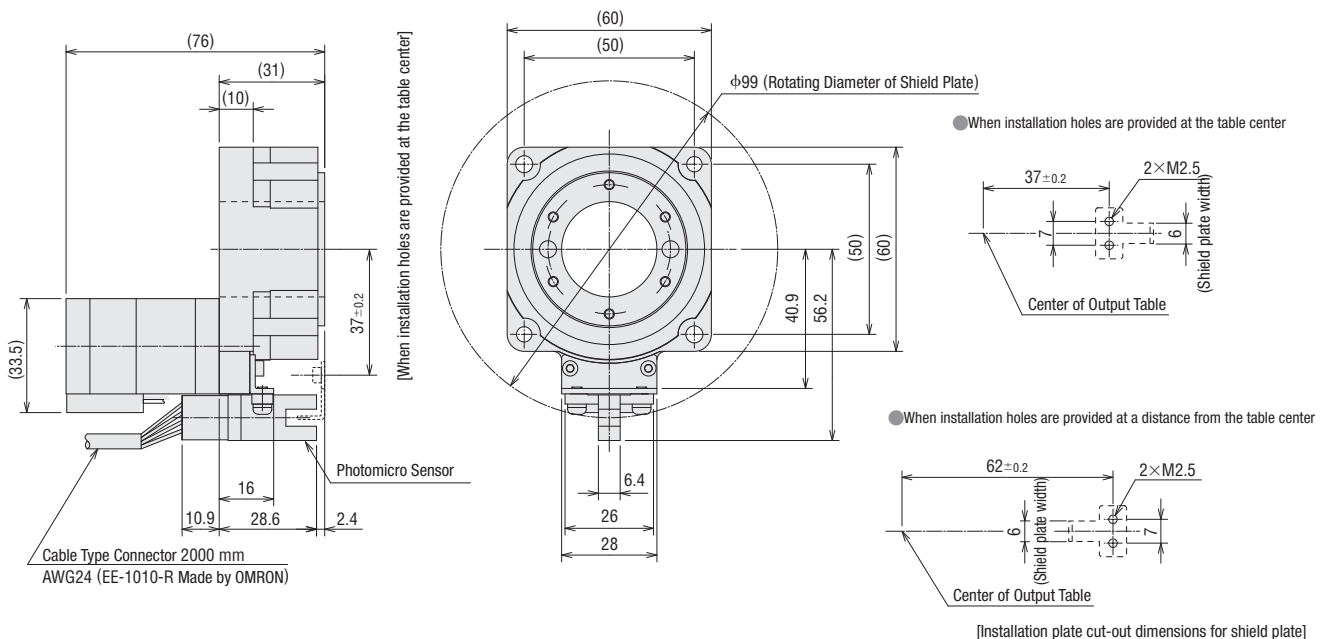

**DG85**

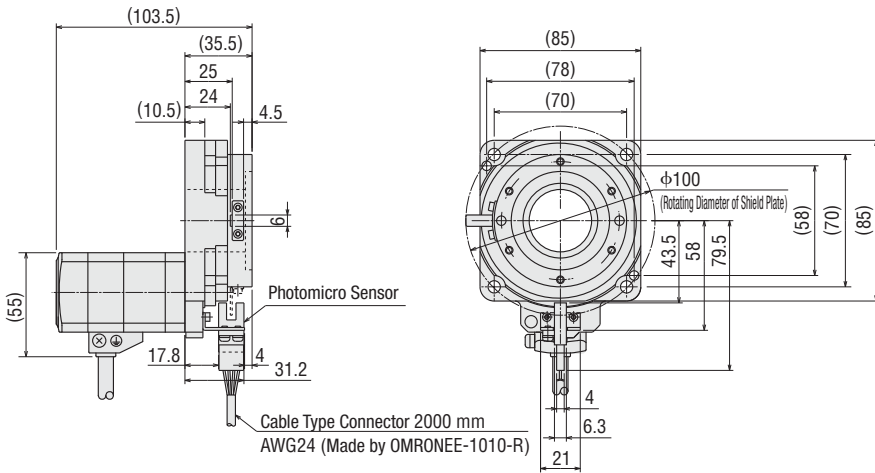

**DG130**

Actuator Product Name: DGM130R-ARAC

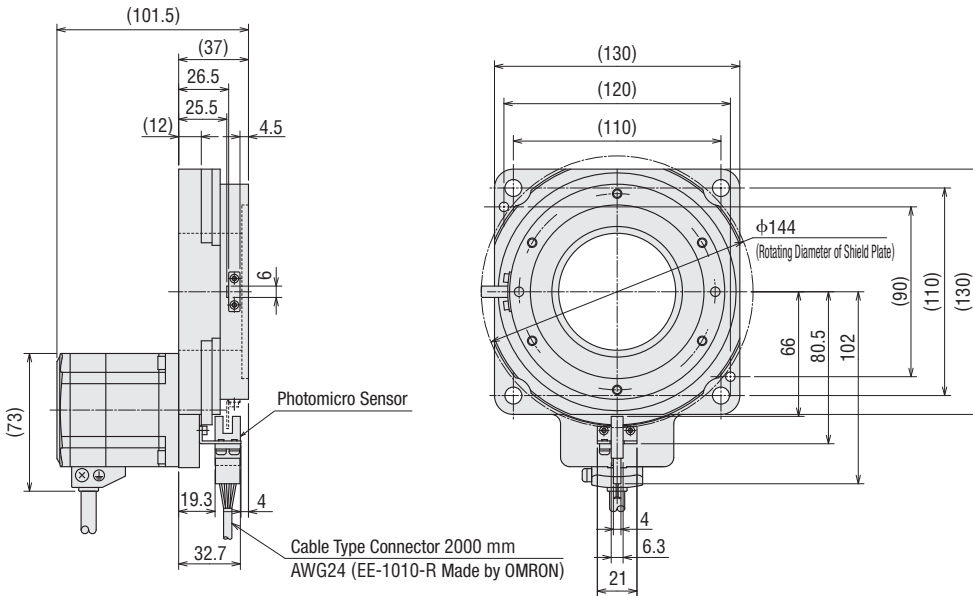

**DG200**

Actuator Product Name: DGM200R-ARAC

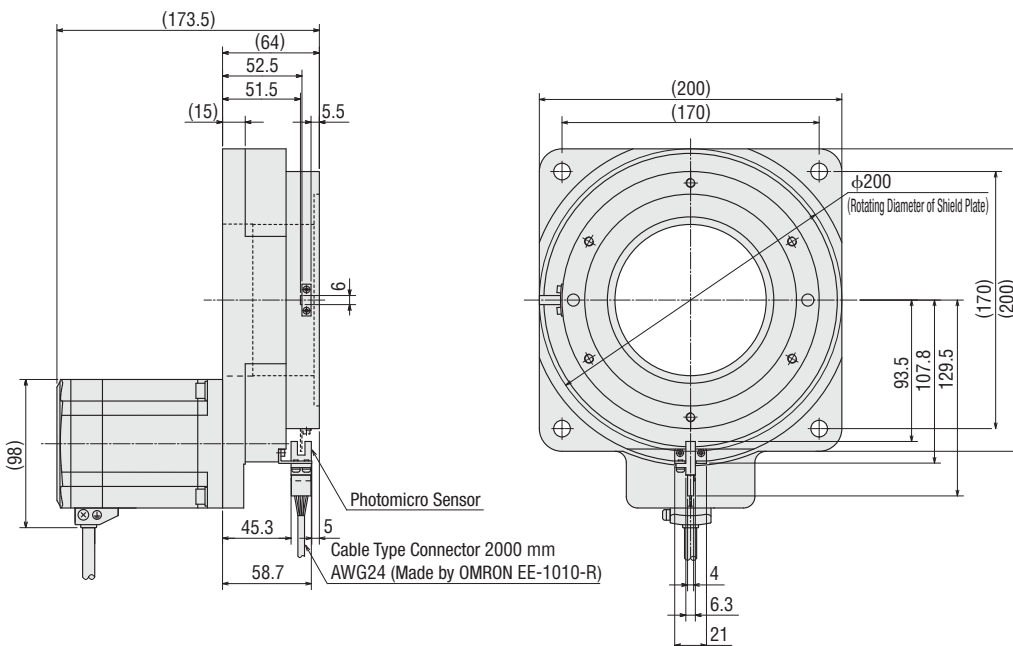

## Wiring the Sensor

### NPN Type

Keep the power-supply voltage between 5 VDC and 24 VDC.  
 Keep the current value of 100mA max.  
 When the current exceeds 100mA, connect the external resistor R.  
 The GND of sensor power and power of external controller should be connected together.

#### <Pulse Input Type>

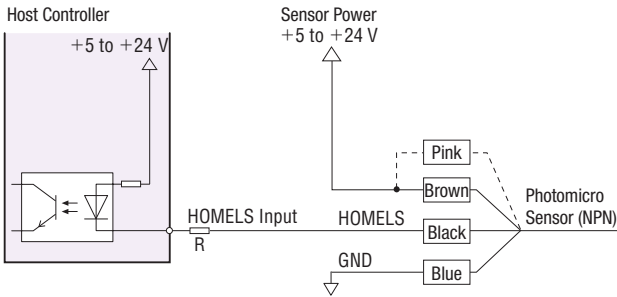

--- Connect the pink lead wire to the brown lead wire when the sensor logic is N.C. (normally closed).  
 The pink lead wire is not connected when the sensor logic is N.O. (normally open).

#### <Built-In Controller Type>

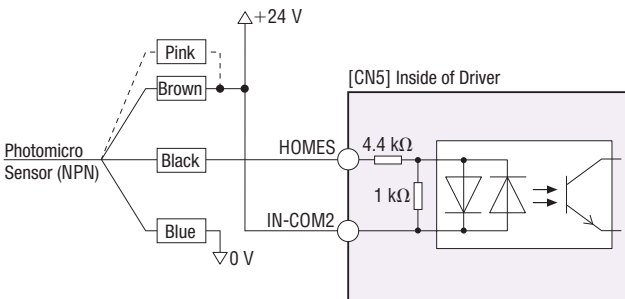

--- Connect the pink lead wire to the brown lead wire when the sensor logic is N.C. (normally closed).  
 The pink lead wire is not connected when the sensor logic is N.O. (normally open).

### PNP Type

Keep the power-supply voltage between 5 VDC and 24 VDC.  
 Keep the current value of 50mA max.  
 When the current exceeds 50 mA, connect the external resistor R.

#### <Pulse Input Type>

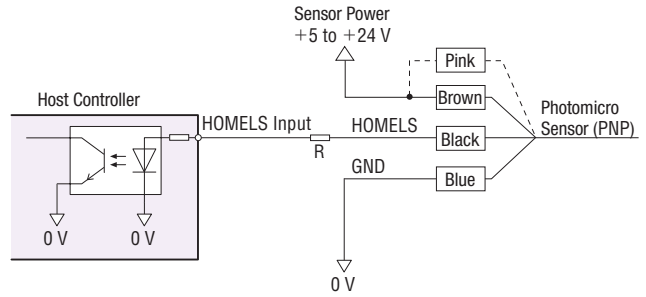

--- Connect the pink lead wire to the brown lead wire when the sensor logic is N.C. (normally closed).  
 The pink lead wire is not connected when the sensor logic is N.O. (normally open).

#### <Built-In Controller Type>

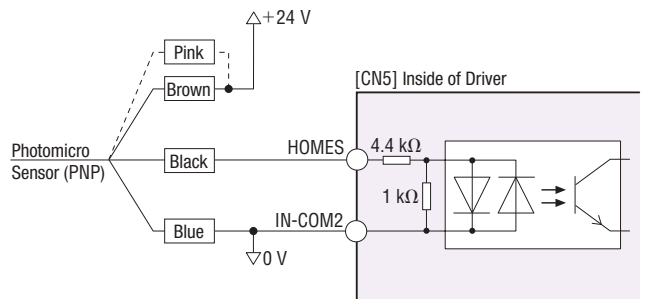

--- Connect the pink lead wire to the brown lead wire when the sensor logic is N.C. (normally closed).  
 The pink lead wire is not connected when the sensor logic is N.O. (normally open).

# Connection Cable Sets (RoHS), Flexible Connection Cable Sets (RoHS) Extension Cable Sets (RoHS), Flexible Extension Cable Sets (RoHS)

The **DGII** Series comes with a cable of 1 m, 2 m or 3 m for the connection between the actuator and driver.  
 When the distance between the actuator and driver is extended to 3 m or longer, a connection cable set or extension cable set must be used.  
 Use a flexible connection cable set or flexible extension cable set if the cable will be bent repeatedly.

## System Configuration

### When Connecting the Actuator and Driver without Using an Included Cable

- Use a connection cable set.
- Use a flexible connection cable set if the cable will be bent.

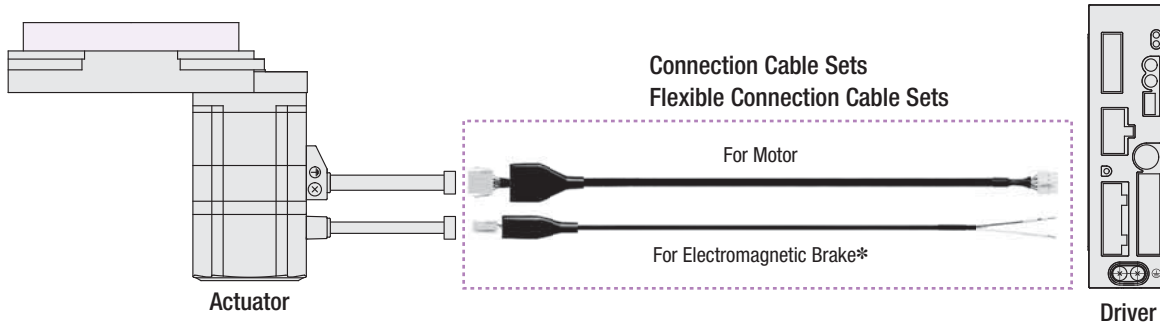

### When Extending the Distance between the Actuator and the Driver Using an Included Cable

- Use an extension cable set and connect it to the included cable.
- Use an flexible extension cable set added if the cable will be bent.

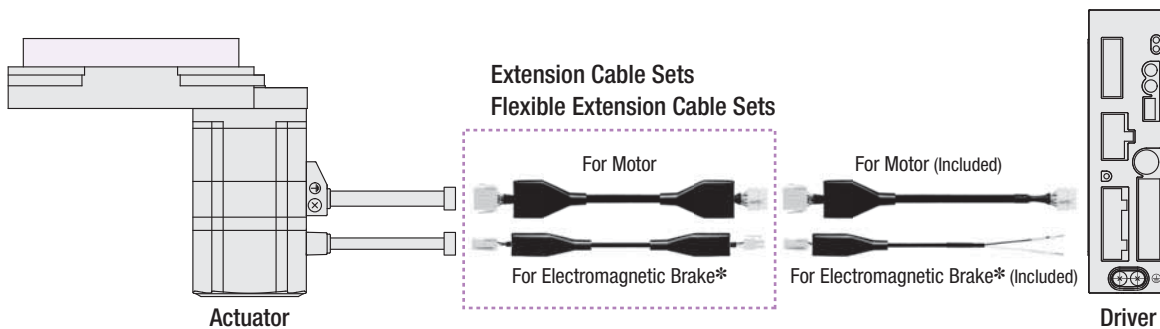

\*Cables for electromagnetic brake are for use when using the electromagnetic brake type.

**Note**

- Keep the overall cable length 30 m max. when using an extension cable set or a flexible extension cable set to connect with a cable included with the **DGII** Series.

# Connection Cable Sets (RoHS), Flexible Connection Cable Sets (RoHS)

## Product Line

### Connection Cable Sets

◇ For Single Shaft, Double Shaft



Cables for DC Power Supply Input Motors

Product Name	Length L (m)
CC050VA2F2	5
CC070VA2F2	7
CC100VA2F2	10
CC150VA2F2	15
CC200VA2F2	20
CC300VA2F2	30



Cables for AC Power Supply Input Motors

Product Name	Length L (m)
CC050VAF	5
CC070VAF	7
CC100VAF	10
CC150VAF	15
CC200VAF	20
CC300VAF	30

◇ For Electromagnetic Brake Type Motor



Cable for Motor



Cable for Electromagnetic Brake

Product Name	Length L (m)
CC050VAFB	5
CC070VAFB	7
CC100VAFB	10
CC150VAFB	15
CC200VAFB	20
CC300VAFB	30

### Flexible Connection Cable Sets

◇ For Single Shaft, Double Shaft



Cables for DC Power Supply Input Motors

Product Name	Length L (m)
CC010VA2R2	1
CC020VA2R2	2
CC030VA2R2	3
CC050VA2R2	5
CC070VA2R2	7
CC100VA2R2	10
CC150VA2R2	15
CC200VA2R2	20
CC300VA2R2	30



Cables for AC Power Supply Input Motors

Product Name	Length L (m)
CC010VAR	1
CC020VAR	2
CC030VAR	3
CC050VAR	5
CC070VAR	7
CC100VAR	10
CC150VAR	15
CC200VAR	20
CC300VAR	30

◇ For Electromagnetic Brake Type Motor



Cable for Motor



Cable for Electromagnetic Brake

Product Name	Length L (m)
CC010VARB	1
CC020VARB	2
CC030VARB	3
CC050VARB	5
CC070VARB	7
CC100VARB	10
CC150VARB	15
CC200VARB	20
CC300VARB	30

# Extension Cable Sets (RoHS), Flexible Extension Cable Sets (RoHS)

## Product Line

### Extension Cable Sets

◇ For Single Shaft, Double Shaft



Cables for DC Power Supply Input Motors

Product Name	Length L (m)
CC010VA2F2	1
CC020VA2F2	2
CC030VA2F2	3
CC050VA2F2	5
CC070VA2F2	7
CC100VA2F2	10
CC150VA2F2	15
CC200VA2F2	20



Cables for AC Power Supply Input Motors

Product Name	Length L (m)
CC010VAFT	1
CC020VAFT	2
CC030VAFT	3
CC050VAFT	5
CC070VAFT	7
CC100VAFT	10
CC150VAFT	15
CC200VAFT	20

◇ For Electromagnetic Brake Type Motor



Cable for Motor



Cable for Electromagnetic Brake

Product Name	Length L (m)
CC010VAFBT	1
CC020VAFBT	2
CC030VAFBT	3
CC050VAFBT	5
CC070VAFBT	7
CC100VAFBT	10
CC150VAFBT	15
CC200VAFBT	20

### Flexible Extension Cable Sets

◇ For Single Shaft, Double Shaft



Cables for DC Power Supply Input Motors

Product Name	Length L (m)
CC010VA2R2	1
CC020VA2R2	2
CC030VA2R2	3
CC050VA2R2	5
CC070VA2R2	7
CC100VA2R2	10
CC150VA2R2	15
CC200VA2R2	20



Cables for AC Power Supply Input Motors

Product Name	Length L (m)
CC010VART	1
CC020VART	2
CC030VART	3
CC050VART	5
CC070VART	7
CC100VART	10
CC150VART	15
CC200VART	20

◇ For Electromagnetic Brake Type Motor



Cable for Motor



Cable for Electromagnetic Brake

Product Name	Length L (m)
CC010VARBT	1
CC020VARBT	2
CC030VARBT	3
CC050VARBT	5
CC070VARBT	7
CC100VARBT	10
CC150VARBT	15
CC200VARBT	20

Lineup

Features

How to Read Specifications Table

System Configuration

Product Line

Specifications and Characteristics

Dimensions

Connection and Operation

Combination List

Accessories

## Dimension (Unit = mm)

### Connection Cable

#### ◇ Cables for DC Power Supply Input Motors

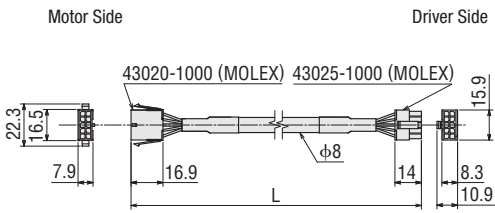

### Extension Cable

#### ◇ Cables for DC Power Supply Input Motors

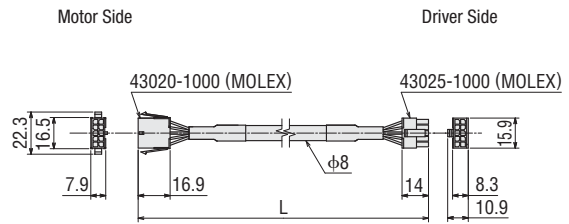

#### ◇ Cables for AC Power Supply Input Motors

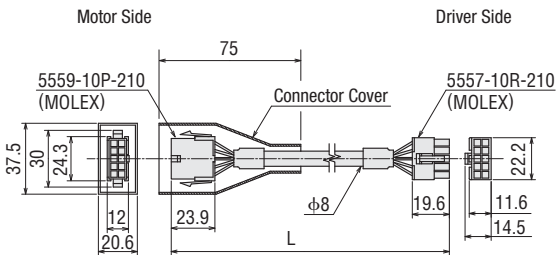

#### ◇ Cables for AC Power Supply Input Motors

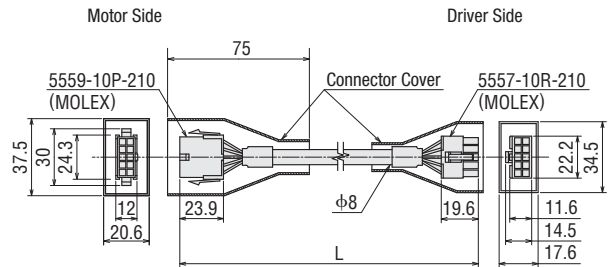

#### ◇ Cable for Electromagnetic Brake

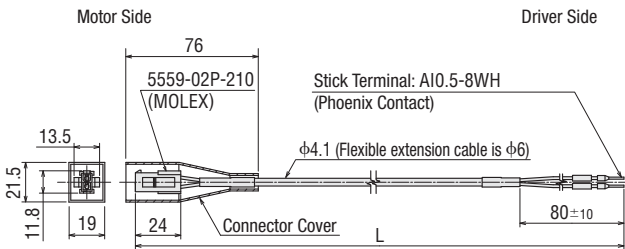

#### ◇ Cable for Electromagnetic Brake

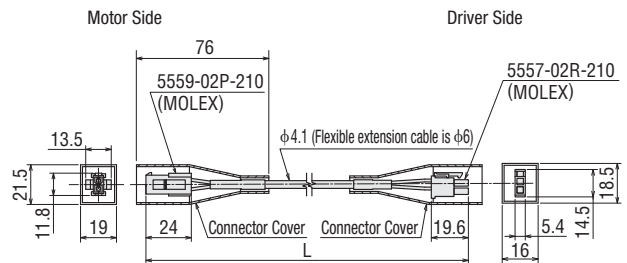

## Note on Use of Flexible Cable

① Do not allow the cable to bend at the cable connector.

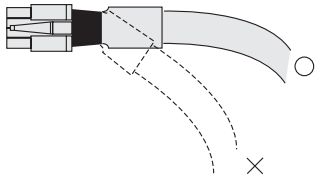

② For the bending radius, use at 6 times min. of the cable diameter.

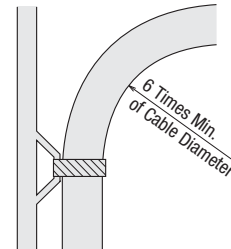

③ The cable from the actuator and the included cable are not for bending. If the motor cable is to be bent, bend it at the flexible cable.

#### • Flexible Connection Cable

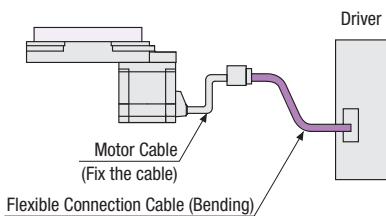

#### • Flexible Extension Cable

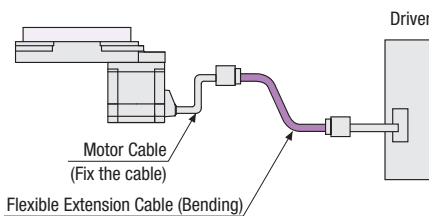



# Driver Cables

## General-Purpose Cables RoHS



This shielded cable has a half-pitch connector at one end of the cable for easy connecting to the driver.

### Note

- Note that as the length of the pulse line between the driver and controller increases, the maximum transmission frequency decreases.
- Install a connector that matches the controller you are using to the other end of the cable.

## Product Line

Product Line	Product Name	Applicable	Length L (m)
Straight	<b>CC36D1E</b>	Pulse Input Type For CN5 (36 pins)	1
	<b>CC36D2E</b>		2
Right Angle	<b>CC36D1AE</b>		1
	<b>CC36D2AE</b>		2

## Dimension (Unit = mm)

### CC36D1E, CC36D2E

Conductor: AWG28 (0.08 mm<sup>2</sup>)

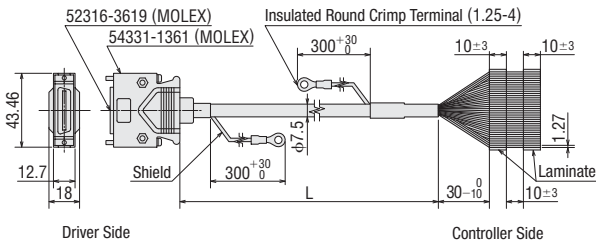

### CC36D1AE, CC36D2AE

Conductor: AWG28 (0.08 mm<sup>2</sup>)

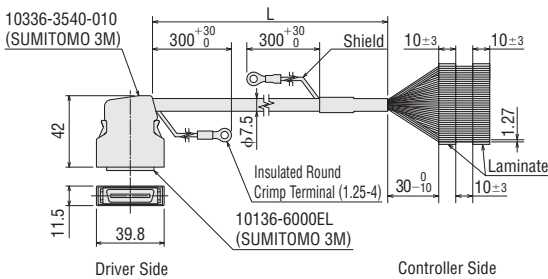

## Connector – Terminal Block Conversion Unit RoHS



CC36T10E

This is a conversion unit that connects a driver to a programmable controller using a terminal block.

- Includes a signal name plate for easy, one-glance identification of driver signal names
- DIN-Rail Installable
- Cable length: 1 m

## Product Line

Product Name	Applicable	Length m
<b>CC36T10E</b>	Pulse Input Type For CN5 (36 pins)	1

## Dimension (Unit = mm)

### CC36T10E

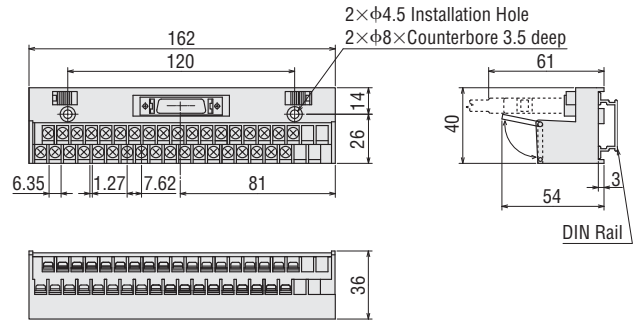

Terminal Block Pin No.

19	20	21	22	23	24	25	26	27	28	29	30	31	32	33	34	35	36
1	2	3	4	5	6	7	8	9	10	11	12	13	14	15	16	17	18

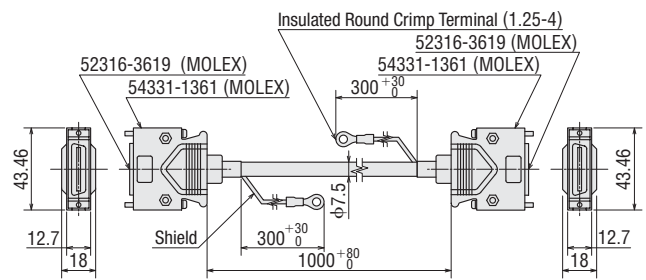

- Applicable Crimp Terminal
  - Terminal Screw Size: M3
  - Tightening Torque: 1.2 N·m
  - Applicable Min. Lead Wire: AWG22 (0.3 mm<sup>2</sup>)

### Note

- Round terminals cannot be used.

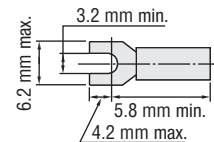

# Battery Set RoHS

Connect when using as an absolute backup system.

## Product Line

Product Name	Applicable
<b>BAT01B</b>	Built-In Controller Type



## Specifications

Item	Content
Battery Type	Sealed Nickel-Hydrogen Battery
Nominal Voltage	2.4 V
Rated Capacity	1900 mAh
Expected Life	Approx. 4 years *1
Charge Time	32 hours*1
Data Retention Period	Approx. 360 hours (Approx. 15 days)*1*2
Operating Ambient Temperature	0 to +40°C (non-freezing)
Operating Ambient Humidity	45 to 85% (non-condensing)

\*1 At an ambient temperature of 20°C

\*2 After the power supply is cut OFF with the battery fully charged Nickel-metal-hydride cell is used in this battery. Disposal of the used batteries is subject to each country's regulations on environmental control. Contact your nearest Oriental Motor office if you have any questions.

## Dimensions (Unit = mm)

Mass: 0.1 kg

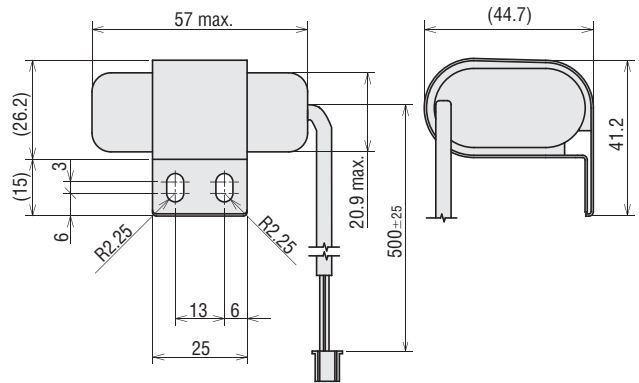

# RS-485 Communication Cables RoHS

This cable is used to link drivers in multi-axis operations. It also connects the network converter to the driver.



## Product Line

Applicable	Product Name	Length L (m)
Built-In Controller Type AC Power Supply Input	<b>CC002-RS4</b>	0.25
Built-In Controller Type DC Power Supply Input	<b>CC001-RS4</b> <b>CC002-RS4</b>	0.1 0.25

## Dimensions (Unit = mm)

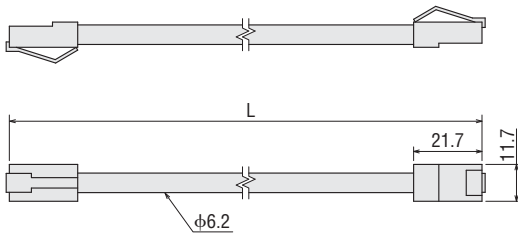

● Connection Example (The illustration below is for an AC power supply input.)

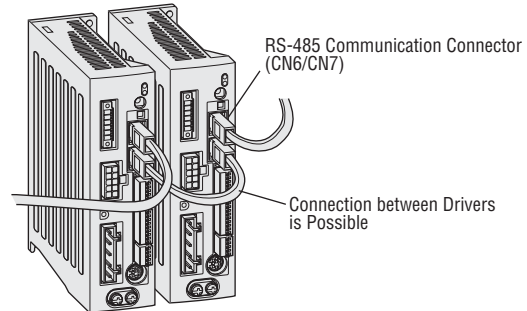

# Mounting Pedestal for DG Series RoHS

This is a useful mounting pedestal that enables the **DGII** Series to be used as a direct drive motor. Applications that require height and installation from the side can also be performed, expanding the range of available operations.

## Product Line

Product Name	DGII Series Applicable Products	
	Product Line	Product Name
<b>MDG60A</b>	Single Shaft	<b>DG60-ARA</b>
<b>MDG60B</b>	Single Shaft/Double Shaft	<b>DG60-ARA</b> <b>DG60-ARB</b>
<b>MDG85A</b>	Single Shaft	<b>DG85R-ARA</b>
<b>MDG85B</b>	Single Shaft/Double Shaft	<b>DG85R-ARA</b> <b>DG85R-ARB</b>
<b>MDG130A</b>	Single Shaft	<b>DG130R-ARA</b>
<b>MDG130B</b>	Single Shaft/Double Shaft Electromagnetic Brake Type	<b>DG130R-ARA</b> <b>DG130R-ARB</b> <b>DG130R-ARM</b>

● The product names of the applicable products are described with text by which the product name can be identified.



The following items are included in each product.  
Hexagon socket head screws for actuator assembly, positioning pins, bands (for cable clamping), band bases, set screws for band bases

# Controllers (Sold separately)

## Universal Controller

# SCX11 RoHS

## Feature

Equipped with program editing and execution functions, the highly-functional and sophisticated SCX11 controller is now available. Use the SCX11 as a stored program controller to connect to any of Oriental Motor's standard pulse input drivers. The SCX11 is also able to control the motor via various serial ports such as USB, RS-232C and **CANopen**

- 100 Sequence Programs can be Stored
- Easy Operation
- Intelligent Setting



## Product Line

Product Name	Driver Product Name
<b>SCX11</b>	ARD-C, ARD-A, ARD-S, ARD-K

Lineup

Features

How to Read  
Specifications Table

System  
Configuration

Product Line

Specifications and  
Characteristics

Dimensions

Connection  
and Operation

Combination  
List

Accessories

# Orientalmotor

These products are manufactured at plants certified with the international standards **ISO 9001** (for quality assurance) and **ISO 14001** (for systems of environmental management).

Specifications are subject to change without notice.  
Published in March 2015.

## ORIENTAL MOTOR (EUROPA) GmbH

[www.orientalmotor.de](http://www.orientalmotor.de)

### European Headquarters

Schiesstraße 74

40549 Düsseldorf, Germany

Tel: 0211-5206700 Fax: 0211-52067099



### Other countries:

[www.orientalmotor.eu](http://www.orientalmotor.eu)



## ORIENTAL MOTOR (UK) LTD.

[www.oriental-motor.co.uk](http://www.oriental-motor.co.uk)

### UK Headquarters

Unit 5, Faraday Office Park,

Rankine Road, Basingstoke,

Hampshire RG24 8AH, U.K.

Tel: 01256-347090 Fax: 01256-347099



## ORIENTAL MOTOR (FRANCE) SARL

[www.orientalmotor.fr](http://www.orientalmotor.fr)

### France Headquarters

56, Rue des Hautes Pâtures

92000 Nanterre Cedex, France

Tel: 01 47 86 97 50 Fax: 01 47 82 45 16



## ORIENTAL MOTOR ITALIA s.r.l.

[www.orientalmotor.it](http://www.orientalmotor.it)

### Italy Headquarters

Via A. De Gasperi, 85

20017 Mazzo di Rho (MI), Italy

Tel: 02-93906346 Fax: 02-93906348



## ORIENTAL MOTOR CO., LTD.

[www.orientalmotor.co.jp](http://www.orientalmotor.co.jp)

### Headquarters

4-8-1 Higashiueno

Taito-ku, Tokyo 110-8536, Japan

Tel: (03)6744-0361 Fax: (03)5826-2576

## Customer Center (Support in German & English)

00800-22 55 66 22\*  
CA LL OM CC

Mon-Thu: 08:00 - 17:30 CET Friday: 08:00 - 16:00 CET

\* Free Call Europe

[info@orientalmotor.de](mailto:info@orientalmotor.de)

For more information please contact: