

# 2-Phase Stepping Motors PK Series

● Connection Information ●  
 Technical reference → Page G-1  
 Safety standards → Page H-2

28 mm

42 mm

50 mm

56.4 mm

60 mm

85 mm

90 mm

In 2-Phase **PK** Series, in addition to a standard type with a resolution of 200 steps per revolution ( $1.8^\circ/\text{step}$ ), a high-resolution type (Resolution: 400 steps per revolution) and a geared type (high torque, higher resolution) are also available. The dedicated driver is required separately to operate the motor.

RoHS

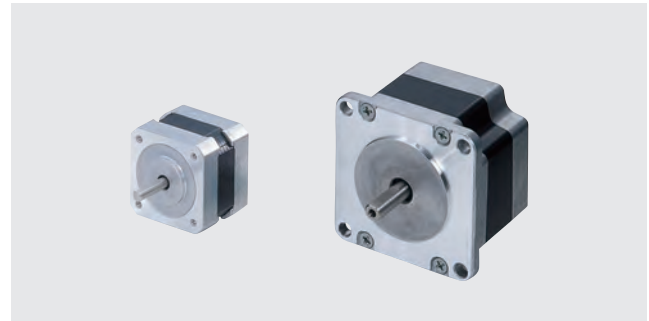

## Features

### ● Wide Variety

A high-resolution type, high-torque, high-efficiency type, high-torque type, standard type, standard type with terminal box and **SH** geared type are also available.

### ◇ High-Resolution Type

The basic step angle is  $0.9^\circ$ , which is half that of the standard type. 400 steps per rotation is possible. This motor achieves high resolution, improved stopping accuracy and low vibration.

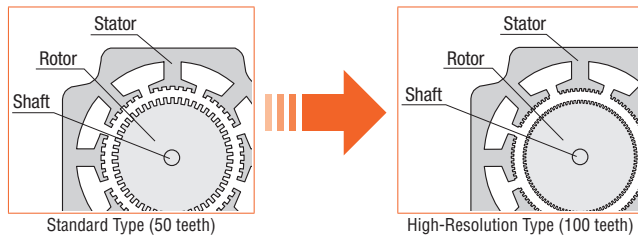

The small basic step angle allows the torque to increase sharply while minimizing the negative effect of frictional load.

### Comparison of Angle – Torque Characteristics

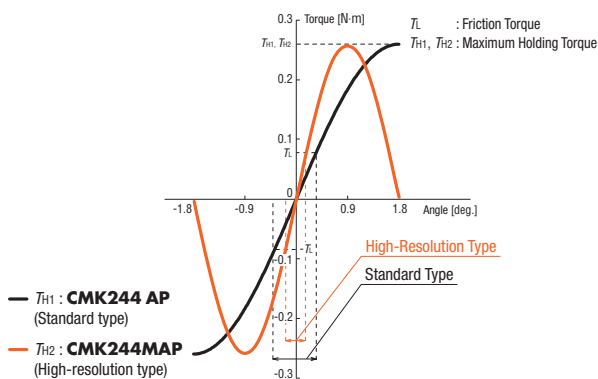

### ● Avoidance of Resonance Regions

If the used pulse speed is within a resonance region, vibration can increase. Resonance regions can be avoided by switching to a high-resolution type.

### ◇ High-Torque, High-Efficiency Type

#### ● Lower Heat Generation

Utilizing the latest in motor technology, the high-torque, high-efficiency type stepping motors are able to achieve a significant reduction in the amount of heat generated from the motor. (There is a 50% reduction in temperature rise compared with conventional models.)

#### Motor Case Temperature under the Same Operating Conditions

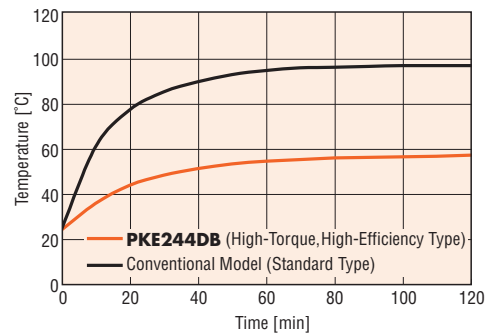

#### Temperature Distribution by Thermography



● Comparison under the Same Operating Conditions

### ● Lower Power Consumption

This model has achieved a 31% reduction\* in power consumption through energy savings and a reduction of 10 kg/per year in CO<sub>2</sub> emissions.

#### Power Consumption

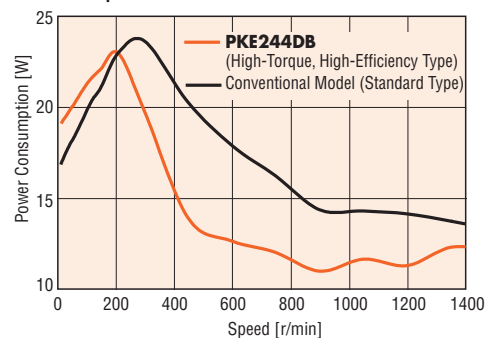

\*450 r/min, continuous operation

## ◇ High-Torque Type

The high-torque type provides, on average, 1.5 times higher torque than a standard stepping motor. By utilizing a larger rotor diameter, larger magnets can be used to significantly increase the output torque.

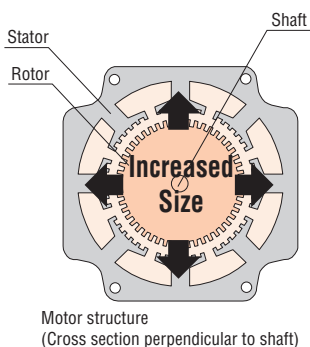

## ◇ Standard Type

The basic model offers an optimal balance of torque, low vibration and noise reduction.

## ◇ Standard Type with Cable

The motor conforms to the IP54 standard to changing the lead wire outlet form lead wire to cable and cable clamp (excluding the mounting surface.)

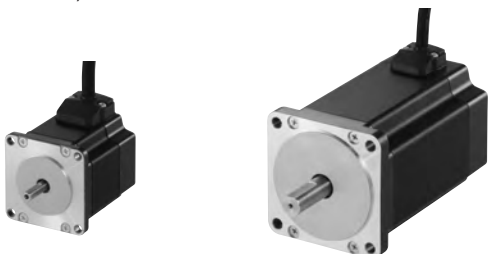

## ◇ Standard Type with Terminal Box

Terminal boxes have excellent watertightness and dust-resistance. This product conforms to the IP65 motor specification for the degree of protection (excluding shaft penetration).

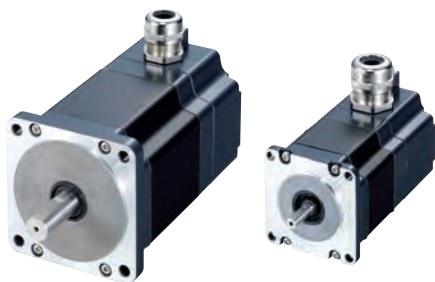

## ● Terminal-Block Connection Design

The motor can be wired directly from its terminal block.

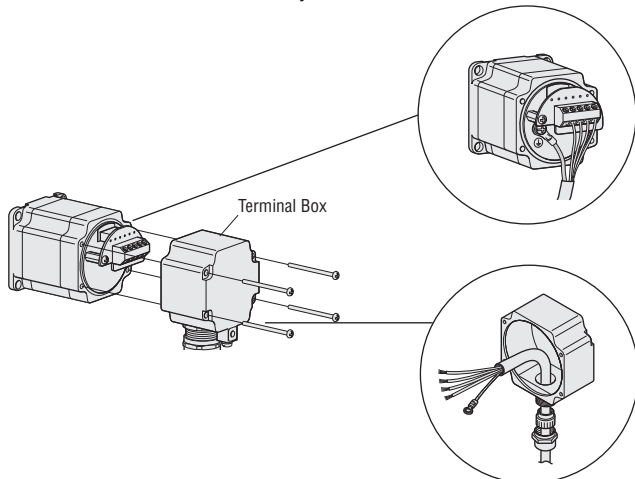

## ● No Motor/Driver Relay

Since the motor cable can be connected directly to the driver terminals, there is no need for wire connection or soldering on a relay terminal block.

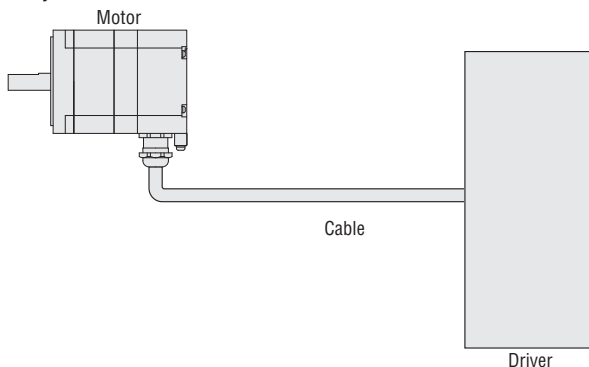

## ◇ SH Geared Type

This geared type is effective for reducing speed, increasing torque, higher resolution and low vibration. Eight types of gear ratios are available.

Introduction	
AC Input Motor & Driver	
0.36°/Geared AR Q <sub>572P</sub>	0.72°/Geared RK Q <sub>572P</sub>
0.36°/Geared AR Q <sub>572P</sub>	
DC Input Motor & Driver	
0.36°/0.72°/Geared CRK Q <sub>572P</sub>	1.8°/Geared RBK Q <sub>572P</sub>
0.9°/1.8°/Geared CMK Q <sub>572P</sub>	
Motor Only	
0.72° PK Q <sub>572P</sub>	1.8°/Geared High-Torque PK Q <sub>572P</sub>
0.9°/1.8°/Geared PK Q <sub>572P</sub>	
Controllers	
SG80301Y	
Accessories	

## Motor Lineup

Type	Features	Frame Size			
		28 mm	42 mm	50 mm	56.4 mm
High-Resolution Type	These have half the basic step angle of the standard type, increasing resolution and stopping accuracy.		 Page A-286, A-287		 Page A-291, A-293
High-Torque, High-Efficiency Type	It achieves lower heat generation and lower power consumption with high-efficiency technology. It uses a high-torque designed motor.		 Page A-297, A-298		
High-Torque Type	A high-torque motor generates higher torque of more than 1.5 times compared with the conventional standard type motor.				
Standard Type	These are standard type motors with a wide variety of current specifications.		 Page A-303, A-304	 Page A-308	 Page A-309, A-311
<b>SH</b> Geared Type	These are effective for deceleration, increased torque, increased resolution, and vibration suppression. They have a wide variety of gear ratios.		 Page A-323		
<b>TH</b> Geared Type	A geared motor achieving both low backlash and low cost.		 Page A-327, A-328		
<b>PL</b> Geared Type <b>PS</b> Geared Type	A geared stepping motor with planetary gear mechanism offering low backlash, high strength.	 Page A-331	 Page A-332		

60 mm	85 (90) mm	With Encoder	With Cable	With Terminal Box	Connection Type	
					Bipolar	Unipolar
		 Page A-288, A-294	-	-	●	●
		-	-	-	●	●
 Page A-300, A-301		-	-	-	●	●
	 Page A-315, A-316	 Page A-305, A-312	 Page A-318, A-319	 Page A-320, A-321	● (Except for frame size 50 mm)	●
 Page A-324	 Page A-325	-	-	-	-	●
 Page A-329, A-330		-	-	-	●	●
 Page A-333		-	-	-	●	-

Introduction

0.36°/Geared  
AR  
AC Input Motor & Driver

0.72°/Geared  
RK  
AC Input Motor & Driver

0.36°/Geared  
AR  
DC Input Motor & Driver

0.36°/0.72°/  
Geared  
CRK  
DC Input Motor & Driver

0.9°/1.8°/Geared  
CMK  
DC Input Motor & Driver

0.72°  
PK  
Motor Only

1.8°/Geared  
High-Torque  
PK  
Motor Only

0.9°/1.8°/Geared  
PK  
Motor Only

Controllers  
SG8030JY

Accessories