

Stepping Motors

Stepping Motor and Driver Packages

## AC Power Supply Input

*α*STEP AR Series

RK Series

Introduction

0.36°/Geared  
AC Input Motor & Driver  
AR  
0.72°/Geared  
RK

0.36°/Geared  
AR

0.36°/0.72°/  
Geared  
DC Input Motor & Driver  
CRK  
1.8°/Geared  
RBK

0.9°/1.8°/Geared  
CMK

0.72°  
PK

1.8°/Geared  
High-Torque  
Motor Only  
PKP

0.9°/1.8°/Geared  
PK

Controllers  
SG8030JY

Accessories

Page

AR Series .....	A-24
RK Series .....	A-68

# Overview of Stepping Motor and Driver Packages $\alpha$ STEP

The  $\alpha$ STEP utilizes our unique closed loop control.

This is a motor and driver package product offering the user-friendliness of a stepping motor combined with improved response and reliability.

## Features

- Uses Oriental Motor's Original Closed Loop Control Technology

- ◇ Maintains Operation Even During Abrupt Load Fluctuations and Accelerations.

The **AR** Series uses our closed loop control to maintain positioning operation even during abrupt load fluctuations and accelerations. The rotor position detection sensor monitors the rotation.

When an overload condition is detected, the **AR** Series will instantaneously regain control using the closed loop mode.

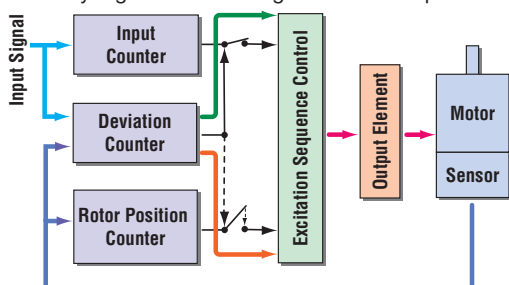

**Normal (Positioning deviation is less than  $\pm 1.8^\circ$ )**

Motor runs in open loop mode like a stepping motor.

**During Overload Condition (Positioning deviation is  $\pm 1.8^\circ$  or more)**

The closed loop mode is engaged to maintain the positioning operation.

- ◇ Rotor Position Detection Sensor

The rotor position detection sensor uses the change in inductance caused by change in the distance between the stator teeth and the teeth on the sensor rotor to detect rotor position.

- This structure can be made small and thin, so the overall size of the motor can be reduced.
- High resolution
- This structure does not use electronic parts, so it is not affected by heat or vibration.

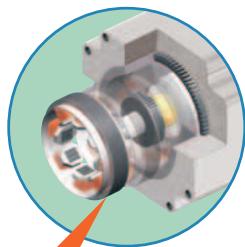

Sensor detects rotor position

- Alarm Signal Output in Case of Abnormality

If an overload is applied continuously, an alarm signal is output. When the positioning is complete, an END signal is output. This ensures the same level of reliability achieved by a servo motor.

- Maintaining All the Beneficial Features of a Stepping Motor

- ◇ User-Friendly and Easy, Highly Accurate Positioning

Stepping motors provide convenient means to ensure highly accurate positioning because they synchronize themselves with commands without requiring feedback.

- ◇ High Response

The motor operates synchronously with pulse commands to achieve high response. There's no delay in operation following a pulse command.

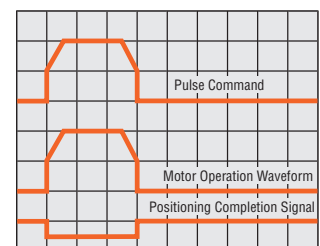

- ◇ No Tuning

With the **AR** Series, you can perform positioning quickly after a load change, etc., without adjusting any gains.

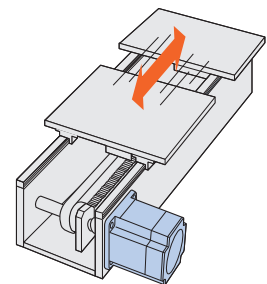

- ◇ No Hunting

Because it uses a stepping motor, the **AR** Series does not hunt when stopped. Accordingly, the **AR** Series is ideal for applications where the equipment uses a belt-drive mechanism or otherwise has low rigidity and you don't want it to vibrate when stopping.

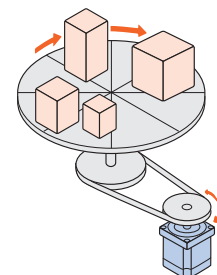

## Selectable Drivers by System

### Pulse Input

#### Pulse Control

The motor can be controlled using a pulse generator provided by the customer. Operating data registered in the pulse generator is selected from the programmable controller to operate the motor.

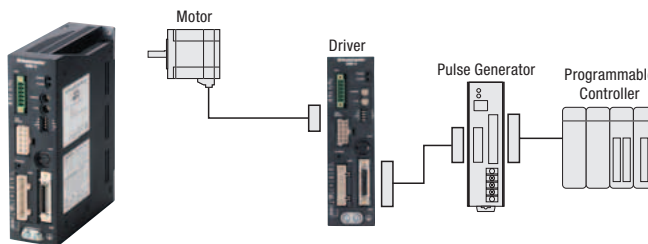

### Built-In Controller

#### I/O Control

The function of a built-in pulse generator lets you build an operation system by connecting directly to a programmable controller. No separate pulse generator is required, which contributes to space saving.

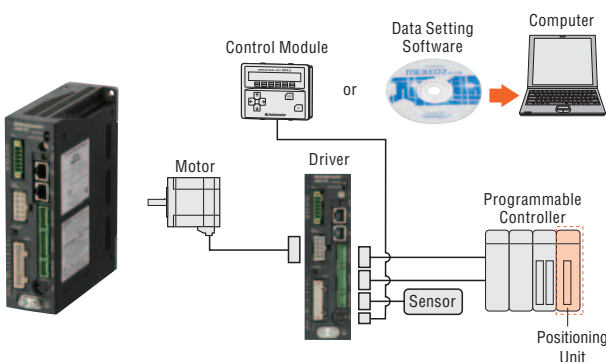

#### Modbus (RTU) Control

Operating data, parameter settings or operation commands can be input via RS-485 communication. A maximum of 31 drivers can be connected to one serial unit. There is also a function for simultaneously starting multiple axes.

The protocol is compatible with Modbus (RTU) and can be easily connected via PLC, etc.

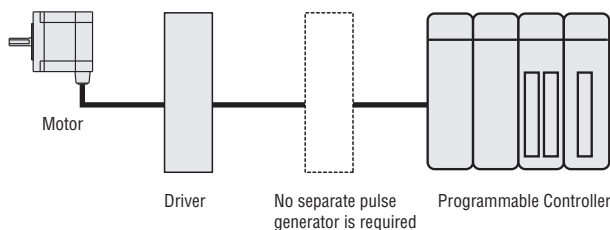

Introduction

0.36°/Geared  
C-Series  
AR  
AC Input Motor & Driver

0.36°/Geared  
C-Series  
AR

0.36°/0.72°/  
Geared  
C-Series  
CRK  
DC Input Motor & Driver

1.8°/Geared  
RRK

0.9°/1.8°/Geared  
CMK

0.72°  
PK  
Motor Only

1.8°/Geared  
High-Torque  
PKP

0.9°/1.8°/Geared  
PK

Controllers  
SG8030JY

Accessories

## ■ Built-In Controller Package

The burden on the programmable PLC is reduced because the information necessary for motor operations is built into the driver. This simplifies the system configuration for multi-axis control.

Set with control module (sold separately), data setting software, or RS-485 communication.

**Basic Settings**  
(Factory settings)

Motor



Driver



Connection Cable



+

**Operation Data Settings**  
**Parameter Changes**



Control Module  
**(OPX-2A)**

or

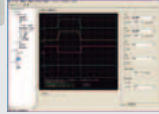

Data Setting Software **(MEXEO2)**

● Setting via RS-485 communication is also possible.

- Data Setting
- Test Operation
- Alarm History
- Parameter Changes
- Monitor
- Data Copy

## ● Operation type

With built-in controller packages, the motor's operating speed and traveling amount are set with operating data and operations performed based on the selected operating data. The operation type is 4-pattern.

Item		Content		
Common	Control Method	I/O Control RS-485 communication      Modbus RTU Protocol Connection		
	Position Command Input	Set with operating data number    Command range per point: -8388608~8388607 [steps] (setting unit: 1 [step])		
	Speed Command Input	Set with operating data number    Command range: 0~1000000 [Hz] (setting unit: 1 [Hz])		
	Acceleration/Deceleration Command Input	Set with operating data number or parameters. Acceleration/deceleration rate [ms/kHz] or acceleration/deceleration time [s] can be selected. Command range: 0.001~1000.000 [ms/kHz] (setting unit: 0.001 [ms/kHz]) 0.001~1000.000 [s] (setting unit: 0.001 [s])		
	Acceleration/Deceleration Control	Velocity filter, moving average filter		
Return-To-Home Operation	Return-To-Home Method	2-sensor mode	This is the return-to-home operation using limit sensors (+LS, -LS).	
		3-sensor mode	This is the return-to-home operation using limit sensors and HOME sensor.	
		Pushing mode*	This is the return-to-home operation for pushing to the mechanical end of a linear slide, etc.	
		Position preset	This function allows a home position to be confirmed by inputting P-PRESET using an arbitrary position. An arbitrary value can be set for the home position.	
Positioning Operation	Number of Positioning Points	64 points (No. 0~63)		
	Operation Mode	Incremental mode (Relative positioning)		
		Absolute mode (Absolute positioning)		
	Operation Functions	One-shot operation	This is a PTP (Point to Point) positioning operation.	
		Linked operation	This is a multistep speed-change positioning operation linked to operating data.	
		Linked operation 2	This is a positioning operation with timer linked to operating data. The timer (dwell time) can be set in the range of 0~50.000 [s]. (Setting unit: 0.001 [s])	
		Push-motion operation*	Continuous pressurizing position operations are performed with respect to load. The operating speed is maximum 30 [r/min] with the motor shaft.	
	Starting Methods	Operating data selection mode	The positioning operation starts when START is input after M0~M5 has been selected.	
		Direct mode (direct positioning)	The positioning operation starts with the operating data number that was set with the parameters when MS0~MS5 has been input.	
Sequential mode (sequential positioning)		The positioning operation starts in order from operating data No. 0 every time SSTART is input.		
Continuous Operation	Number of Speed Points	64 points (No. 0~63)		
	Speed-Change Method	This switches the operating data number.		
Other Operations	JOG Operation	+JOG or -JOG is input, and regular feeding is performed.		
	Automatic Return Operation	This automatically returns to the original stopped position when the motor has become misaligned due to an external force during non-excitation.		

\*Do not perform push-motion operations with geared types. Doing so will damage the motor and gearhead.

## Positioning Operation

Operation Function

### ● One-Shot Operation

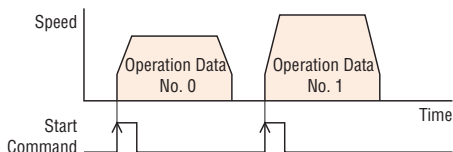

### ● Linked Operation

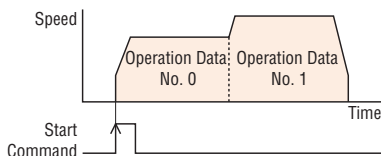

### ● Linked Operation 2

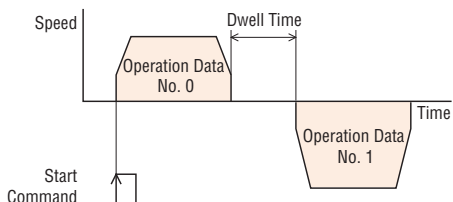

### ● Push-Motion Operation

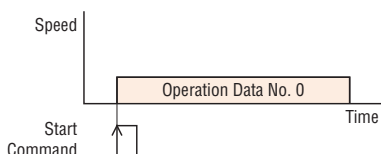

Start Method

- Data-Select Positioning
- Direct Positioning
- Sequential Positioning

## Return-To-Home Operation

### ● 2-Sensor Mode

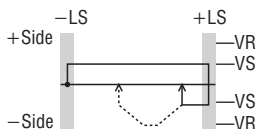

### ● 3-Sensor Mode

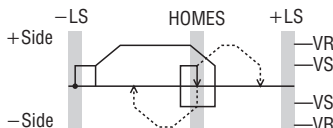

### ● Push-Motion Mode

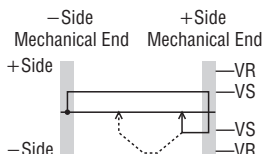

### ● Position Preset

## Continuous Operation

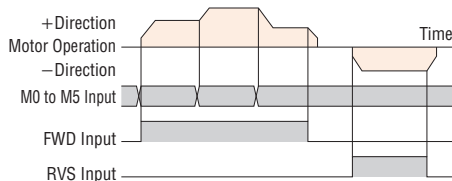

## Other Operations

### ● JOG Operation (Test Operation)

### ● Automatic Return

- This comes with the return-to-home operation sequence installed, so the burden on the programmable master is reduced and there is no need to create a ladder.

## Group Sending Function (Via RS-485 communication)

Groups can be configured with multiple axes connected via RS-485 communication, and commands sent for each group. Multi-axis simultaneous starting and identical operations are also possible.

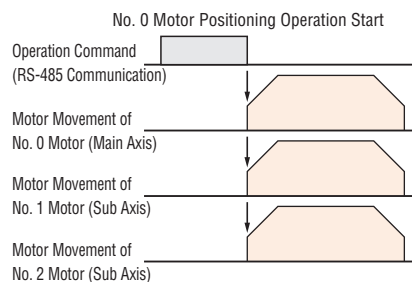

## Teaching Function

Teaching can be done using the control module **OPX-2A** (sold separately) or data setting software **MEXE02**. The table is moved to the desired position, and the position data at that time stored as the positioning data.

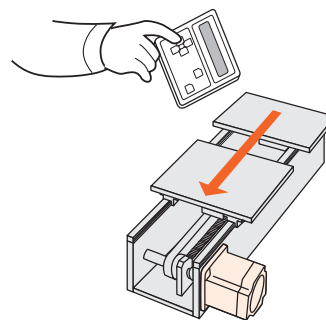

- Introduction
- 0.36°/Geared  
C-Series  
AR AC Input Motor & Driver
- 0.72°/Geared  
RK
- 0.36°/Geared  
C-Series  
AR
- 0.36°/0.72°/  
Geared  
CRK DC Input Motor & Driver
- 1.8°/Geared  
RRK
- 0.9°/1.8°/Geared  
CMK
- 0.72°  
PK
- 1.8°/Geared  
High-Torque  
PKP Motor Only
- 0.9°/1.8°/Geared  
PK
- Controllers  
SG80301Y
- Accessories

## ■ Pulse Input Package

By using the data setting software and control module, sold separately, parameters can be changed, the alarm history displayed, and each monitor handled according to your demands.

**Basic Settings**  
(Factory settings)



+

**Extended Settings**



Control Module  
**(OPX-2A)**

or

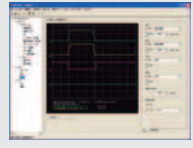

Data Setting Software **(MEXE02)**

- Push-Motion Operation
- Test Operation
- Alarm History
- Parameter Changes
- Monitor
- Data Copy

## ● Main Additional Functions from Extended Settings

Item	Overview	Basic Settings	Extended Settings
Pulse Input Mode Selection	1-pulse input mode or 2-pulse input mode (negative logic) can be selected.	●	●
	Beyond the normal settings, the phase difference input can also be set. <ul style="list-style-type: none"> <li>• 1-pulse mode (positive logic/negative logic)</li> <li>• 2-pulse mode (positive logic/negative logic)</li> <li>• Phase difference input (1×/2×/4×)</li> </ul>	—	●
Resolution Setting	The resolution can be selected with a function switch (D0, D1, CS0, CS1).	●	●
	The value of the electronic gears corresponding to each function switch (D0, D1, CS0, CS1) can be changed.	—	●
Running Current Setting	The running current setting can be changed with the current setting switch (CURRENT).	●	●
	The value corresponding to each stage of the current setting switch (CURRENT), 0~F (16 stages), can be changed.	—	●
Standstill Current Ratio Setting	The ratio of the standstill current with respect to the running current can be set.	—	●
Motor Rotation Coordinate Setting	The motor's rotation coordinate can be set.	—	●
All Windings On Signal (C-ON input)	This is the input signal for exciting the motor.	●	●
	The logic of the C-ON input during power supply input can be set.	—	●
Excitation Position Return-To-Home Operation when All Windings are On Enabled/Disabled	Whether or not an operation to return to the excitation position (deviation 0 position) is performed when all windings are on can be set.	—	●
I/O Input Signal Mode Selection	Input when a push-motion operation is performed.	—	●
Alarm Code Signal Enabled/Disabled	Set when code output is desired when an alarm has occurred.	—	●
END Signal Output Width Setting	The END signal output width can be changed.	—	●
END Signal Output Offset	The END signal output value can be offset.	—	●
A/B Phase Output	This can be used to confirm the position of the motor.	●	●
Timing Signal Output	This is output every time the motor rotates 7.2°.	●	●
Velocity Filter Setting	This places a filter on the operation command and suppresses motor behavior.	●	●
	The value corresponding to each stage of the setting switch, 0~F (16 stages), can be changed.	—	●
Vibration Suppression Function for Normal Mode	This can be set to suppress resonance vibration during rotation.	—	●
	This can be set to suppress vibration during acceleration and deceleration, and when stopped.	—	●
Gain Adjustment for Current Control Mode*	This adjusts the position/speed loop gain.	—	●
	This adjusts the constant during velocity integration.	—	●
	This sets the damping control vibration frequency.	—	●
	This sets the damping control as enabled/disabled.	—	●
Motor Excitation Position Selection When Power is On	The motor excitation position when the power is on can be selected.	—	●
Control Module Settings	Whether the speed display of the control module is signed or an absolute value can be selected.	—	●
	The geared motor gear ratio for the speed monitor can be set.	—	●

\*Oriental Motor recommends using normal mode unless you want to further reduce heat generation and noise.

## ◇ Return Operation

Two return operation functions are available: Return to electrical home operation and automatic return operation. With these options, you can easily set up your system to return home when the main power has been cut off due to an emergency stop, etc., or the motor excitation has been turned off.

- While the main power is cut off, the control power (24 VDC) must be supplied.

### ● Return to Electrical Home Operation

An operation in which the motor returns to the “position it had assumed when the power was turned on (= electrical home)” or “location set as the electrical home.”

### ● Automatic Return Operation

An operation in which the motor returns to the “position at which motor excitation was turned off (= the C-ON input turned OFF or FREE input turned ON).”

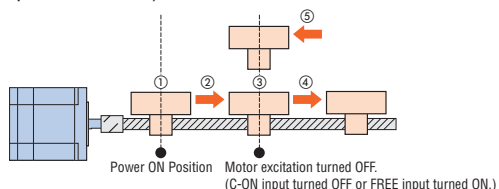

## ◇ Push-Motion Operation

The load is pressurized continuously. When contact is made with the load, pushing operation begins, and the pressurization can be carried out at a steady torque.

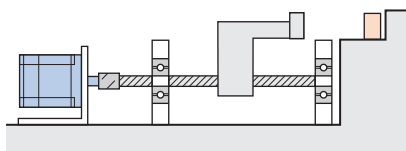

## ◇ Position Management in the Same Direction is Possible

Position management is possible using the round function, even in applications that require repeated positioning in the same direction. (Only in built-in controller packages.)

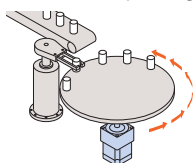

Introduction

0.36°/Geared  
AR  
AC Input Motor & Driver

0.72°/Geared  
RK

0.36°/Geared  
AR  
DC Input Motor & Driver

0.36°/0.72°/  
Geared  
CRK

1.8°/Geared  
RBK  
DC Input Motor & Driver

0.9°/1.8°/Geared  
CMK

0.72°  
PK

1.8°/Geared  
High-Torque  
PKP  
Motor Only

0.9°/1.8°/Geared  
PK

Controllers  
SG80301Y

Accessories

# 0.36° Closed Loop Stepping Motor and Driver Package $\alpha$ STEP High-Efficiency AR Series

● Connection Information  
 Technical reference → Page G-1  
 Safety standards → Page H-2

This series substantially reduces heat generation from the motor through the use of high-efficiency technology. It allows you to take advantage of the beneficial features of the stepping motor to perform quick positioning operations over a short distance repeatedly without worrying about the duty cycle.



● For detailed product safety standard information including standards, file number and certification body, please visit [www.orientalmotor.eu](http://www.orientalmotor.eu).  
 \*Pulse Input Package only



## Features

- **Incorporating Our Unique Closed Loop Control**  
 For details, refer to “Overview of Stepping Motor and Driver Package  $\alpha$ STEP” on page A-18.
- **Continuous Operation is Achieved Due to the Reduction of Motor Heat Generation by Utilizing High-Efficiency Technology**

### ◇ Lower Heat Generation

The **AR** Series utilizes high-efficiency technology to achieve a significant reduction in the amount of heat generated from the motor.

● Temperature Distribution by Thermography

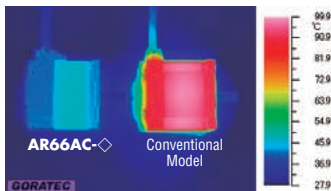

Comparison under the same conditions

● Motor Case Temperature under Same Operating Conditions

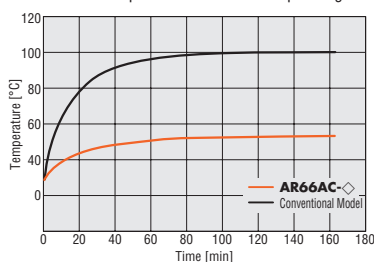

### ◇ Energy-Saving

Power consumption: up to **66%** less than a conventional model

● Power Consumption

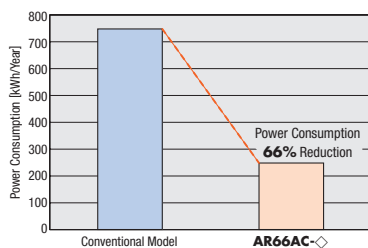

CO<sub>2</sub> emission: up to **66%** less\* than a conventional model

\* Operating Condition

Speed: 1000 r/min, Load Factor: 50%

Operating Time: 24 hours of operation (70% operating, 25% standing by, 5% standstill), 365 days/year

- ◇ **Continuous Operation or Operation at a High Duty Cycle**  
 The **AR** Series can be operated at high frequency. You can drive the motor continuously.

### Note

● If the motor is operated continuously, a heat sink of a capacity at least equivalent to an aluminum plate with a size of 250×250 mm, 6 mm thick is required.

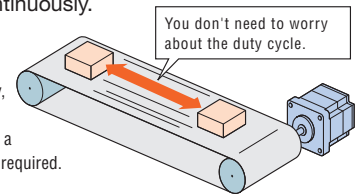

- **A Stepping Motor with Advanced Characteristics That's Easier to Use**

### ◇ Compact and High Torque

Stepping motors generate high torque with a compact body. Since a stepping motor has a shorter overall length compared to a servo motor of the same frame size (also by Oriental Motor), the device space can be reduced.

● Comparison with Servo Motors of the Same Frame Size

**AR46** (Standard Type) and Servo Motor (50 W/100 W)

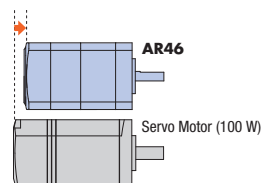
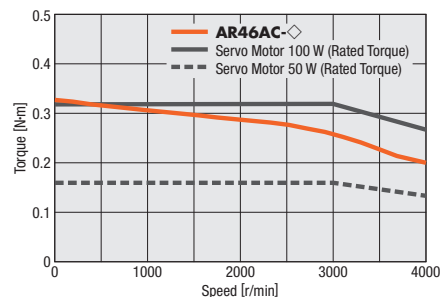



**AR66** (Standard Type) and Servo Motor (100 W/200 W)

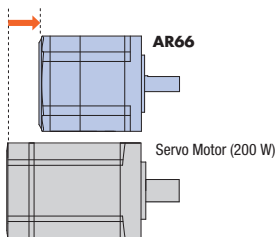
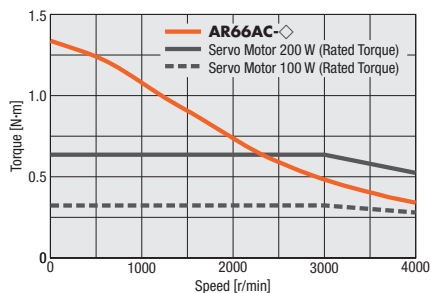

**AR69** (Standard Type) and Servo Motor (200 W/400 W)

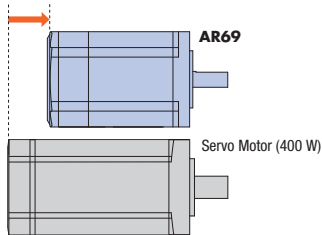
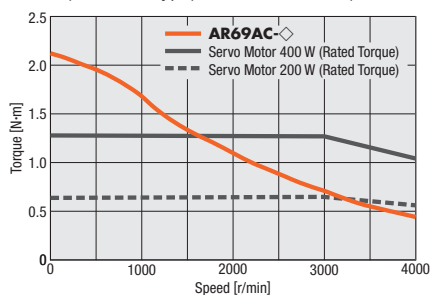

**AR911** (Standard Type) and Servo Motor (400 W/750 W)

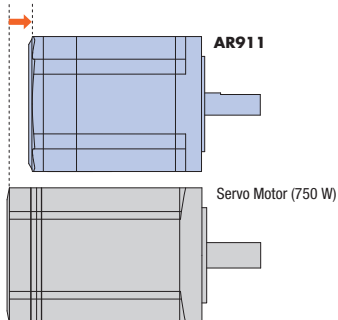
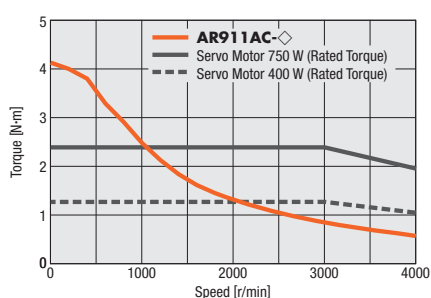

## Capable of Driving Large Inertial Loads

Compared with a servo motor of the same frame size, a larger inertial load can be driven regardless of speed conditions.

### Comparison at 30 times of the rotor inertia

#### AR Series

Load Inertia  $22.4 \times 10^{-4} \text{ kg-m}^2$   
(30 times the rotor inertia)

Load Inertia: Diameter: 169 mm,  
Thickness: 10 mm,  
Material: Aluminum  
Motor: Frame Size 60 mm  
Length 90 mm

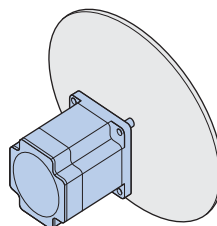

#### Conventional Servo Motor

Load Inertia  $4.0 \times 10^{-4} \text{ kg-m}^2$   
(30 times the rotor inertia)

Load Inertia: Diameter: 110 mm,  
Thickness: 10 mm,  
Material: Aluminum  
Motor: Frame Size 60 mm  
Length 96.5 mm

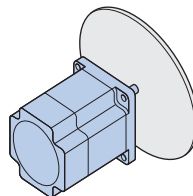





### Selectable Drivers by System

For details, refer to "Overview of Stepping Motor and Driver Packages  $\alpha$ STEP" on page A-18.

Introduction
AC Input Motor & Driver
0.36°/Geared AR
0.72°/Geared RK
DC Input Motor & Driver
0.36°/Geared AR
0.36°/0.72°/Geared CRK
1.8°/Geared RBK
0.9°/1.8°/Geared CMK
Motor Only
0.72° PK
1.8°/Geared High-Torque PKP
0.9°/1.8°/Geared PK
Controllers SG80301Y
Accessories

## Motor Lineup



### Characteristics Comparison for Motors and Geared Motors

Motor Type Geared Type	Features	Permissible Torque Maximum Torque [N·m]	Backlash [arc min (degrees)]	Basic Resolution [deg/step]	Output Shaft Speed [r/min]
<b>Standard</b> 	<ul style="list-style-type: none"> <li>Basic model of the AR Series</li> </ul>	Maximum Holding Torque 4	—	0.36	4000
<b>Low backlash</b>	<b>TH Geared</b> (Parallel shaft) 	12	45 (0.75)	0.012	500
	<b>PS Geared</b> (Planetary) 	Permissible Torque 37 Maximum Torque 60	25 (0.42)	0.0072	600
	<b>PN Geared</b> (Planetary) 	<ul style="list-style-type: none"> <li>High Speed (Low gear ratio), High Positioning Accuracy</li> <li>High Permissible Torque/Maximum Torque</li> <li>A wide variety of gear ratios for selecting the desired step angle</li> <li>Center Shaft</li> <li>Gear Ratio Types 5, 7.2, 10, 25, 36, 50</li> </ul>	Permissible Torque 37 Maximum Torque 60	3 (0.05)	0.0072
<b>Non-backlash</b>	<b>Harmonic Geared</b> (Harmonic drive) 	Permissible Torque 37 Maximum Torque 55	0	0.0036	70

#### Note

● The values shown above must be used as reference. These values vary depending on the frame size and gear ratio.

### Power Supply Voltage and Range of Motor Frame Size

	Power Supply Voltage	Motor Type	
		Standard Type	TH Geared Type PS Geared Type PN Geared Type Harmonic Geared Type
<b>Built-In Controller Package</b> 	Single-Phase 200-240 VAC	<input type="checkbox"/> 42 <input type="checkbox"/> 60 <input type="checkbox"/> 85	<input type="checkbox"/> 42 <input type="checkbox"/> 60 <input type="checkbox"/> 90
<b>Pulse Input Package</b> 	Single-Phase 200-230 VAC	<input type="checkbox"/> 42 <input type="checkbox"/> 60 <input type="checkbox"/> 85	<input type="checkbox"/> 42 <input type="checkbox"/> 60 <input type="checkbox"/> 90

● 42: indicates a motor frame size of 42 mm.

● Electromagnetic brake models are available for all types.

## System Configuration

### Built-In Controller Package Standard Type with Electromagnetic Brake

An example of a system configuration when used with either I/O control or RS-485 communication.

\*1 Not supplied

\*2 To be provided as necessary

**Accessories (Sold separately)**

① Connection Cable Set  
Flexible Connection Cable Set  
(→ Page A-343)

② Extension Cable Set  
Flexible Extension Cable Set  
(→ Page A-344)

**Accessories (Sold separately)\*2**

③ Control Module  
(→ Page A-378)

④ Data Setting Software  
(→ Page A-379)

24 VDC Power Supply for Control\*1

Computer\*1

To USB Port

**AR Series**

**Motor**

For Electromagnetic Brake

For Motor

**Driver**

For RS-485 Communication

Programmable Controller\*1

Sensor\*1

AC Power Supply\*1  
(Main power supply)

The product comes with a 1 m, 2 m or 3 m cable  
(for motor and electromagnetic brake).

**Accessories (Sold separately)**

⑤ Motor Mounting Brackets  
(→ Page A-369)

⑥ MCS Couplings  
(→ Page A-359)

⑦ Cable for RS-485 Communication  
(→ Page A-345)

Number	Name	Overview
①	Connection Cable Sets Flexible Connection Cable Sets	These cable sets are used to connect the motor and driver without using the included cables.
②	Extension Cable Sets Flexible Extension Cable Sets	These cable sets are used to extend the wiring distance between the motor and driver using the included cables.
③	Control Module	This control module lets you set (edit, monitor, operate) various data and enables extended functions. Comes with a communication cable (5 m).
④	Data Setting Software	This data setting software lets you set (edit, monitor, operate) various data and enables extended functions. Comes with a PC interface cable (5 m) and a USB cable (0.5 m).
⑤	Motor Mounting Brackets	Dedicated mounting bracket for the motor.
⑥	MCS Couplings	Coupling that connects the motor shaft to the driven shaft.
⑦	Cable for RS-485 Communication	These cables are used to link drivers when a built-in controller type is being operated in a multi-drop manner.

### System Configuration Example



●The system configuration shown above is an example. Other combinations are available.

## System Configuration

### Pulse Input Package Standard Type with Electromagnetic Brake

An example of a single-axis system configuration with the **SG8030JY** controller.

\* Not supplied

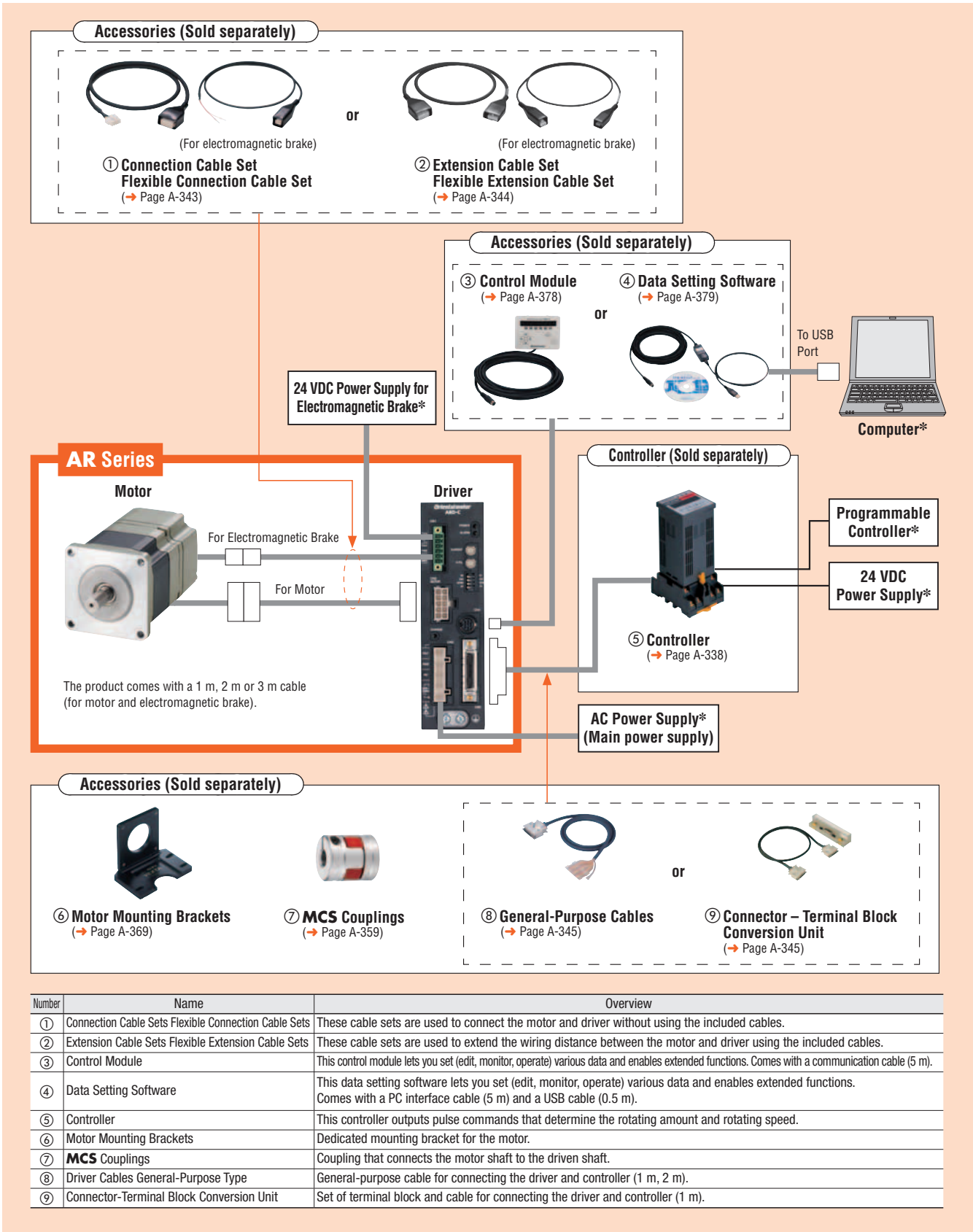

### System Configuration Example

AR Series	Sold Separately			
	Controller	Motor Mounting Bracket	Flexible Coupling	Connector – Terminal Block Conversion Unit (1 m)
<b>AR66MC-3</b>	<b>SG8030JY-U</b>	<b>PAL2P-5</b>	<b>MCS201010</b>	<b>CC36T1</b>

The system configuration shown above is an example. Other combinations are available.

## Product Number Code

# AR 6 6 A C D - PS 10 - 1

① ② ③ ④ ⑤ ⑥ ⑦ ⑧ ⑨

①	Series Name	<b>AR: AR Series</b>
②	Motor Frame Size	<b>4:</b> 42 mm <b>6:</b> 60 mm <b>9:</b> 85 mm (90 mm)
③	Motor Case Length	
④	Motor Type	<b>A:</b> Standard (Single shaft) <b>B:</b> Standard (Double shaft) <b>M:</b> Electromagnetic Brake Type
⑤	Power Supply Voltage	Built-In Controller Package <b>A:</b> Single-Phase 100-120 VAC <b>C:</b> Single-Phase 200-240 VAC Pulse Input Package <b>A:</b> Single-Phase 100-115 VAC <b>C:</b> Single-Phase 200-230 VAC <b>S:</b> Three-Phase 200-230 VAC

⑥	Driver Type	<b>D:</b> Built-In Controller Package Blank: Pulse Input Package
⑦	Gearhead Type	Blank: Standard Type <b>T: TH</b> Geared Type <b>PS: PS</b> Geared Type <b>N: PN</b> Geared Type <b>H:</b> Harmonic Geared Type
⑧	Gear Ratio	
⑨	Cable Length (Included)	<b>1:</b> 1 m <b>2:</b> 2 m <b>3:</b> 3 m

## Product Line

● For the single-phase 100-120 VAC (single-phase 100-115 VAC for Pulse Input Package) models and three-phase 200-230 VAC models, please contact the nearest Oriental Motor sales office.

### Built-In Controller Package

#### ◇ Standard Type

Product Name (Single shaft)	Product Name (Double shaft)
<b>AR46A</b> □ <b>D</b> -◇	<b>AR46B</b> □ <b>D</b> -◇
<b>AR66A</b> □ <b>D</b> -◇	<b>AR66B</b> □ <b>D</b> -◇
<b>AR69A</b> □ <b>D</b> -◇	<b>AR69B</b> □ <b>D</b> -◇
<b>AR98A</b> □ <b>D</b> -◇	<b>AR98B</b> □ <b>D</b> -◇
<b>AR911A</b> □ <b>D</b> -◇	<b>AR911B</b> □ <b>D</b> -◇

#### ◇ Standard Type with Electromagnetic Brake

Product Name
<b>AR46M</b> □ <b>D</b> -◇
<b>AR66M</b> □ <b>D</b> -◇
<b>AR69M</b> □ <b>D</b> -◇
<b>AR98M</b> □ <b>D</b> -◇

#### ◇ TH Geared Type

Product Name	Product Name
<b>AR46A</b> □ <b>D-T3.6</b> -◇	<b>AR46M</b> □ <b>D-T3.6</b> -◇
<b>AR46A</b> □ <b>D-T7.2</b> -◇	<b>AR46M</b> □ <b>D-T7.2</b> -◇
<b>AR46A</b> □ <b>D-T10</b> -◇	<b>AR46M</b> □ <b>D-T10</b> -◇
<b>AR46A</b> □ <b>D-T20</b> -◇	<b>AR46M</b> □ <b>D-T20</b> -◇
<b>AR46A</b> □ <b>D-T30</b> -◇	<b>AR46M</b> □ <b>D-T30</b> -◇
<b>AR66A</b> □ <b>D-T3.6</b> -◇	<b>AR66M</b> □ <b>D-T3.6</b> -◇
<b>AR66A</b> □ <b>D-T7.2</b> -◇	<b>AR66M</b> □ <b>D-T7.2</b> -◇
<b>AR66A</b> □ <b>D-T10</b> -◇	<b>AR66M</b> □ <b>D-T10</b> -◇
<b>AR66A</b> □ <b>D-T20</b> -◇	<b>AR66M</b> □ <b>D-T20</b> -◇
<b>AR66A</b> □ <b>D-T30</b> -◇	<b>AR66M</b> □ <b>D-T30</b> -◇
<b>AR98A</b> □ <b>D-T3.6</b> -◇	<b>AR98M</b> □ <b>D-T3.6</b> -◇
<b>AR98A</b> □ <b>D-T7.2</b> -◇	<b>AR98M</b> □ <b>D-T7.2</b> -◇
<b>AR98A</b> □ <b>D-T10</b> -◇	<b>AR98M</b> □ <b>D-T10</b> -◇
<b>AR98A</b> □ <b>D-T20</b> -◇	<b>AR98M</b> □ <b>D-T20</b> -◇
<b>AR98A</b> □ <b>D-T30</b> -◇	<b>AR98M</b> □ <b>D-T30</b> -◇

#### ◇ Harmonic Geared Type

Product Name	Product Name
<b>AR46A</b> □ <b>D-H50</b> -◇	<b>AR46M</b> □ <b>D-H50</b> -◇
<b>AR46A</b> □ <b>D-H100</b> -◇	<b>AR46M</b> □ <b>D-H100</b> -◇
<b>AR66A</b> □ <b>D-H50</b> -◇	<b>AR66M</b> □ <b>D-H50</b> -◇
<b>AR66A</b> □ <b>D-H100</b> -◇	<b>AR66M</b> □ <b>D-H100</b> -◇
<b>AR98A</b> □ <b>D-H50</b> -◇	<b>AR98M</b> □ <b>D-H50</b> -◇
<b>AR98A</b> □ <b>D-H100</b> -◇	<b>AR98M</b> □ <b>D-H100</b> -◇

● Either **A** (single-phase 100-120 VAC) or **C** (single-phase 200-240 VAC) indicating the power supply input is entered where the box □ is located within the product name. A number indicating the desired length of **1** (1 m), **2** (2 m) or **3** (3 m) for the cable included with the product is entered where the box ◇ is located within the product name. Select a desired cable length from 1 m, 2 m and 3 m.

#### ◇ PS Geared Type

Product Name	Product Name
<b>AR46A</b> □ <b>D-PS5</b> -◇	<b>AR46M</b> □ <b>D-PS5</b> -◇
<b>AR46A</b> □ <b>D-PS7</b> -◇	<b>AR46M</b> □ <b>D-PS7</b> -◇
<b>AR46A</b> □ <b>D-PS10</b> -◇	<b>AR46M</b> □ <b>D-PS10</b> -◇
<b>AR46A</b> □ <b>D-PS25</b> -◇	<b>AR46M</b> □ <b>D-PS25</b> -◇
<b>AR46A</b> □ <b>D-PS36</b> -◇	<b>AR46M</b> □ <b>D-PS36</b> -◇
<b>AR46A</b> □ <b>D-PS50</b> -◇	<b>AR46M</b> □ <b>D-PS50</b> -◇
<b>AR66A</b> □ <b>D-PS5</b> -◇	<b>AR66M</b> □ <b>D-PS5</b> -◇
<b>AR66A</b> □ <b>D-PS7</b> -◇	<b>AR66M</b> □ <b>D-PS7</b> -◇
<b>AR66A</b> □ <b>D-PS10</b> -◇	<b>AR66M</b> □ <b>D-PS10</b> -◇
<b>AR66A</b> □ <b>D-PS25</b> -◇	<b>AR66M</b> □ <b>D-PS25</b> -◇
<b>AR66A</b> □ <b>D-PS36</b> -◇	<b>AR66M</b> □ <b>D-PS36</b> -◇
<b>AR66A</b> □ <b>D-PS50</b> -◇	<b>AR66M</b> □ <b>D-PS50</b> -◇
<b>AR98A</b> □ <b>D-PS5</b> -◇	<b>AR98M</b> □ <b>D-PS5</b> -◇
<b>AR98A</b> □ <b>D-PS7</b> -◇	<b>AR98M</b> □ <b>D-PS7</b> -◇
<b>AR98A</b> □ <b>D-PS10</b> -◇	<b>AR98M</b> □ <b>D-PS10</b> -◇
<b>AR98A</b> □ <b>D-PS25</b> -◇	<b>AR98M</b> □ <b>D-PS25</b> -◇
<b>AR98A</b> □ <b>D-PS36</b> -◇	<b>AR98M</b> □ <b>D-PS36</b> -◇
<b>AR98A</b> □ <b>D-PS50</b> -◇	<b>AR98M</b> □ <b>D-PS50</b> -◇

#### ◇ PN Geared Type

Product Name	Product Name
<b>AR46A</b> □ <b>D-N5</b> -◇	<b>AR46M</b> □ <b>D-N5</b> -◇
<b>AR46A</b> □ <b>D-N7.2</b> -◇	<b>AR46M</b> □ <b>D-N7.2</b> -◇
<b>AR46A</b> □ <b>D-N10</b> -◇	<b>AR46M</b> □ <b>D-N10</b> -◇
<b>AR66A</b> □ <b>D-N5</b> -◇	<b>AR66M</b> □ <b>D-N5</b> -◇
<b>AR66A</b> □ <b>D-N7.2</b> -◇	<b>AR66M</b> □ <b>D-N7.2</b> -◇
<b>AR66A</b> □ <b>D-N10</b> -◇	<b>AR66M</b> □ <b>D-N10</b> -◇
<b>AR66A</b> □ <b>D-N25</b> -◇	<b>AR66M</b> □ <b>D-N25</b> -◇
<b>AR66A</b> □ <b>D-N36</b> -◇	<b>AR66M</b> □ <b>D-N36</b> -◇
<b>AR66A</b> □ <b>D-N50</b> -◇	<b>AR66M</b> □ <b>D-N50</b> -◇
<b>AR98A</b> □ <b>D-N5</b> -◇	<b>AR98M</b> □ <b>D-N5</b> -◇
<b>AR98A</b> □ <b>D-N7.2</b> -◇	<b>AR98M</b> □ <b>D-N7.2</b> -◇
<b>AR98A</b> □ <b>D-N10</b> -◇	<b>AR98M</b> □ <b>D-N10</b> -◇
<b>AR98A</b> □ <b>D-N25</b> -◇	<b>AR98M</b> □ <b>D-N25</b> -◇
<b>AR98A</b> □ <b>D-N36</b> -◇	<b>AR98M</b> □ <b>D-N36</b> -◇
<b>AR98A</b> □ <b>D-N50</b> -◇	<b>AR98M</b> □ <b>D-N50</b> -◇

The following items are included in each product.

Motor, Shaft Parallel Key\*1, Driver, Cable for Motor, Cable for Electromagnetic Brake\*2, Connector for Input Signal, Connector for Output Signal, Connector for Sensor Signal, Connector for Regeneration Unit/Main Power Supply, Connector for 24 VDC Power Supply/Regeneration Unit Thermal Input/Electromagnetic Brake Output Terminal, Connector Wiring Lever, Operating Manual

● The product comes with a 1 m, 2 m or 3 m cable for motor and cable for electromagnetic brake\*2. If you need cables longer than 3 m or cables offering excellent flexibility, select appropriate cables from the accessories (sold separately).

\*1 Only for products with a key slot on the output shaft.

\*2 Only with Electromagnetic Brake Type.

● Pulse Input Package

◇ Standard Type

Product Name (Single shaft)	Product Name (Double shaft)
AR46A□◇	AR46B□◇
AR66A□◇	AR66B□◇
AR69A□◇	AR69B□◇
AR98A□◇	AR98B□◇
AR911A□◇	AR911B□◇

◇ Standard Type with Electromagnetic Brake

Product Name
AR46M□◇
AR66M□◇
AR69M□◇
AR98M□◇

◇ TH Geared Type

◇ TH Geared Type with Electromagnetic Brake

Product Name	Product Name
AR46A□-T3.6◇	AR46M□-T3.6◇
AR46A□-T7.2◇	AR46M□-T7.2◇
AR46A□-T10◇	AR46M□-T10◇
AR46A□-T20◇	AR46M□-T20◇
AR46A□-T30◇	AR46M□-T30◇
AR66A□-T3.6◇	AR66M□-T3.6◇
AR66A□-T7.2◇	AR66M□-T7.2◇
AR66A□-T10◇	AR66M□-T10◇
AR66A□-T20◇	AR66M□-T20◇
AR66A□-T30◇	AR66M□-T30◇
AR98A□-T3.6◇	AR98M□-T3.6◇
AR98A□-T7.2◇	AR98M□-T7.2◇
AR98A□-T10◇	AR98M□-T10◇
AR98A□-T20◇	AR98M□-T20◇
AR98A□-T30◇	AR98M□-T30◇

◇ Harmonic Geared Type

◇ Harmonic Geared Type with Electromagnetic Brake

Product Name	Product Name
AR46A□-H50◇	AR46M□-H50◇
AR46A□-H100◇	AR46M□-H100◇
AR66A□-H50◇	AR66M□-H50◇
AR66A□-H100◇	AR66M□-H100◇
AR98A□-H50◇	AR98M□-H50◇
AR98A□-H100◇	AR98M□-H100◇

● Either **A** (single-phase 100-115 VAC), **C** (single-phase 200-230 VAC) or **S** (three-phase 200-230 VAC) indicating the power supply input is entered where the box □ is located within the product name.

A number indicating the desired length of **1** (1 m), **2** (2 m) or **3** (3 m) for the cable included with the product is entered where the box ◇ is located within the product name. Select a desired cable length from 1 m, 2 m and 3 m.

The following items are included in each product.

Motor, Shaft Parallel Key\*1, Driver, Cable for Motor, Cable for Electromagnetic Brake\*2, Connector for I/O Signal, Connector for Regeneration Unit/Main Power Supply, Connector for 24 VDC Power Supply/Regeneration Unit Thermal Input/Electromagnetic Brake Output Terminal, Connector Wiring Lever, Operating Manual

● The product comes with a 1 m, 2 m or 3 m cable for motor and cable for electromagnetic brake\*2. If you need cables longer than 3 m or cables offering excellent flexibility, select appropriate cables from the accessories (sold separately).

\*1 Only for products with a key slot on the output shaft.

\*2 Only with Electromagnetic Brake Type.

◇ PS Geared Type

◇ PS Geared Type with Electromagnetic Brake

Product Name	Product Name
AR46A□-PS5◇	AR46M□-PS5◇
AR46A□-PS7◇	AR46M□-PS7◇
AR46A□-PS10◇	AR46M□-PS10◇
AR46A□-PS25◇	AR46M□-PS25◇
AR46A□-PS36◇	AR46M□-PS36◇
AR46A□-PS50◇	AR46M□-PS50◇
AR66A□-PS5◇	AR66M□-PS5◇
AR66A□-PS7◇	AR66M□-PS7◇
AR66A□-PS10◇	AR66M□-PS10◇
AR66A□-PS25◇	AR66M□-PS25◇
AR66A□-PS36◇	AR66M□-PS36◇
AR66A□-PS50◇	AR66M□-PS50◇
AR98A□-PS5◇	AR98M□-PS5◇
AR98A□-PS7◇	AR98M□-PS7◇
AR98A□-PS10◇	AR98M□-PS10◇
AR98A□-PS25◇	AR98M□-PS25◇
AR98A□-PS36◇	AR98M□-PS36◇
AR98A□-PS50◇	AR98M□-PS50◇

◇ PN Geared Type

◇ PN Geared Type with Electromagnetic Brake

Product Name	Product Name
AR46A□-N5◇	AR46M□-N5◇
AR46A□-N7.2◇	AR46M□-N7.2◇
AR46A□-N10◇	AR46M□-N10◇
AR66A□-N5◇	AR66M□-N5◇
AR66A□-N7.2◇	AR66M□-N7.2◇
AR66A□-N10◇	AR66M□-N10◇
AR66A□-N25◇	AR66M□-N25◇
AR66A□-N36◇	AR66M□-N36◇
AR66A□-N50◇	AR66M□-N50◇
AR98A□-N5◇	AR98M□-N5◇
AR98A□-N7.2◇	AR98M□-N7.2◇
AR98A□-N10◇	AR98M□-N10◇
AR98A□-N25◇	AR98M□-N25◇
AR98A□-N36◇	AR98M□-N36◇
AR98A□-N50◇	AR98M□-N50◇



## Step Angle 0.36° Frame Size 42 mm, 60 mm, 85 mm

### Standard Type

#### Specifications RoHS



Product Name	Built-In Controller Package	AR46□CD-◇	AR66□CD-◇	AR69□CD-◇	AR98□CD-◇	AR911□CD-◇	
	Pulse Input Package	AR46□C-◇	AR66□C-◇	AR69□C-◇	AR98□C-◇	AR911□C-◇	
Maximum Holding Torque	N·m	0.3	1.2		2	4	
Holding Torque at Motor Standstill	Power ON	N·m	0.15	0.6		1	2
	Electromagnetic Brake	N·m	0.15	0.6		1	—
Rotor Inertia	J: kg·m <sup>2</sup>	$58 \times 10^{-7}$ [ $73 \times 10^{-7}$ ]*2	$380 \times 10^{-7}$ [ $500 \times 10^{-7}$ ]*2	$750 \times 10^{-7}$ [ $870 \times 10^{-7}$ ]*2	$1100 \times 10^{-7}$ [ $1220 \times 10^{-7}$ ]*2	$2200 \times 10^{-7}$	
Resolution	Resolution Setting: 1000 P/R	0.36°/Pulse					
Degree of Protection		Motor: IP54: Single shaft type (Excluding the mounting surface and connector)		IP20: Double shaft type	Driver: IP20 (IP10)*3		
Power Supply Input	Voltage/Frequency	Built-In Controller Package		Single-Phase 200-240 VAC -15~+6% 50/60 Hz			
		Pulse Input Package		Single-Phase 200-230 VAC -15~+10% 50/60 Hz			
Control Power Supply	Maximum Input Current	1.9 (1.5)*3	2.7 (2.3)*3	3.8 (3)*3	3.4 (2.9)*3	4.1 (3.7)*3	
		24 VDC±5% 0.5A					
Electromagnetic Brake*4	Power Supply Input	24 VDC±5%*5 0.08A		24 VDC±5%*5 0.25A		—	

- Either **A** (single shaft), **B** (double shaft) or **M** (electromagnetic brake) indicating the configuration is entered where the box □ is located within the product name.
- Either **A** (single shaft), **B** (double shaft) indicating the configuration is entered where the box □ is located within the product name of **AR911**.
- A number indicating the desired length of **1** (1 m), **2** (2 m) or **3** (3 m) for the cable included with the product is entered where the box ◇ is located within the product name.
- \*1 Pulse input package only
- \*2 The values inside the brackets [ ] represent the specification for the electromagnetic brake type.
- \*3 The values inside the parentheses ( ) represent the specification for the built-in controller package.
- \*4 For pulse input package, a separate power supply for electromagnetic brakes is required.
- \*5 If the wiring distance between the motor and driver is extended to 20 m min. using an accessory cable (sold separately), the 24 VDC±4% specification applies.

#### Speed – Torque Characteristics

**AR46**

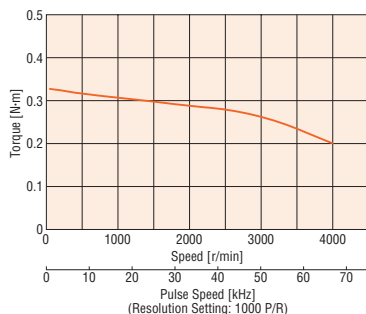

**AR66**

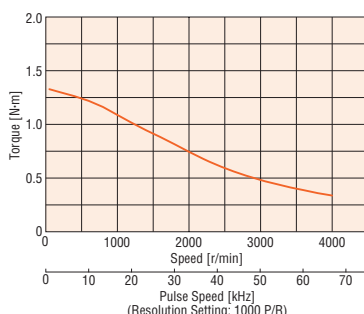

**AR69**

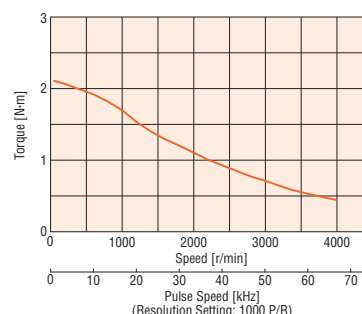

**AR98**

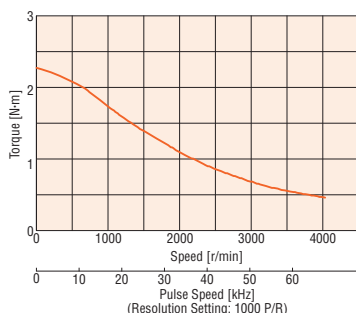

**AR911**

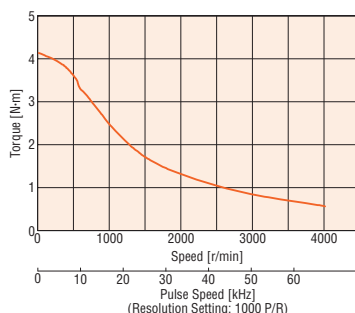

**Note**

● Pay attention to heat dissipation from the motor as there will be a considerable amount of heat under certain conditions. Be sure to keep the temperature of the motor case under 100°C.

# TH Geared Type Frame Size 42 mm

## Specifications RoHS



Product Name		Built-In Controller Package	AR46□CD-T3.6-◇	AR46□CD-T7.2-◇	AR46□CD-T10-◇	AR46□CD-T20-◇	AR46□CD-T30-◇	
		Pulse Input Package	AR46□C-T3.6-◇	AR46□C-T7.2-◇	AR46□C-T10-◇	AR46□C-T20-◇	AR46□C-T30-◇	
Maximum Holding Torque	N·m		0.35	0.7	1	1.5		
Rotor Inertia	J: kg·m <sup>2</sup>		58×10 <sup>-7</sup> [73×10 <sup>-7</sup> ]*2					
Gear Ratio			3.6	7.2	10	20	30	
Resolution	Resolution Setting: 1000 P/R		0.1°/Pulse	0.05°/Pulse	0.036°/Pulse	0.018°/Pulse	0.012°/Pulse	
Permissible Torque	N·m		0.35	0.7	1	1.5		
Holding Torque at Motor Standstill	Power ON	N·m	0.34	0.69	0.96	1.4	1.5	
	Electromagnetic Brake	N·m	0.34	0.69	0.96	1.4	1.5	
Permissible Speed Range	r/min		0~500	0~250	0~180	0~90	0~60	
Backlash	arc min (degrees)		45 (0.75°)	25 (0.42°)		15 (0.25°)		
Degree of Protection			Motor: IP54: Single shaft type (Excluding the mounting surface and connector) Driver: IP20 (IP10)*3					
Power Supply Input	Voltage/ Frequency	Built-In Controller Package	Single-Phase 200-240 VAC -15~+6% 50/60Hz					
		Pulse Input Package	Single-Phase 200-230 VAC -15~+10% 50/60Hz					
Control Power Supply		Maximum Input Current	1.9 (1.5)*3					
Electromagnetic Brake*4	Power Supply Input		24 VDC±5%*5		0.5A			
			24 VDC±5%*5		0.08A			

● Either **A** (single shaft) or **M** (electromagnetic brake) indicating the configuration is entered where the box □ is located within the product name.

A number indicating the desired length of **1** (1 m), **2** (2 m) or **3** (3 m) for the cable included with the product is entered where the box ◇ is located within the product name.

\*1 Pulse input package only

\*2 The values inside the brackets [ ] represent the specification for the electromagnetic brake type.

\*3 The values inside the parentheses ( ) represent the specification for the built-in controller package.

\*4 For pulse input package, a separate power supply for electromagnetic brakes is required.

\*5 If the wiring distance between the motor and driver is extended to 20 m min. using an accessory cable (sold separately), the 24 VDC±4% specification applies.

## Speed – Torque Characteristics

**AR46 Gear Ratio 3.6**

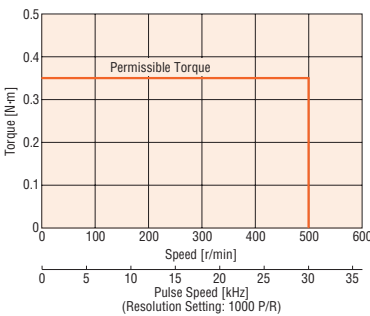

**AR46 Gear Ratio 7.2**

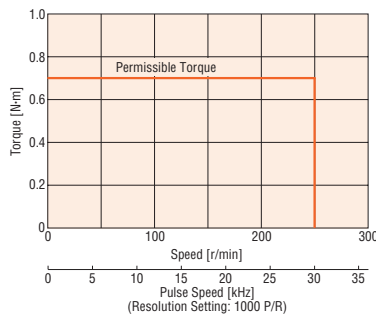

**AR46 Gear Ratio 10**

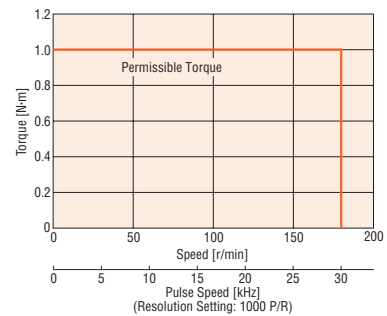

**AR46 Gear Ratio 20**

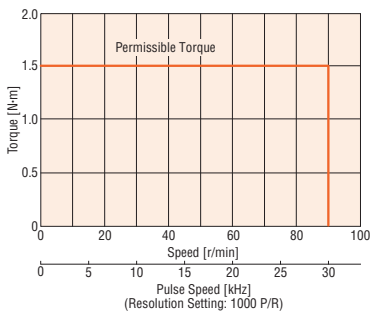

**AR46 Gear Ratio 30**

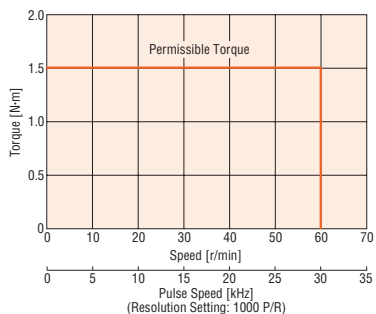

### Note

● Pay attention to heat dissipation from the motor as there will be a considerable amount of heat under certain conditions. Be sure to keep the temperature of the motor case under 100°C.



## TH Geared Type Frame Size 60 mm

### Specifications



Product Name	Built-In Controller Package Pulse Input Package	AR66□CD-T3.6-◇ AR66□C-T3.6-◇	AR66□CD-T7.2-◇ AR66□C-T7.2-◇	AR66□CD-T10-◇ AR66□C-T10-◇	AR66□CD-T20-◇ AR66□C-T20-◇	AR66□CD-T30-◇ AR66□C-T30-◇
Maximum Holding Torque	N·m	1.25	2.5	3	3.5	4
Rotor Inertia	J: kg·m <sup>2</sup>	380×10 <sup>-7</sup> [500×10 <sup>-7</sup> ]*2				
Gear Ratio		3.6	7.2	10	20	30
Resolution	Resolution Setting: 1000 P/R	0.1°/Pulse	0.05°/Pulse	0.036°/Pulse	0.018°/Pulse	0.012°/Pulse
Permissible Torque	N·m	1.25	2.5	3	3.5	4
Holding Torque at Motor Standstill	Power ON Electromagnetic Brake	N·m N·m	1.25 2.5	3 3	3.5 3.5	4 4
Permissible Speed Range	r/min	0~500	0~250	0~180	0~90	0~60
Backlash	arc min (degrees)	35 (0.59°)	15 (0.25°)		10 (0.17°)	
Degree of Protection		Motor: IP54: Single shaft type (Excluding the mounting surface and connector) Driver: IP20 (IP10)*3				
Power Supply Input	Voltage/ Frequency	Built-In Controller Package	Single-Phase 200-240 VAC -15~+6% 50/60Hz			
	Pulse Input Package	Single-Phase 200-230 VAC -15~+10% 50/60Hz				
	Maximum Input Current	A				
Control Power Supply		24 VDC±5% 0.5A				
Electromagnetic Brake*4	Power Supply Input	24 VDC±5%*5 0.25A				

● Either **A** (single shaft) or **M** (electromagnetic brake) indicating the configuration is entered where the box □ is located within the product name.

A number indicating the desired length of **1** (1 m), **2** (2 m) or **3** (3 m) for the cable included with the product is entered where the box ◇ is located within the product name.

\*1 Pulse input package only

\*2 The values inside the brackets [ ] represent the specification for the electromagnetic brake type.

\*3 The values inside the parentheses ( ) represent the specification for the built-in controller package.

\*4 For pulse input package, a separate power supply for electromagnetic brakes is required.

\*5 If the wiring distance between the motor and driver is extended to 20 m min. using an accessory cable (sold separately), the 24 VDC±4% specification applies.

### Speed – Torque Characteristics

**AR66 Gear Ratio 3.6**

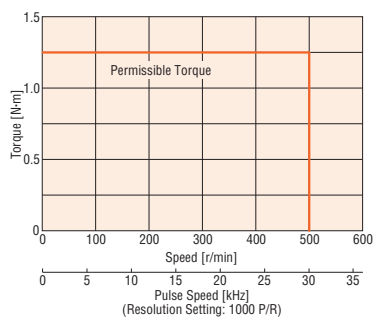

**AR66 Gear Ratio 7.2**

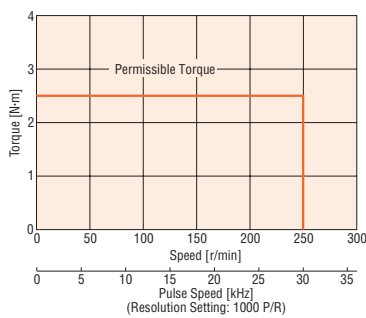

**AR66 Gear Ratio 10**

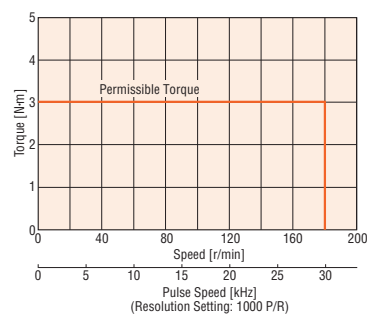

**AR66 Gear Ratio 20**

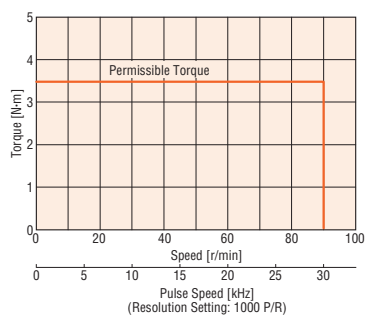

**AR66 Gear Ratio 30**

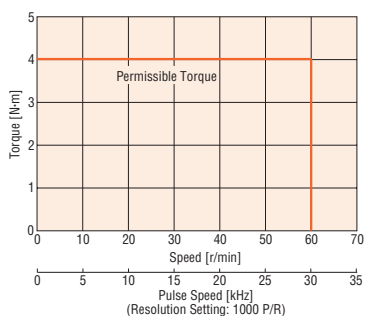

#### Note

● Pay attention to heat dissipation from the motor as there will be a considerable amount of heat under certain conditions. Be sure to keep the temperature of the motor case under 100°C.

Introduction  
0.36°/Geared  
C-SSR-  
AR  
AC Input Motor & Driver  
0.72°/Geared  
RK  
0.36°/Geared  
C-SSR-  
AR  
0.36°/0.72°/  
Geared  
CRK  
DC Input Motor & Driver  
1.8°/Geared  
RRK  
0.9°/1.8°/Geared  
CMK  
0.72°  
PK  
1.8°/Geared  
High-Torque  
PKP  
Motor Only  
0.9°/1.8°/Geared  
PK  
Controllers  
SG80301Y  
Accessories

# TH Geared Type Frame Size 90 mm

## Specifications RoHS



Product Name		Built-In Controller Package	AR98□CD-T3.6-◇	AR98□CD-T7.2-◇	AR98□CD-T10-◇	AR98□CD-T20-◇	AR98□CD-T30-◇	
		Pulse Input Package	AR98□C-T3.6-◇	AR98□C-T7.2-◇	AR98□C-T10-◇	AR98□C-T20-◇	AR98□C-T30-◇	
Maximum Holding Torque	N·m		4.5		9		12	
Rotor Inertia	J: kg·m <sup>2</sup>		1100×10 <sup>-7</sup> [1220×10 <sup>-7</sup> ]*2					
Gear Ratio			3.6	7.2	10	20	30	
Resolution	Resolution Setting: 1000 P/R		0.1°/Pulse	0.05°/Pulse	0.036°/Pulse	0.018°/Pulse	0.012°/Pulse	
Permissible Torque	N·m		4.5		9		12	
Holding Torque at Power ON	N·m		3.6	7.2	9	10	12	
Motor Standstill Electromagnetic Brake	N·m		3.6	7.2	9	10	12	
Permissible Speed Range	r/min		0~500	0~250	0~180	0~90	0~60	
Backlash	arc min (degrees)		25 (0.42°)	15 (0.25°)		10 (0.17°)		
Degree of Protection			Motor: IP54: Single shaft type (Excluding the mounting surface and connector) Driver: IP20 (IP10)*3					
Power Supply Input	Voltage/ Frequency	Built-In Controller Package	Single-Phase 200-240 VAC -15~+6% 50/60Hz					
		Pulse Input Package	Single-Phase 200-230 VAC -15~+10% 50/60Hz					
	Maximum Input Current	A	3.4 (2.9)*3					
Control Power Supply			24 VDC±5% 0.5A					
Electromagnetic Brake*4	Power Supply Input		24 VDC±5%*5 0.25A					

- Either **A** (single shaft) or **M** (electromagnetic brake) indicating the configuration is entered where the box □ is located within the product name.
- A number indicating the desired length of **1** (1 m), **2** (2 m) or **3** (3 m) for the cable included with the product is entered where the box ◇ is located within the product name.
- \*1 Pulse input package only
- \*2 The values inside the brackets [ ] represent the specification for the electromagnetic brake type.
- \*3 The values inside the parentheses ( ) represent the specification for the built-in controller package.
- \*4 For pulse input package, a separate power supply for electromagnetic brakes is required.
- \*5 If the wiring distance between the motor and driver is extended to 20 m min. using an accessory cable (sold separately), the 24 VDC±4% specification applies.

## Speed – Torque Characteristics

**AR98 Gear Ratio 3.6**

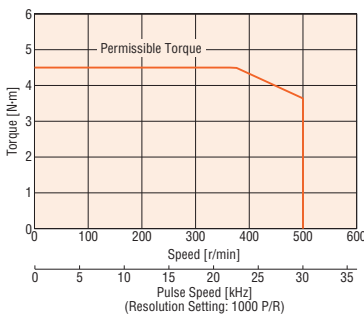

**AR98 Gear Ratio 7.2**

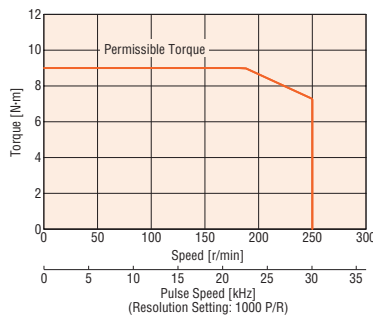

**AR98 Gear Ratio 10**

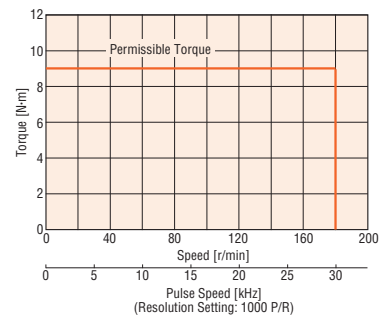

**AR98 Gear Ratio 20**

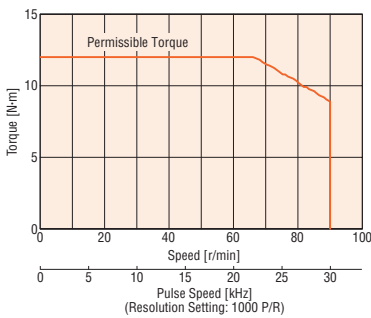

**AR98 Gear Ratio 30**

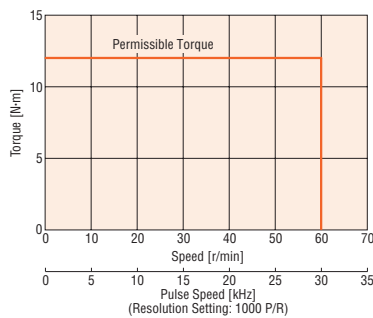

### Note

- Pay attention to heat dissipation from the motor as there will be a considerable amount of heat under certain conditions. Be sure to keep the temperature of the motor case under 100°C.

## PS Geared Type Frame Size 42 mm

### Specifications



Product Name	Built-In Controller Package	AR46□CD-PS5-◇	AR46□CD-PS7-◇	AR46□CD-PS10-◇	AR46□CD-PS25-◇	AR46□CD-PS36-◇	AR46□CD-PS50-◇
	Pulse Input Package	AR46□C-PS5-◇	AR46□C-PS7-◇	AR46□C-PS10-◇	AR46□C-PS25-◇	AR46□C-PS36-◇	AR46□C-PS50-◇
Maximum Holding Torque	N·m	1	1.5		2.5		3
Rotor Inertia	J: kg·m <sup>2</sup>	58×10 <sup>-7</sup> [73×10 <sup>-7</sup> ]*2					
Gear Ratio		5	7.2	10	25	36	50
Resolution	Resolution Setting: 1000 P/R	0.072°/Pulse	0.05°/Pulse	0.036°/Pulse	0.0144°/Pulse	0.01°/Pulse	0.0072°/Pulse
Permissible Torque	N·m	1	1.5		2.5		3
Maximum Torque	N·m	1.5	2		6		
Holding Torque at Motor Standstill	Power ON	N·m	0.75	1	1.5	2.5	3
	Electromagnetic Brake	N·m	0.75	1	1.5	2.5	3
Permissible Speed Range	r/min	0~600	0~416	0~300	0~120	0~83	0~60
Backlash	arc min (degrees)	25 (0.42°)					
Degree of Protection		Motor: IP54: Single shaft type (Excluding the mounting surface and connector) Driver: IP20 (IP10)*3					
Power Supply Input	Voltage/Frequency	Single-Phase 200-240 VAC -15~+6% 50/60Hz					
	Pulse Input Package	Single-Phase 200-230 VAC -15~+10% 50/60Hz					
	Maximum Input Current	A 1.9 (1.5)*3					
Control Power Supply		24 VDC±5% 0.5A					
Electromagnetic Brake*4	Power Supply Input	24 VDC±5%*5 0.08A					

● Either **A** (single shaft) or **M** (electromagnetic brake) indicating the configuration is entered where the box □ is located within the product name.

▲ A number indicating the desired length of **1** (1 m), **2** (2 m) or **3** (3 m) for the cable included with the product is entered where the box ◇ is located within the product name.

\*1 Pulse input package only

\*2 The values inside the brackets [ ] represent the specification for the electromagnetic brake type.

\*3 The values inside the parentheses ( ) represent the specification for the built-in controller package.

\*4 For pulse input package, a separate power supply for electromagnetic brakes is required.

\*5 If the wiring distance between the motor and driver is extended to 20 m min. using an accessory cable (sold separately), the 24 VDC±4% specification applies.

### Speed – Torque Characteristics

**AR46 Gear Ratio 5**

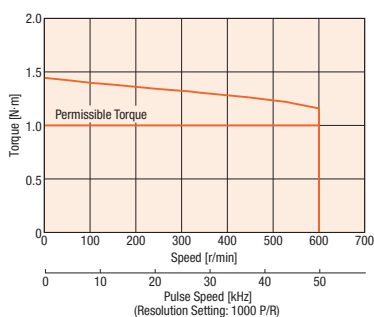

**AR46 Gear Ratio 7.2**

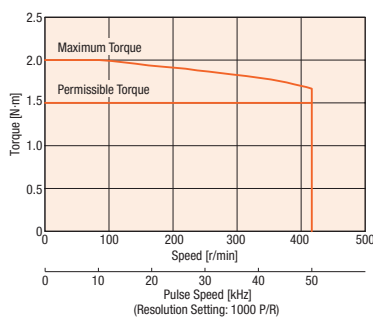

**AR46 Gear Ratio 10**

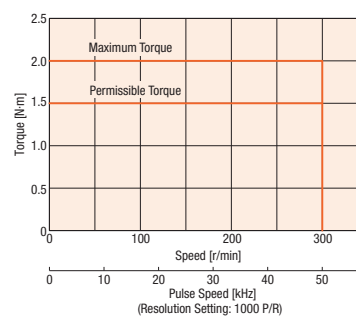

**AR46 Gear Ratio 25**

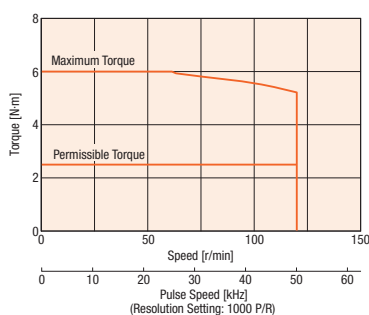

**AR46 Gear Ratio 36**

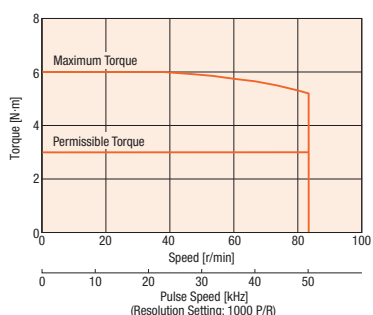

**AR46 Gear Ratio 50**

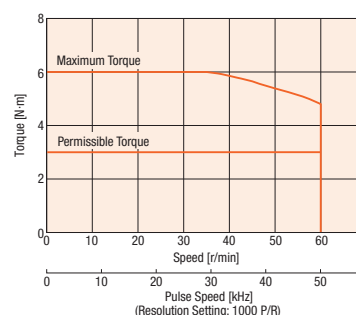

#### Note

● Pay attention to heat dissipation from the motor as there will be a considerable amount of heat under certain conditions. Be sure to keep the temperature of the motor case under 100°C.

Introduction  
0.36°/Geared  
C-Size  
AR  
AC Input Motor & Driver  
0.72°/Geared  
RK  
0.36°/Geared  
C-Size  
AR  
DC Input Motor & Driver  
0.36°/0.72°/  
Geared  
CRK  
1.8°/Geared  
RRK  
0.9°/1.8°/Geared  
CMK  
0.72°  
PK  
1.8°/Geared  
High-Torque  
PKP  
Motor Only  
0.9°/1.8°/Geared  
PK  
Controllers  
SG80301Y  
Accessories

# PS Geared Type Frame Size 60 mm

## Specifications RoHS



Product Name	Built-In Controller Package	AR66□CD-PS5-◇	AR66□CD-PS7-◇	AR66□CD-PS10-◇	AR66□CD-PS25-◇	AR66□CD-PS36-◇	AR66□CD-PS50-◇	
	Pulse Input Package	AR66□C-PS5-◇	AR66□C-PS7-◇	AR66□C-PS10-◇	AR66□C-PS25-◇	AR66□C-PS36-◇	AR66□C-PS50-◇	
Maximum Holding Torque	N·m	3.5	4	5	8			
Rotor Inertia	J: kg·m <sup>2</sup>	380×10 <sup>-7</sup> [500×10 <sup>-7</sup> ]*2						
Gear Ratio		5	7.2	10	25	36	50	
Resolution	Resolution Setting: 1000 P/R	0.072°/Pulse	0.05°/Pulse	0.036°/Pulse	0.0144°/Pulse	0.01°/Pulse	0.0072°/Pulse	
Permissible Torque	N·m	3.5	4	5	8			
Maximum Torque	N·m	7	9	11	16	20		
Holding Torque at Motor Standstill	Power ON	3	4	5	8			
	Electromagnetic Brake	3	4	5	8			
Permissible Speed Range	r/min	0~600	0~416	0~300	0~120	0~83	0~60	
Backlash	arc min (degrees)	15 (0.25°)						
Degree of Protection		Motor: IP54: Single shaft type (Excluding the mounting surface and connector) Driver: IP20 (IP10)*3						
Power Supply Input	Voltage/ Frequency	Single-Phase 200-240 VAC -15~+6% 50/60Hz						
	Pulse Input Package	Single-Phase 200-230 VAC -15~+10% 50/60Hz						
	Maximum Input Current	2.7 (2.3)*3 A						
Control Power Supply		24 VDC±5% 0.5A						
Electromagnetic Brake*4	Power Supply Input	24 VDC±5%*5 0.25A						

- Either **A** (single shaft) or **M** (electromagnetic brake) indicating the configuration is entered where the box □ is located within the product name.
- A number indicating the desired length of **1** (1 m), **2** (2 m) or **3** (3 m) for the cable included with the product is entered where the box ◇ is located within the product name.
- \*1 Pulse input package only
- \*2 The values inside the brackets [ ] represent the specification for the electromagnetic brake type.
- \*3 The values inside the parentheses ( ) represent the specification for the built-in controller package.
- \*4 For pulse input package, a separate power supply for electromagnetic brakes is required.
- \*5 If the wiring distance between the motor and driver is extended to 20 m min. using an accessory cable (sold separately), the 24 VDC±4% specification applies.

## Speed – Torque Characteristics

**AR66 Gear Ratio 5**

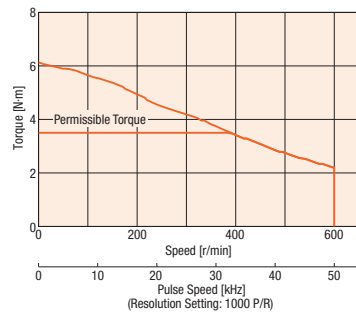

**AR66 Gear Ratio 7.2**

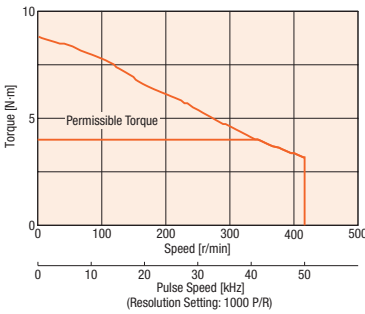

**AR66 Gear Ratio 10**

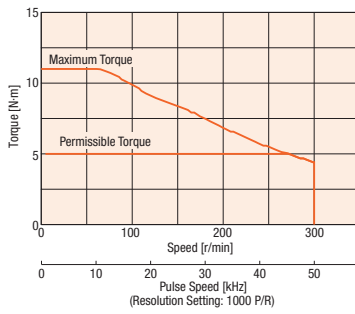

**AR66 Gear Ratio 25**

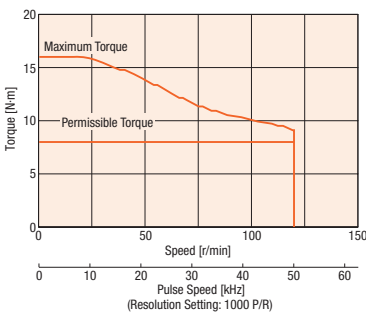

**AR66 Gear Ratio 36**

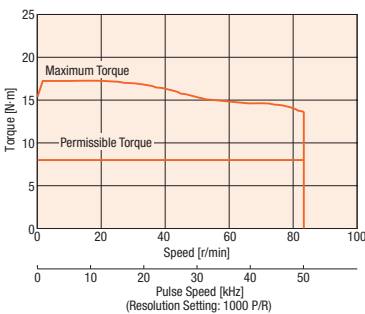

**AR66 Gear Ratio 50**

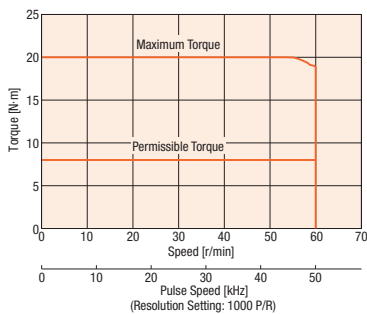

**Note**

● Pay attention to heat dissipation from the motor as there will be a considerable amount of heat under certain conditions. Be sure to keep the temperature of the motor case under 100°C.

## PS Geared Type Frame Size 90 mm

### Specifications



Product Name	Built-In Controller Package	AR98□CD-PS5-◇	AR98□CD-PS7-◇	AR98□CD-PS10-◇	AR98□CD-PS25-◇	AR98□CD-PS36-◇	AR98□CD-PS50-◇	
	Pulse Input Package	AR98□C-PS5-◇	AR98□C-PS7-◇	AR98□C-PS10-◇	AR98□C-PS25-◇	AR98□C-PS36-◇	AR98□C-PS50-◇	
Maximum Holding Torque	N·m	10	14	20		37		
Rotor Inertia	J: kg·m <sup>2</sup>	1100×10 <sup>-7</sup> [1220×10 <sup>-7</sup> ]*2						
Gear Ratio		5	7.2	10	25	36	50	
Resolution	Resolution Setting: 1000 P/R	0.072°/Pulse	0.05°/Pulse	0.036°/Pulse	0.0144°/Pulse	0.01°/Pulse	0.0072°/Pulse	
Permissible Torque	N·m	10	14	20	37			
Maximum Torque	N·m	28	35		56	60		
Holding Torque at Motor Standstill	Power ON	5	7.2	10	25	36	37	
	Electromagnetic Brake	5	7.2	10	25	36	37	
Permissible Speed Range	r/min	0~600	0~416	0~300	0~120	0~83	0~60	
Backlash	arc min (degrees)	15 (0.25°)						
Degree of Protection		Motor: IP54: Single shaft type (Excluding the mounting surface and connector) Driver: IP20 (IP10)*3						
Power Supply Input	Voltage/Frequency	Single-Phase 200-240 VAC -15~+6% 50/60Hz						
	Pulse Input Package	Single-Phase 200-230 VAC -15~+10% 50/60Hz						
	Maximum Input Current	3.4 (2.9)*3						
Control Power Supply		24 VDC±5%		0.5A				
Electromagnetic Brake*4	Power Supply Input	24 VDC±5%*5		0.25A				

● Either **A** (single shaft) or **M** (electromagnetic brake) indicating the configuration is entered where the box □ is located within the product name.

▲ A number indicating the desired length of **1** (1 m), **2** (2 m) or **3** (3 m) for the cable included with the product is entered where the box ◇ is located within the product name.

\*1 Pulse input package only

\*2 The values inside the brackets [ ] represent the specification for the electromagnetic brake type.

\*3 The values inside the parentheses ( ) represent the specification for the built-in controller package.

\*4 For pulse input package, a separate power supply for electromagnetic brakes is required.

\*5 If the wiring distance between the motor and driver is extended to 20 m min. using an accessory cable (sold separately), the 24 VDC±4% specification applies.

### Speed – Torque Characteristics

**AR98 Gear Ratio 5**

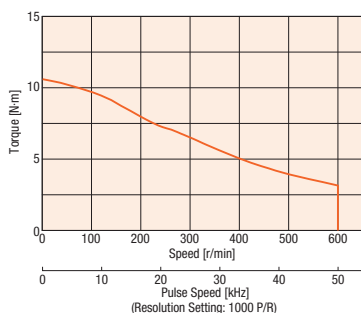

**AR98 Gear Ratio 7.2**

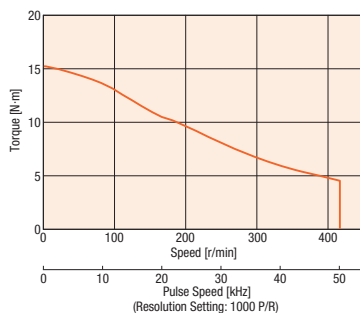

**AR98 Gear Ratio 10**

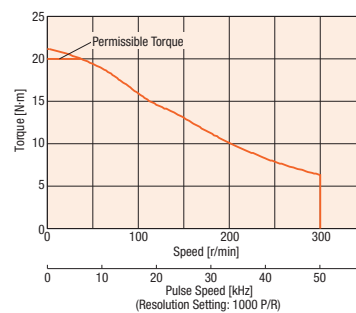

**AR98 Gear Ratio 25**

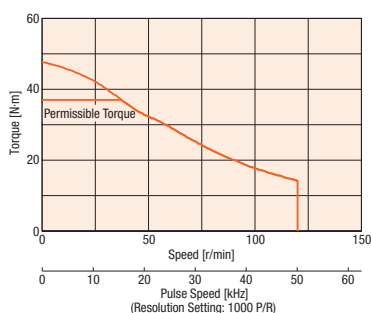

**AR98 Gear Ratio 36**

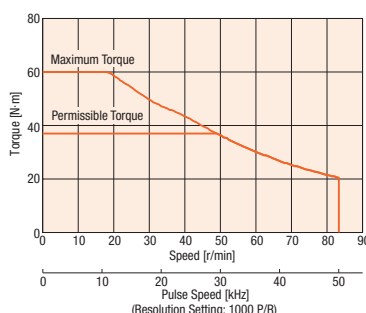

**AR98 Gear Ratio 50**

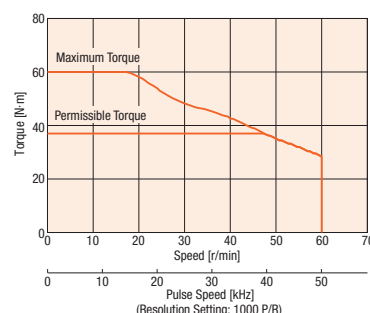

#### Note

● Pay attention to heat dissipation from the motor as there will be a considerable amount of heat under certain conditions. Be sure to keep the temperature of the motor case under 100°C.

# PN Geared Type Frame Size 42 mm

## Specifications RoHS



Product Name		Built-In Controller Package	<b>AR46□CD-N5-◇</b>	<b>AR46□CD-N7.2-◇</b>	<b>AR46□CD-N10-◇</b>
		Pulse Input Package	<b>AR46□C-N5-◇</b>	<b>AR46□C-N7.2-◇</b>	<b>AR46□C-N10-◇</b>
Maximum Holding Torque	N·m		1.35		1.5
Rotor Inertia	J: kg·m <sup>2</sup>		58×10 <sup>-7</sup> [73×10 <sup>-7</sup> ]*2		
Gear Ratio			5	7.2	10
Resolution	Resolution Setting: 1000 P/R		0.072°/Pulse	0.05°/Pulse	0.036°/Pulse
Permissible Torque	N·m		1.35		1.5
Maximum Torque	N·m		1.5		2
Holding Torque at Motor Standstill	Power ON		0.75	1	1.5
	Electromagnetic Brake		0.75	1	1.5
Permissible Speed Range	r/min		0~600	0~416	0~300
Backlash	arc min (degrees)		2 (0.034°)		
Degree of Protection			Motor: IP54: Single shaft type (Excluding the mounting surface and connector) Driver: IP20 (IP10)*3		
Power Supply Input	Voltage/Frequency	Built-In Controller Package	Single-Phase 200-240 VAC -15~+6% 50/60Hz		
		Pulse Input Package	Single-Phase 200-230 VAC -15~+10% 50/60Hz		
	Maximum Input Current	A	1.9 (1.5)*3		
Control Power Supply			24 VDC±5%	0.5A	
Electromagnetic Brake*4	Power Supply Input		24 VDC±5%*5	0.08A	

- Either **A** (single shaft) or **M** (electromagnetic brake) indicating the configuration is entered where the box □ is located within the product name.
- A number indicating the desired length of **1** (1 m), **2** (2 m) or **3** (3 m) for the cable included with the product is entered where the box ◇ is located within the product name.
- \*1 Pulse input package only
- \*2 The values inside the brackets [ ] represent the specification for the electromagnetic brake type.
- \*3 The values inside the parentheses ( ) represent the specification for the built-in controller package.
- \*4 For pulse input package, a separate power supply for electromagnetic brakes is required.
- \*5 If the wiring distance between the motor and driver is extended to 20 m min. using an accessory cable (sold separately), the 24 VDC±4% specification applies.

## Speed – Torque Characteristics

**AR46 Gear Ratio 5**

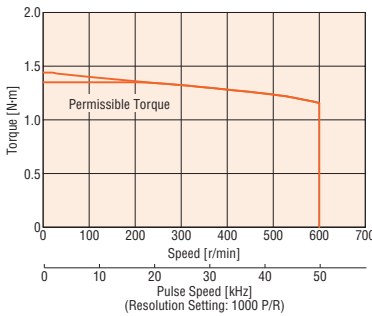

**AR46 Gear Ratio 7.2**

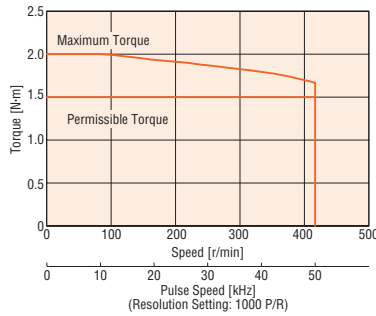

**AR46 Gear Ratio 10**

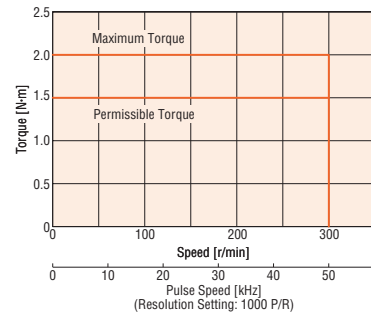

**Note**

- Pay attention to heat dissipation from the motor as there will be a considerable amount of heat under certain conditions. Be sure to keep the temperature of the motor case under 100°C.

## PN Geared Type Frame Size 60 mm

### Specifications



Product Name	Built-In Controller Package Pulse Input Package	AR66□CD-N5-◇ AR66□C-N5-◇	AR66□CD-N7.2-◇ AR66□C-N7.2-◇	AR66□CD-N10-◇ AR66□C-N10-◇	AR66□CD-N25-◇ AR66□C-N25-◇	AR66□CD-N36-◇ AR66□C-N36-◇	AR66□CD-N50-◇ AR66□C-N50-◇
Maximum Holding Torque	N·m	3.5	4	5	8		
Rotor Inertia	J: kg·m <sup>2</sup>	380×10 <sup>-7</sup> [500×10 <sup>-7</sup> ]*2					
Gear Ratio		5	7.2	10	25	36	50
Resolution	Resolution Setting: 1000 P/R	0.072°/Pulse	0.05°/Pulse	0.036°/Pulse	0.0144°/Pulse	0.01°/Pulse	0.0072°/Pulse
Permissible Torque	N·m	3.5	4	5	8		
Maximum Torque	N·m	7	9	11	16	20	
Holding Torque at Motor Standstill	Power ON Electromagnetic Brake	N·m N·m	3 4	4 5	5	8	
Permissible Speed Range	r/min	0~600	0~416	0~300	0~120	0~83	0~60
Backlash	arc min (degrees)	2 (0.034°)			3 (0.05°)		
Degree of Protection	Motor: IP54: Single shaft type (Excluding the mounting surface and connector) Driver: IP20 (IP10)*3						
Power Supply Input	Voltage/ Frequency	Built-In Controller Package Pulse Input Package	Single-Phase 200-240 VAC -15~+6% 50/60Hz Single-Phase 200-230 VAC -15~+10% 50/60Hz				
Control Power Supply	Maximum Input Current	A	2.7 (2.3)*3				
Electromagnetic Brake*4	Power Supply Input		24 VDC±5%*5 0.25A				

● Either **A** (single shaft) or **M** (electromagnetic brake) indicating the configuration is entered where the box □ is located within the product name.

● A number indicating the desired length of **1** (1 m), **2** (2 m) or **3** (3 m) for the cable included with the product is entered where the box ◇ is located within the product name.

\*1 Pulse input package only

\*2 The values inside the brackets [ ] represent the specification for the electromagnetic brake type.

\*3 The values inside the parentheses ( ) represent the specification for the built-in controller package.

\*4 For pulse input package, a separate power supply for electromagnetic brakes is required.

\*5 If the wiring distance between the motor and driver is extended to 20 m min. using an accessory cable (sold separately), the 24 VDC±4% specification applies.

### Speed – Torque Characteristics

**AR66 Gear Ratio 5**

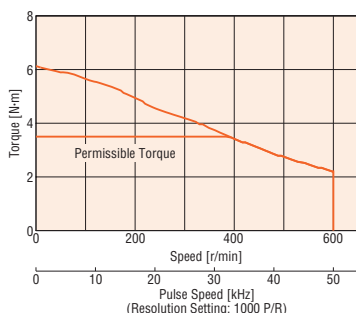

**AR66 Gear Ratio 7.2**

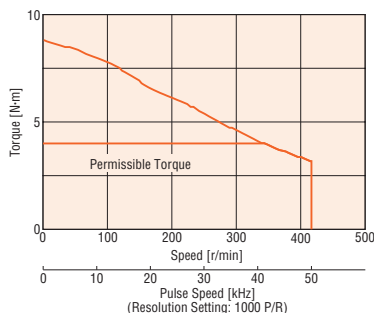

**AR66 Gear Ratio 10**

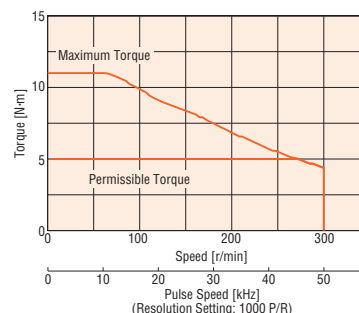

**AR66 Gear Ratio 25**

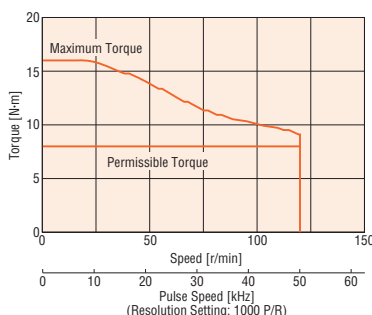

**AR66 Gear Ratio 36**

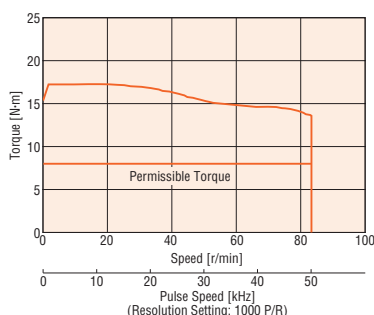

**AR66 Gear Ratio 50**

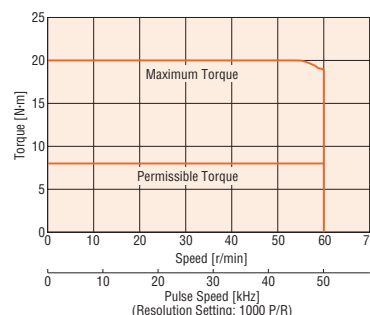

#### Note

● Pay attention to heat dissipation from the motor as there will be a considerable amount of heat under certain conditions. Be sure to keep the temperature of the motor case under 100°C.



# PN Geared Type Frame Size 90 mm

## Specifications RoHS



Product Name		Built-In Controller Package	AR98□CD-N5-◇	AR98□CD-N7.2-◇	AR98□CD-N10-◇	AR98□CD-N25-◇	AR98□CD-N36-◇	AR98□CD-N50-◇
		Pulse Input Package	AR98□C-N5-◇	AR98□C-N7.2-◇	AR98□C-N10-◇	AR98□C-N25-◇	AR98□C-N36-◇	AR98□C-N50-◇
Maximum Holding Torque	N·m		10	14	20		37	
Rotor Inertia	J: kg·m <sup>2</sup>		1100×10 <sup>-7</sup> [1220×10 <sup>-7</sup> ]*2					
Gear Ratio			5	7.2	10	25	36	50
Resolution	Resolution Setting: 1000 P/R		0.072°/Pulse	0.05°/Pulse	0.036°/Pulse	0.0144°/Pulse	0.01°/Pulse	0.0072°/Pulse
Permissible Torque	N·m		10	14	20	37		
Maximum Torque	N·m		28	35		56	60	
Holding Torque at Motor Standstill	Power ON	N·m	5	7.2	10	25	36	37
	Electromagnetic Brake	N·m	5	7.2	10	25	36	37
Permissible Speed Range	r/min		0~600	0~416	0~300	0~120	0~83	0~60
Backlash	arc min (degrees)		2 (0.034°)			3 (0.05°)		
Degree of Protection			Motor: IP54: Single shaft type (Excluding the mounting surface and connector) Driver: IP20 (IP10)*3					
Power Supply Input	Voltage/ Frequency	Built-In Controller Package	Single-Phase 200-240 VAC -15~+6% 50/60Hz					
		Pulse Input Package	Single-Phase 200-230 VAC -15~+10% 50/60Hz					
		Maximum Input Current	3.4 (2.9)*3 A					
Control Power Supply			24 VDC±5% 0.5A					
Electromagnetic Brake*4	Power Supply Input		24 VDC±5%*5 0.25A					

- Either **A** (single shaft) or **M** (electromagnetic brake) indicating the configuration is entered where the box □ is located within the product name.
- A number indicating the desired length of **1** (1 m), **2** (2 m) or **3** (3 m) for the cable included with the product is entered where the box ◇ is located within the product name.
- \*1 Pulse input package only
- \*2 The values inside the brackets [ ] represent the specification for the electromagnetic brake type.
- \*3 The values inside the parentheses ( ) represent the specification for the built-in controller package.
- \*4 For pulse input package, a separate power supply for electromagnetic brakes is required.
- \*5 If the wiring distance between the motor and driver is extended to 20 m min. using an accessory cable (sold separately), the 24 VDC±4% specification applies.

## Speed – Torque Characteristics

**AR98 Gear Ratio 5**

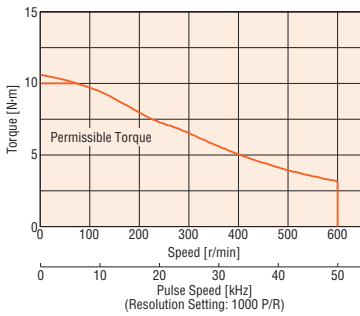

**AR98 Gear Ratio 7.2**

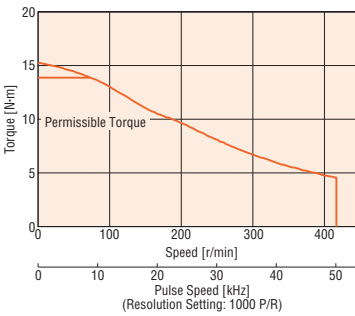

**AR98 Gear Ratio 10**

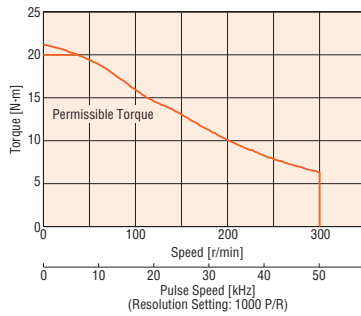

**AR98 Gear Ratio 25**

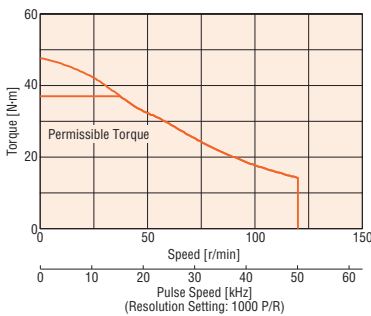

**AR98 Gear Ratio 36**

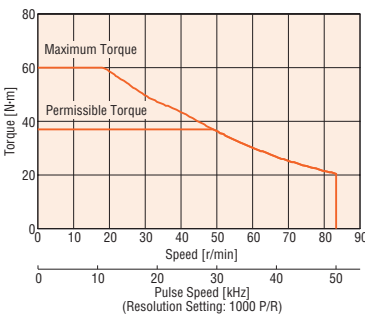

**AR98 Gear Ratio 50**

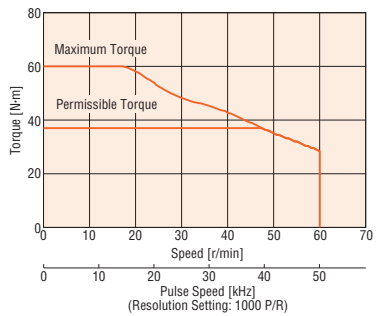

**Note**

● Pay attention to heat dissipation from the motor as there will be a considerable amount of heat under certain conditions. Be sure to keep the temperature of the motor case under 100°C.



## Harmonic Geared Type Frame Size 42 mm, 60 mm, 90 mm

### Specifications



Product Name	Built-In Controller Package		AR46□CD-H50◇	AR46□CD-H100◇	AR66□CD-H50◇	AR66□CD-H100◇	AR98□CD-H50◇	AR98□CD-H100◇
	Pulse Input Package		AR46□C-H50◇	AR46□C-H100◇	AR66□C-H50◇	AR66□C-H100◇	AR98□C-H50◇	AR98□C-H100◇
Maximum Holding Torque	N·m		3.5	5	5.5	8	25	37
Rotor Inertia	J: kg·m <sup>2</sup>		75×10 <sup>-7</sup> [90×10 <sup>-7</sup> ]*2		415×10 <sup>-7</sup> [535×10 <sup>-7</sup> ]*2		1300×10 <sup>-7</sup> [1420×10 <sup>-7</sup> ]*2	
Gear Ratio			50	100	50	100	50	100
Resolution	Resolution Setting: 1000 P/R		0.0072°/Pulse	0.0036°/Pulse	0.0072°/Pulse	0.0036°/Pulse	0.0072°/Pulse	0.0036°/Pulse
Permissible Torque	N·m		3.5	5	5.5	8	25	37
Maximum Torque	N·m		8.3	11	18	28	35	55
Holding Torque at Motor Standstill	Power ON	N·m	3.5	5	5.5	8	25	37
	Electromagnetic Brake	N·m	3.5	5	5.5	8	25	37
Permissible Speed Range	r/min		0~70	0~35	0~70	0~35	0~70	0~35
Lost Motion (Load Torque)	arc min		1.5 max. (±0.16 N·m)	1.5 max. (±0.2 N·m)	0.7 max. (±0.28 N·m)	0.7 max. (±0.39 N·m)	1.5 max. (±1.2 N·m)	
Degree of Protection	Motor: IP54: Single shaft type (Excluding the mounting surface and connector) Driver: IP20 (IP10)*3							
Power Supply Input	Voltage/Frequency	Built-In Controller Package	Single-Phase 200-240 VAC -15~+6% 50/60Hz					
		Pulse Input Package	Single-Phase 200-230 VAC -15~+10% 50/60Hz					
		Maximum Input Current	A 1.9 (1.5)*3		2.7 (2.3)*3		3.4 (2.9)*3	
Control Power Supply			24 VDC±5% 0.5A					
Electromagnetic Brake*4	Power Supply Input		24 VDC±5%*5 0.08A			24 VDC±5%*5 0.25A		

- Either **A** (single shaft) or **M** (electromagnetic brake) indicating the configuration is entered where the box □ is located within the product name.  
A number indicating the desired length of **1** (1 m), **2** (2 m) or **3** (3 m) for the cable included with the product is entered where the box ◇ is located within the product name.
- \*1 Pulse input package only
- \*2 The values inside the brackets [ ] represent the specification for the electromagnetic brake type.
- \*3 The values inside the parentheses ( ) represent the specification for the built-in controller package.
- \*4 For pulse input package, a separate power supply for electromagnetic brakes is required.
- \*5 If the wiring distance between the motor and driver is extended to 20 m min. using an accessory cable (sold separately), the 24 VDC±4% specification applies.

### Speed – Torque Characteristics

**AR46 Gear Ratio 50**

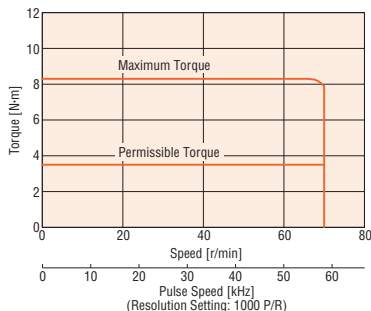

**AR66 Gear Ratio 50**

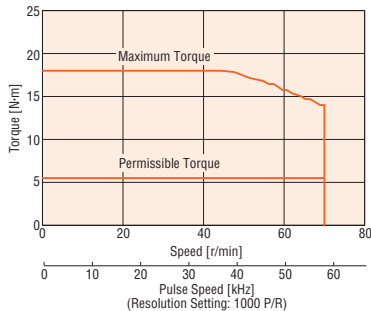

**AR98 Gear Ratio 50**

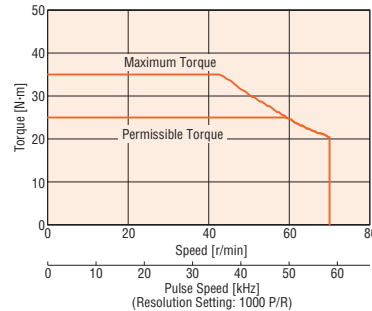

**AR46 Gear Ratio 100**

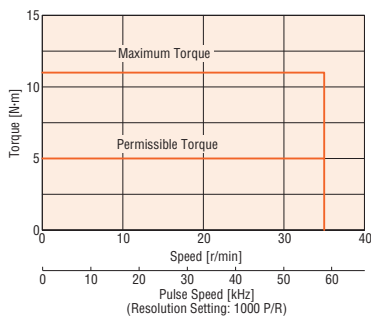

**AR66 Gear Ratio 100**

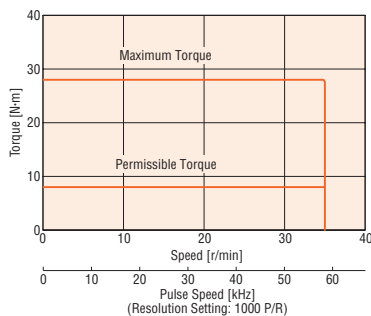

**AR98 Gear Ratio 100**

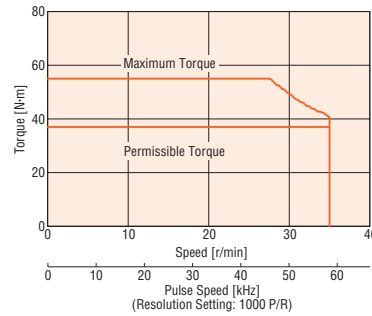

**Note**

- Pay attention to heat dissipation from the motor as there will be a considerable amount of heat under certain conditions. Be sure to keep the temperature of the motor case under 100°C.
- In order to prevent deterioration of the gear grease in the harmonic geared type, keep the temperature of the gear case at 70°C max.

Introduction  
0.36°/Geared  
C-Rev-  
AR  
AC Input Motor & Driver  
0.72°/Geared  
RK  
0.36°/Geared  
C-Rev-  
AR  
DC Input Motor & Driver  
0.36°/0.72°/  
Geared  
CRK  
DC Input Motor & Driver  
1.8°/Geared  
RRK  
0.9°/1.8°/Geared  
CMK  
0.72°  
PK  
1.8°/Geared  
High-Torque  
PKP  
Motor Only  
0.9°/1.8°/Geared  
PK  
Controllers  
SG8030JY  
Accessories

## Driver Specifications

	Built-In Controller Package	Pulse Input Package
Maximum Input Pulse Frequency	—	When the host controller is a line driver output: 500 kHz (When the pulse duty is 50%) When the host controller is an open-collector output: 250 kHz (When the pulse duty is 50%)*
Number of Positioning Data Sets	64 Points	—
Positioning Operation	One-Shot	○
	Linked	○
	Linked 2	○
	Sequential	○
	Direct	○
	Pushing	○
Continuous Operation	○	—
JOG Operation	○	—
Return-To-Home Operation	○	—
Test Operation	○	○
Control Module <b>OPX-2A</b>	○	○
Data Setting Software <b>MEXE02</b>	○	○

\*Value applies when an accessory general-purpose cable (**CC36D1-1**) is used.  
General-purpose cable → Page A-345

## Built-In Controller Package RS-485 Communication Specifications

Protocol	Modbus protocol (Modbus RTU mode)
Electrical Characteristics	EIA-485 compliance Twisted-pair wire (TIA/EIA-568B CAT5e or greater recommended) is used up to a total extension length of 50 m.
Transmission/Reception Mode	Half-duplex communication
Baud Rate	9600 bps/19200 bps/38400 bps/57600 bps/115200 bps
Physical Layer	Asynchronous mode (data: 8-bit, stop bit: 1-bit/2-bit, parity: none/odd/even)
Connection Type	Up to 31 units can be connected to one programmable controller (master equipment).

## General Specifications

	Motor	Driver	
		Built-In Controller Package	Pulse Input Package
Thermal Class	130 (B)	—	
Insulation Resistance	100 M $\Omega$ or more when 500 VDC megger is applied between the following places: • Case – Motor and sensor windings • Case – Electromagnetic brake windings	100 M $\Omega$ or more when 500 VDC megger is applied between the following places: • PE terminal – Power supply terminal • Signal I/O terminal – Power supply terminal	
Dielectric Strength	Sufficient to withstand the following for 1 minute: • Case – Motor and sensor windings 1.5 kVAC 50 Hz or 60 Hz • Case – Electromagnetic brake windings 1.5 kVAC 50 Hz or 60 Hz	Sufficient to withstand the following for 1 minute: • PE terminal – Power supply terminal 1.8 kVAC 50 Hz or 60 Hz • Signal I/O terminal – Power supply terminal 1.9 kVAC 50 Hz or 60 Hz • PE terminal – Power supply terminal 1.5 kVAC 50 Hz or 60 Hz • Signal I/O terminal – Power supply terminal 1.8 kVAC 50 Hz or 60 Hz	
Operating Environment (In Operation)	Ambient Temperature	–10~+50°C (non-freezing)*1: Standard type, <b>TH, PS, PN</b> geared type 0~+40°C (non-freezing)*1: Harmonic geared type	0~+55°C (non-freezing)*2
	Ambient Humidity	85% or less (non-condensing)	0~+50°C (non-freezing)*2
	Atmosphere	No corrosive gases, dust, water or oil	
Stop Position Accuracy	<b>AR46</b> : $\pm 4$ arc minutes ( $\pm 0.067^\circ$ ) <b>AR66, AR69, AR98, AR91 1</b> : $\pm 3$ arc minutes ( $\pm 0.05^\circ$ )		
Shaft Runout	0.05 T. I. R. (mm)*3	—	
Concentricity for Shaft in the Mounting Pilot	0.075 T. I. R. (mm)*3	—	
Perpendicularity for Shaft of the Mounting Surface	0.075 T. I. R. (mm)*3	—	

\*1 When a heat sink of a capacity at least equivalent to an aluminum plate with a size of 250×250 mm, 6 mm thick is installed.

\*2 When a heat sink of a capacity at least equivalent to an aluminum plate with a size of 200×200 mm, 2 mm thick is installed.

\*3 T. I. R. (Total Indicator Reading): The total dial gauge reading when the measurement section is rotated one revolution centered on the reference axis shaft center.

### Note

● Do not measure insulation resistance or perform the dielectric strength test while the motor and driver are connected.

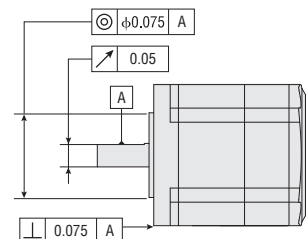

## Permissible Overhung Load and Permissible Thrust Load

→ Page A-14

## Load Torque – Driver Input Current Characteristics

This is the relationship between the load torque and driver input current at each speed when the motor is operated. From these characteristics, the current capacity required when used for multiple axes can be estimated. For geared motors, convert to torque and speed at the motor shaft.

$$\text{Motor shaft speed [r/min]} = \text{Gear output shaft speed} \times \text{Gear ratio}$$

$$\text{Motor shaft torque [N·m]} = \frac{\text{Gear output shaft torque}}{\text{Gear ratio}}$$

**AR46**□C

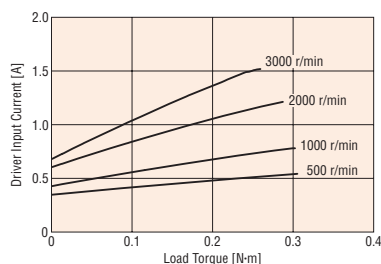

**AR66**□C

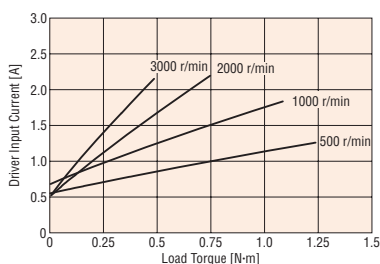

**AR69**□C

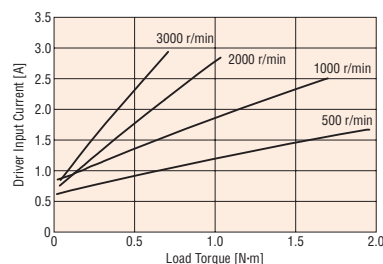

**AR98**□C

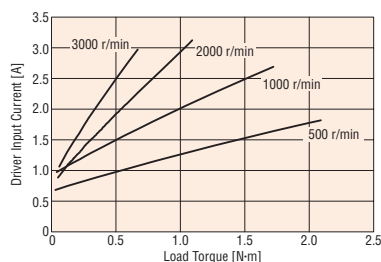

**AR911**□C

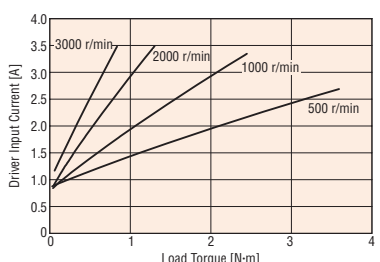

**Note**

- Either **A** (single shaft), **B** (double shaft) or **M** (electromagnetic brake) indicating the configuration is entered where the box □ is located within the product name.
- Either **A** (single shaft), **B** (double shaft) indicating the configuration is entered where the box □ is located within the product name of **AR911**.
- The built-in positioning function type has a low reference value of approximately 0.1 A.

## Dimensions (Unit = mm)

### ● Motors

#### ◇ Standard Type

Frame Size 42 mm

Product Name		Motor Product Name	Mass kg
Built-In Controller	Pulse Input		
AR46ACD-◇	AR46AC-◇	ARM46AC	0.47
AR46BCD-◇	AR46BC-◇	ARM46BC	

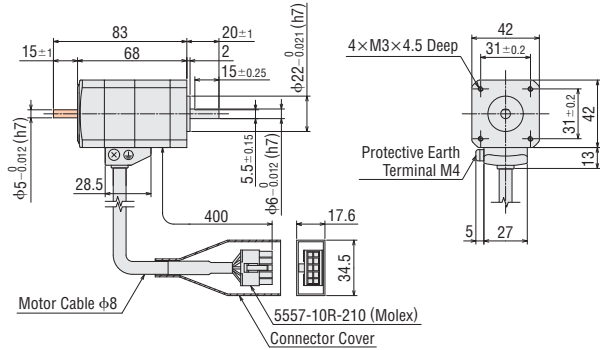

Frame Size 60 mm

Product Name		Motor Product Name	L1	L2	Mass kg
Built-In Controller	Pulse Input				
AR66ACD-◇	AR66AC-◇	ARM66AC	64.5	—	0.9
AR66BCD-◇	AR66BC-◇	ARM66BC		85.5	
AR69ACD-◇	AR69AC-◇	ARM69AC	90	—	1.4
AR69BCD-◇	AR69BC-◇	ARM69BC		111	

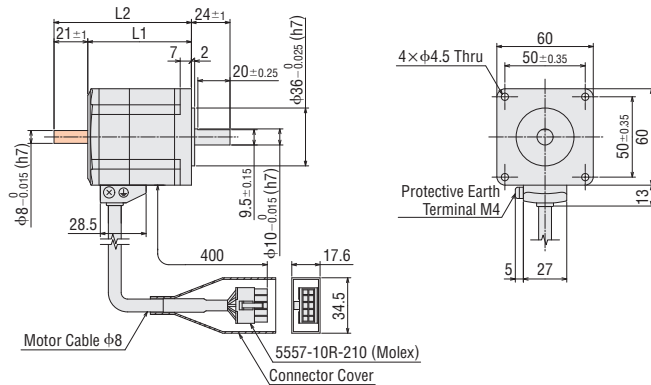

Frame Size 85 mm

Product Name		Motor Product Name	L1	L2	Mass kg
Built-In Controller	Pulse Input				
AR98ACD-◇	AR98AC-◇	ARM98AC	79.5	—	1.9
AR98BCD-◇	AR98BC-◇	ARM98BC		100.5	
AR911ACD-◇	AR911AC-◇	ARM911AC	109.5	—	3.0
AR911BCD-◇	AR911BC-◇	ARM911BC		130.5	

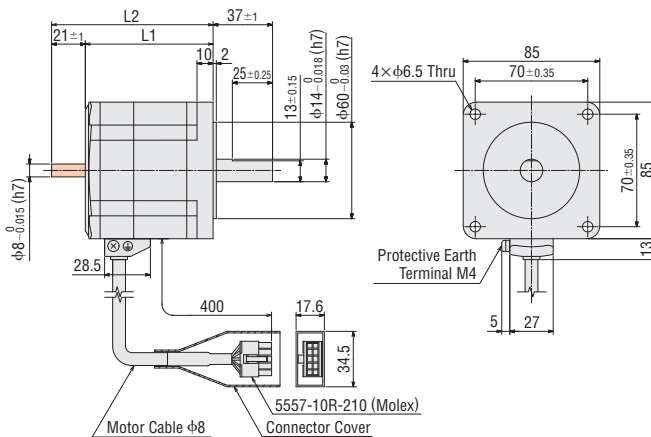

- A number indicating the desired length of **1** (1 m), **2** (2 m) or **3** (3 m) for the cable included with the product is entered where the box ◇ is located within the product name.
- These dimensions are for double shaft models. For single shaft models, ignore the  areas.

## ◇ Standard Type with Electromagnetic Brake

### Frame Size 42 mm

Product Name		Motor Product Name	Mass kg
Built-In Controller	Pulse Input		
<b>AR46MCD</b> -◇	<b>AR46MC</b> -◇	ARM46MC	0.62

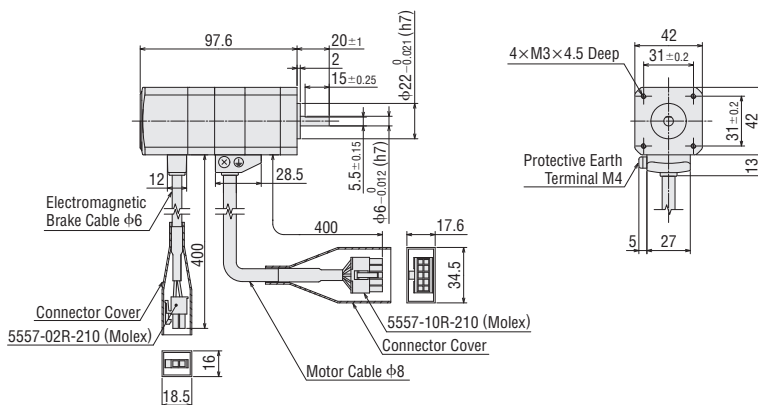

### Frame Size 60 mm

Product Name		Motor Product Name	L	Mass kg
Built-In Controller	Pulse Input			
<b>AR66MCD</b> -◇	<b>AR66MC</b> -◇	ARM66MC	99.5	1.2
<b>AR69MCD</b> -◇	<b>AR69MC</b> -◇	ARM69MC	125	1.7

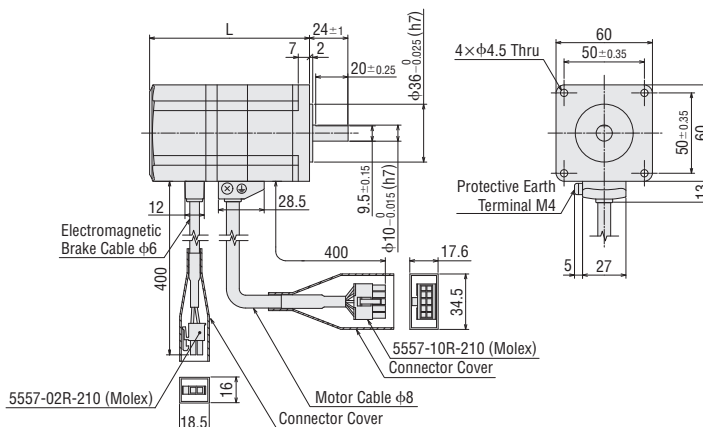

### Frame Size 85 mm

Product Name		Motor Product Name	Mass kg
Built-In Controller	Pulse Input		
<b>AR98MCD</b> -◇	<b>AR98MC</b> -◇	ARM98MC	2.5

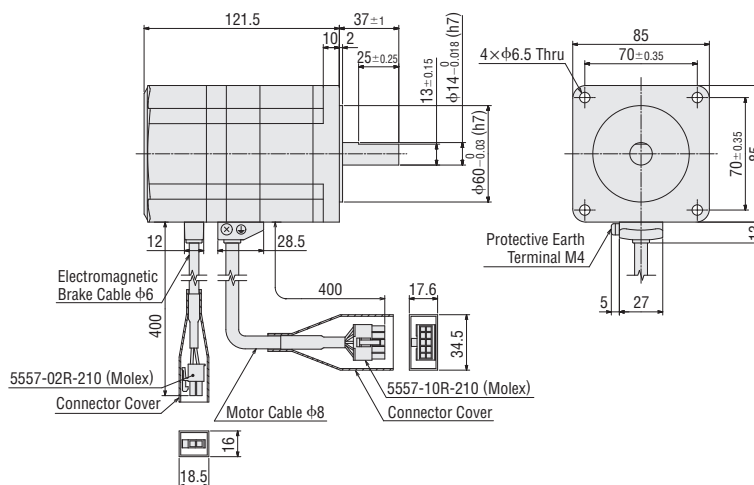

● A number indicating the desired length of **1** (1 m), **2** (2 m) or **3** (3 m) for the cable included with the product is entered where the box ◇ is located within the product name.

◇ TH Geared Type

Frame Size 42 mm

Product Name		Motor Product Name	Gear Ratio	Mass kg
Built-In Controller	Pulse Input			
AR46ACD-T $\square$ -◇	AR46AC-T $\square$ -◇	ARM46AC-T $\square$	<b>3.6, 7.2, 10, 20, 30</b>	0.62

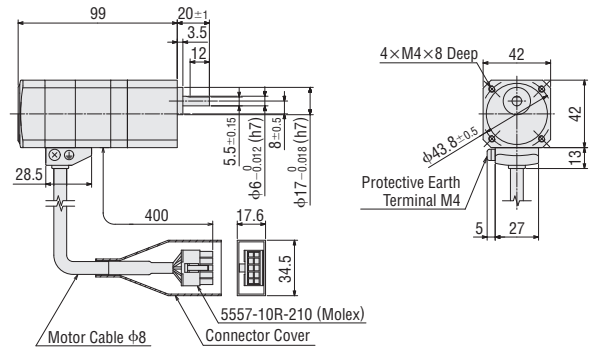

Frame Size 60 mm

Product Name		Motor Product Name	Gear Ratio	Mass kg
Built-In Controller	Pulse Input			
AR66ACD-T $\square$ -◇	AR66AC-T $\square$ -◇	ARM66AC-T $\square$	<b>3.6, 7.2, 10, 20, 30</b>	1.3

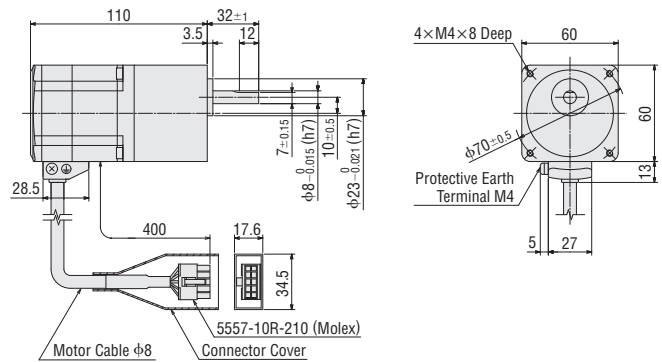

Frame Size 90 mm

Product Name		Motor Product Name	Gear Ratio	Mass kg
Built-In Controller	Pulse Input			
AR98ACD-T $\square$ -◇	AR98AC-T $\square$ -◇	ARM98AC-T $\square$	<b>3.6, 7.2, 10, 20, 30</b>	3.1

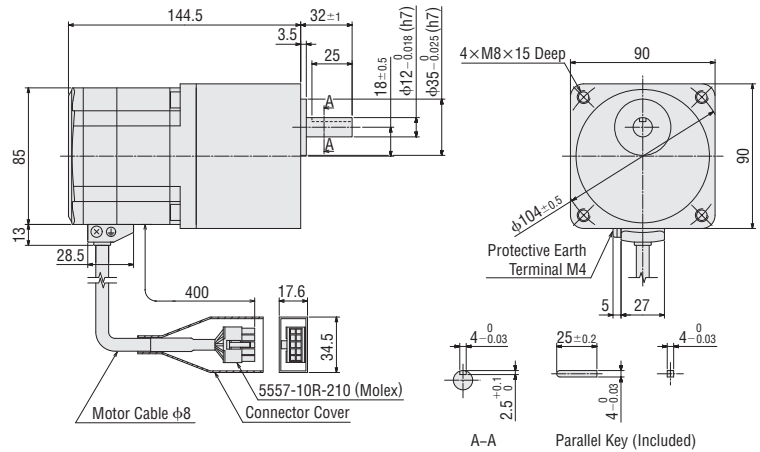

● A number indicating the gear ratio is entered where the box  $\square$  is located within the product name.

A number indicating the desired length of 1 (1 m), 2 (2 m) or 3 (3 m) for the cable included with the product is entered where the box ◇ is located within the product name.

## ◇ TH Geared Type with Electromagnetic Brake

### Frame Size 42 mm

Product Name		Motor Product Name	Gear Ratio	Mass kg
Built-In Controller	Pulse Input			
AR46MCD-T- <span style="border: 1px solid black; display: inline-block; width: 10px; height: 10px;"></span> ◇	AR46MC-T- <span style="border: 1px solid black; display: inline-block; width: 10px; height: 10px;"></span> ◇	ARM46MC-T <span style="border: 1px solid black; display: inline-block; width: 10px; height: 10px;"></span>	<b>3.6, 7.2, 10, 20, 30</b>	0.77

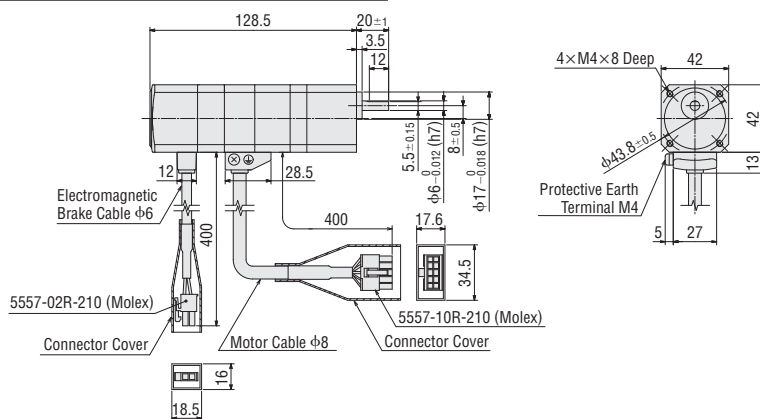

### Frame Size 60 mm

Product Name		Motor Product Name	Gear Ratio	Mass kg
Built-In Controller	Pulse Input			
AR66MCD-T- <span style="border: 1px solid black; display: inline-block; width: 10px; height: 10px;"></span> ◇	AR66MC-T- <span style="border: 1px solid black; display: inline-block; width: 10px; height: 10px;"></span> ◇	ARM66MC-T <span style="border: 1px solid black; display: inline-block; width: 10px; height: 10px;"></span>	<b>3.6, 7.2, 10, 20, 30</b>	1.6

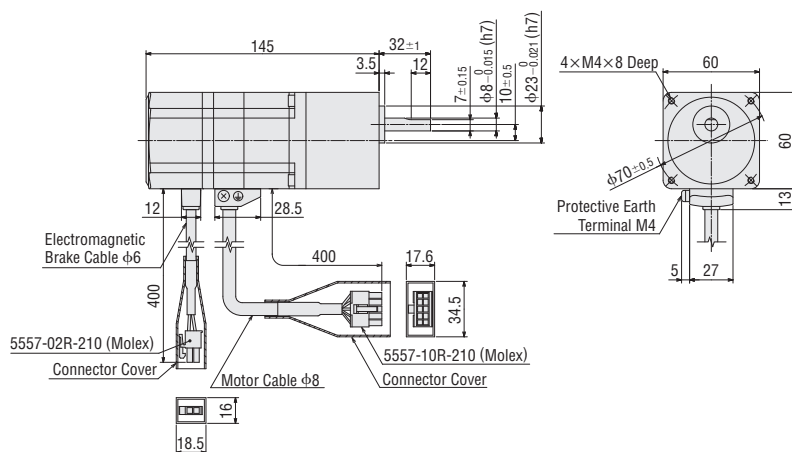

### Frame Size 90 mm

Product Name		Motor Product Name	Gear Ratio	Mass kg
Built-In Controller	Pulse Input			
AR98MCD-T- <span style="border: 1px solid black; display: inline-block; width: 10px; height: 10px;"></span> ◇	AR98MC-T- <span style="border: 1px solid black; display: inline-block; width: 10px; height: 10px;"></span> ◇	ARM98MC-T <span style="border: 1px solid black; display: inline-block; width: 10px; height: 10px;"></span>	<b>3.6, 7.2, 10, 20, 30</b>	3.7

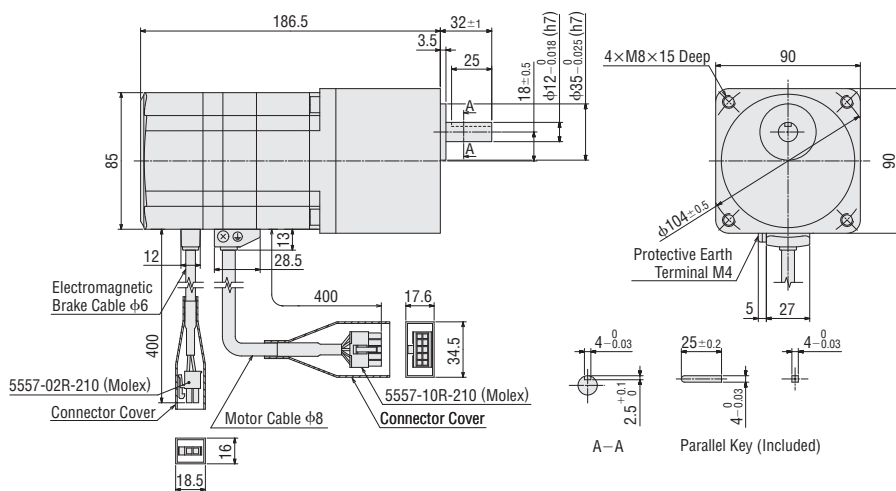

● A number indicating the gear ratio is entered where the box  is located within the product name.

A number indicating the desired length of **1** (1 m), **2** (2 m) or **3** (3 m) for the cable included with the product is entered where the box  is located within the product name.

◇ PS Geared Type

Frame Size 42 mm

Product Name		Motor Product Name	Gear Ratio	L	Mass kg
Built-In Controller	Pulse Input				
AR46ACD-PS■-◇	AR46AC-PS■-◇	ARM46AC-PS■	5, 7.2, 10	96	0.67
			25, 36, 50	119.5	0.82

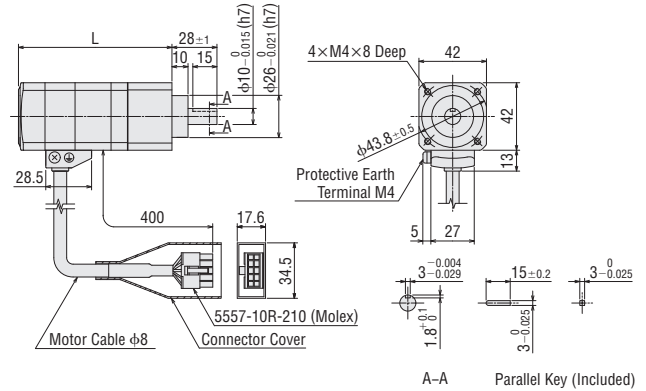

Frame Size 60 mm

Product Name		Motor Product Name	Gear Ratio	L	Mass kg
Built-In Controller	Pulse Input				
AR66ACD-PS■-◇	AR66AC-PS■-◇	ARM66AC-PS■	5, 7.2, 10	97	1.3
			25, 36, 50	117	1.6

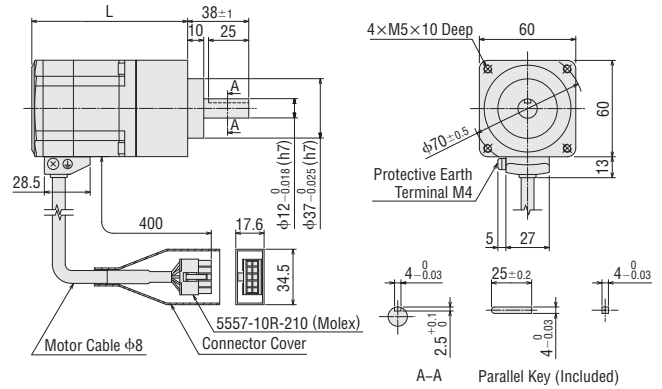

Frame Size 90 mm

Product Name		Motor Product Name	Gear Ratio	L	Mass kg
Built-In Controller	Pulse Input				
AR98ACD-PS■-◇	AR98AC-PS■-◇	ARM98AC-PS■	5, 7.2, 10	127	3.3
			25, 36, 50	154.5	4.1

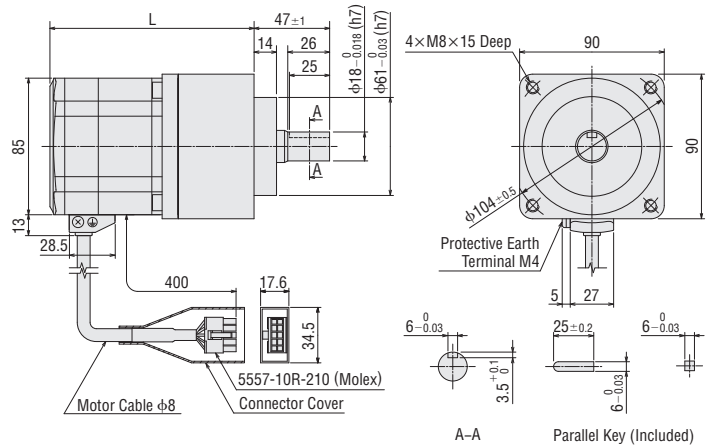

● A number indicating the gear ratio is entered where the box ■ is located within the product name.

A number indicating the desired length of 1 (1 m), 2 (2 m) or 3 (3 m) for the cable included with the product is entered where the box ◇ is located within the product name.



## ◇ PS Geared Type with Electromagnetic Brake

### Frame Size 42 mm

Product Name		Motor Product Name	Gear Ratio	L	Mass kg
Built-In Controller	Pulse Input				
<b>AR46MCD-PS</b> ■-◇	<b>AR46MC-PS</b> ■-◇	ARM46MC-PS■	<b>5, 7, 2, 10</b>	125.5	0.82
			<b>25, 36, 50</b>	149	0.97

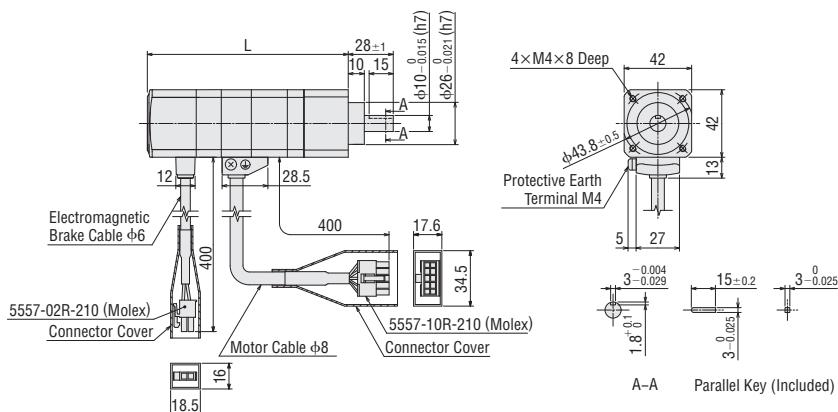

### Frame Size 60 mm

Product Name		Motor Product Name	Gear Ratio	L	Mass kg
Built-In Controller	Pulse Input				
<b>AR66MCD-PS</b> ■-◇	<b>AR66MC-PS</b> ■-◇	ARM66MC-PS■	<b>5, 7, 2, 10</b>	132	1.6
			<b>25, 36, 50</b>	152	1.9

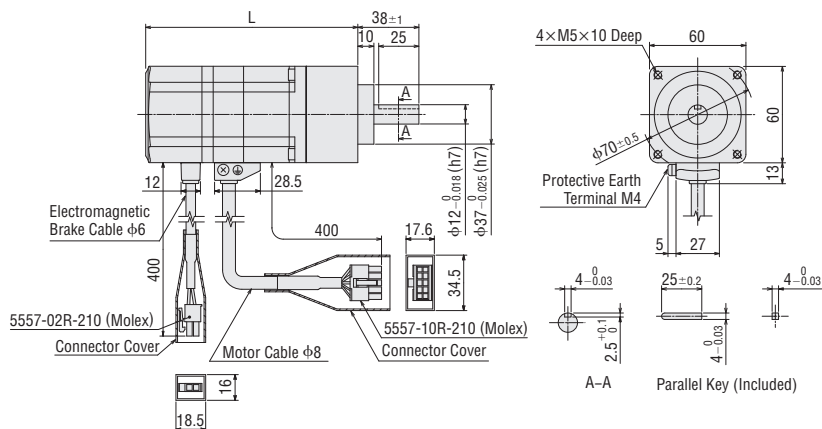

### Frame Size 90 mm

Product Name		Motor Product Name	Gear Ratio	L	Mass kg
Built-In Controller	Pulse Input				
<b>AR98MCD-PS</b> ■-◇	<b>AR98MC-PS</b> ■-◇	ARM98MC-PS■	<b>5, 7, 2, 10</b>	169	3.9
			<b>25, 36, 50</b>	196.5	4.7

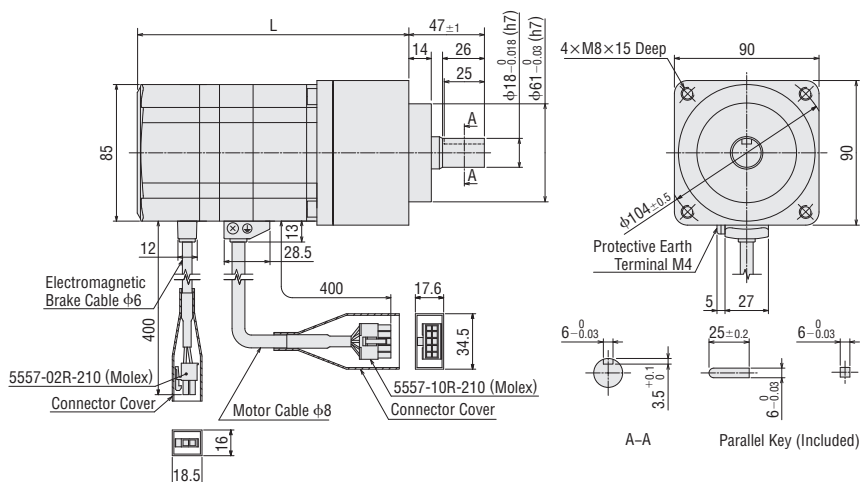

● A number indicating the gear ratio is entered where the box ■ is located within the product name.

A number indicating the desired length of 1 (1 m), 2 (2 m) or 3 (3 m) for the cable included with the product is entered where the box ◇ is located within the product name.

◇ PN Geared Type

Frame Size 42 mm

Product Name		Motor Product Name	Gear Ratio	Mass kg
Built-In Controller	Pulse Input			
AR46ACD-N-◇	AR46AC-N-◇	ARM46AC-N■	<b>5, 7.2, 10</b>	0.73

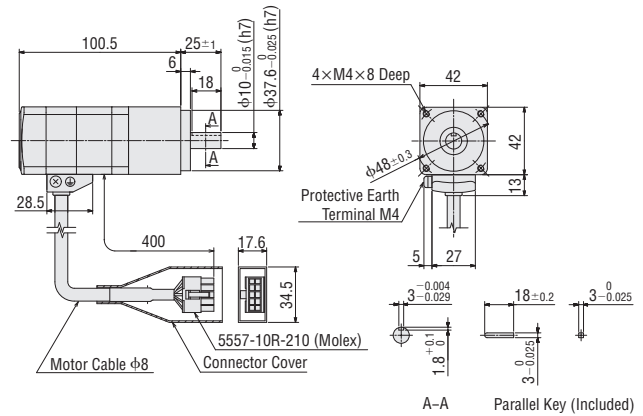

Frame Size 60 mm

Product Name		Motor Product Name	Gear Ratio	L	Mass kg
Built-In Controller	Pulse Input				
AR66ACD-N-◇	AR66AC-N-◇	ARM66AC-N■	<b>5, 7.2, 10</b>	109	1.5
			<b>25, 36, 50</b>	125	1.73

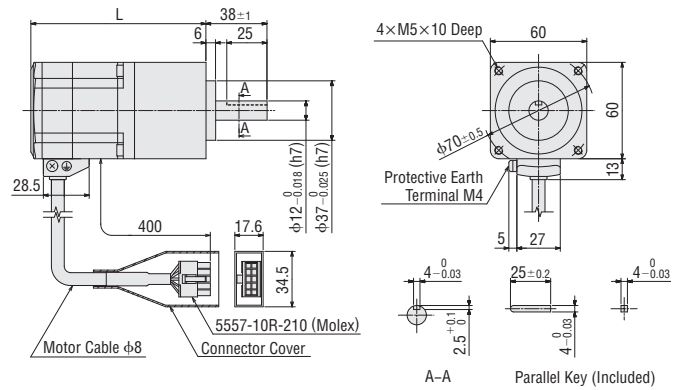

Frame Size 90 mm

Product Name		Motor Product Name	Gear Ratio	L	Mass kg
Built-In Controller	Pulse Input				
AR98ACD-N-◇	AR98AC-N-◇	ARM98AC-N■	<b>5, 7.2, 10</b>	140	3.8
			<b>25, 36, 50</b>	163	4.5

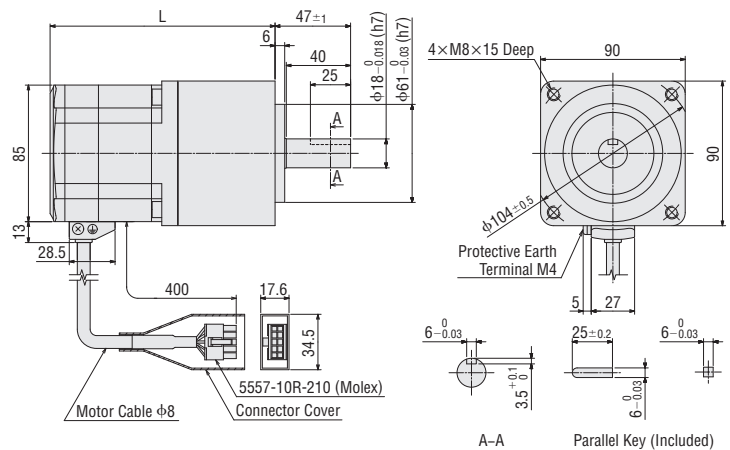

● A number indicating the gear ratio is entered where the box ■ is located within the product name.

A number indicating the desired length of 1 (1 m), 2 (2 m) or 3 (3 m) for the cable included with the product is entered where the box ◇ is located within the product name.

## ◇ PN Geared Type with Electromagnetic Brake

Frame Size 42 mm

Product Name		Motor Product Name	Gear Ratio	Mass kg
Built-In Controller	Pulse Input			
<b>AR46MCD-N</b> ■◇	<b>AR46MC-N</b> ■◇	ARM46MC-N■	<b>5, 7.2, 10</b>	0.88

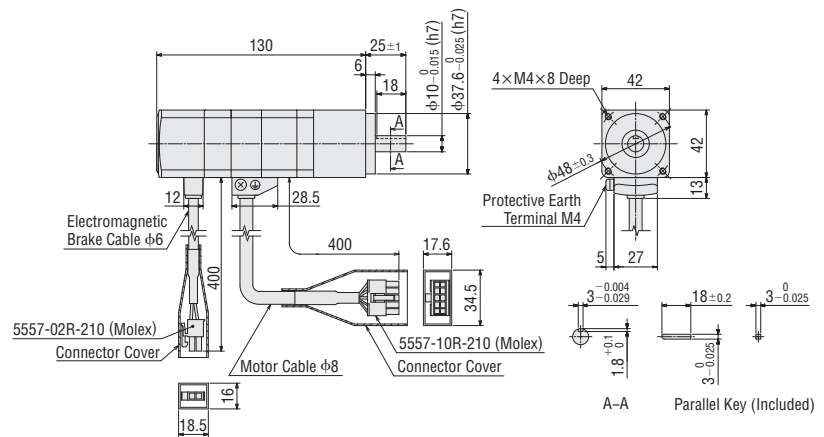

Frame Size 60 mm

Product Name		Motor Product Name	Gear Ratio	L	Mass kg
Built-In Controller	Pulse Input				
<b>AR66MCD-N</b> ■◇	<b>AR66MC-N</b> ■◇	ARM66MC-N■	<b>5, 7.2, 10</b>	144	1.8
			<b>25, 36, 50</b>	160	2

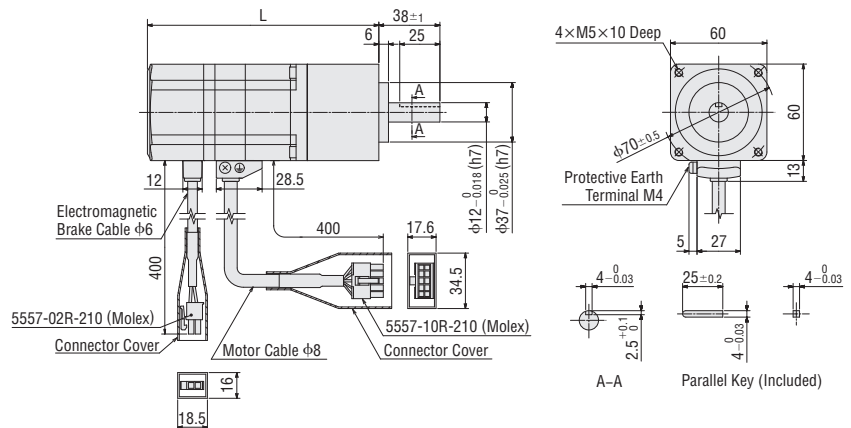

Frame Size 90 mm

Product Name		Motor Product Name	Gear Ratio	L	Mass kg
Built-In Controller	Pulse Input				
<b>AR98MCD-N</b> ■◇	<b>AR98MC-N</b> ■◇	ARM98MC-N■	<b>5, 7.2, 10</b>	182	4.4
			<b>25, 36, 50</b>	205	5.1

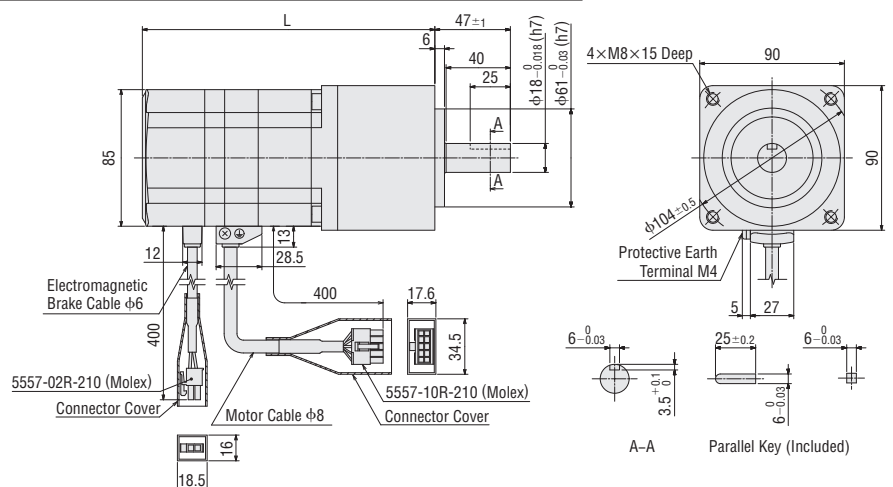

● A number indicating the gear ratio is entered where the box ■ is located within the product name.

A number indicating the desired length of 1 (1 m), 2 (2 m) or 3 (3 m) for the cable included with the product is entered where the box ◇ is located within the product name.

◇ Harmonic Geared Type

Frame Size 42 mm

Product Name		Motor Product Name	Gear Ratio	Mass kg
Built-In Controller	Pulse Input			
AR46ACD-H- <span style="border: 1px solid black; display: inline-block; width: 10px; height: 10px;"></span> ◇	AR46AC-H- <span style="border: 1px solid black; display: inline-block; width: 10px; height: 10px;"></span> ◇	ARM46AC-H <span style="border: 1px solid black; display: inline-block; width: 10px; height: 10px;"></span>	<b>50, 100</b>	0.68

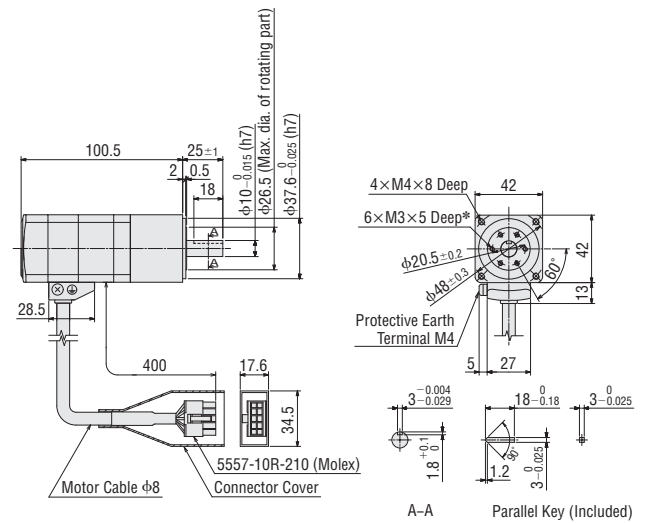

\* The position of the output shaft relative to the screw holes on the rotating part is arbitrary.

Frame Size 60 mm

Product Name		Motor Product Name	Gear Ratio	Mass kg
Built-In Controller	Pulse Input			
AR66ACD-H- <span style="border: 1px solid black; display: inline-block; width: 10px; height: 10px;"></span> ◇	AR66AC-H- <span style="border: 1px solid black; display: inline-block; width: 10px; height: 10px;"></span> ◇	ARM66AC-H <span style="border: 1px solid black; display: inline-block; width: 10px; height: 10px;"></span>	<b>50, 100</b>	1.41

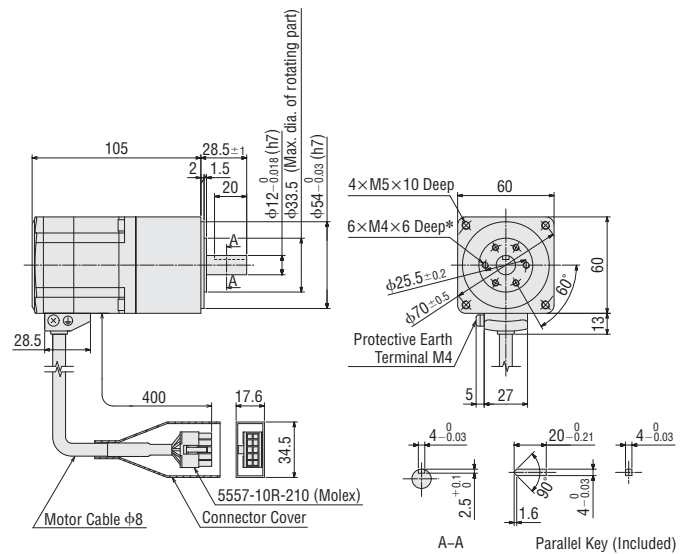

\* The position of the output shaft relative to the screw holes on the rotating part is arbitrary.

● A number indicating the gear ratio is entered where the box  is located within the product name.

A number indicating the desired length of **1** (1 m), **2** (2 m) or **3** (3 m) for the cable included with the product is entered where the box  is located within the product name.

## Frame Size 90 mm

Product Name		Motor Product Name	Gear Ratio	Mass kg
Built-In Controller	Pulse Input			
<b>AR98ACD-H</b> ■◇	<b>AR98AC-H</b> ■◇	ARM98AC-H■	<b>50, 100</b>	4

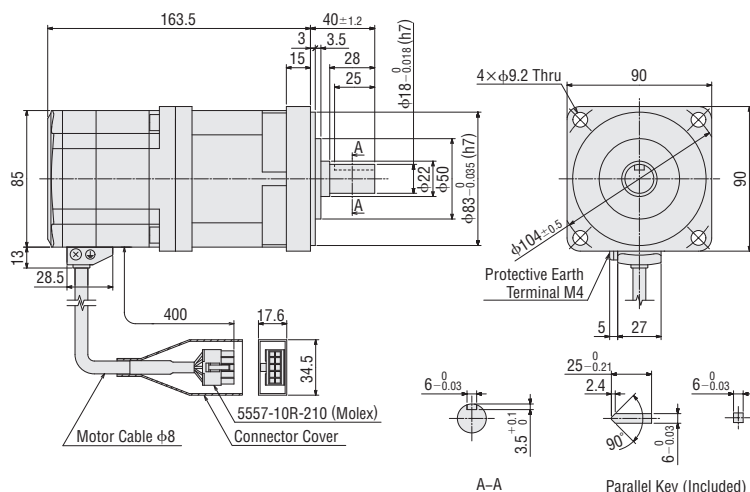

## ◇ Harmonic Geared Type with Electromagnetic Brake

### Frame Size 42 mm

Product Name		Motor Product Name	Gear Ratio	Mass kg
Built-In Controller	Pulse Input			
<b>AR46MCD-H</b> ■◇	<b>AR46MC-H</b> ■◇	ARM46MC-H■	<b>50, 100</b>	0.83

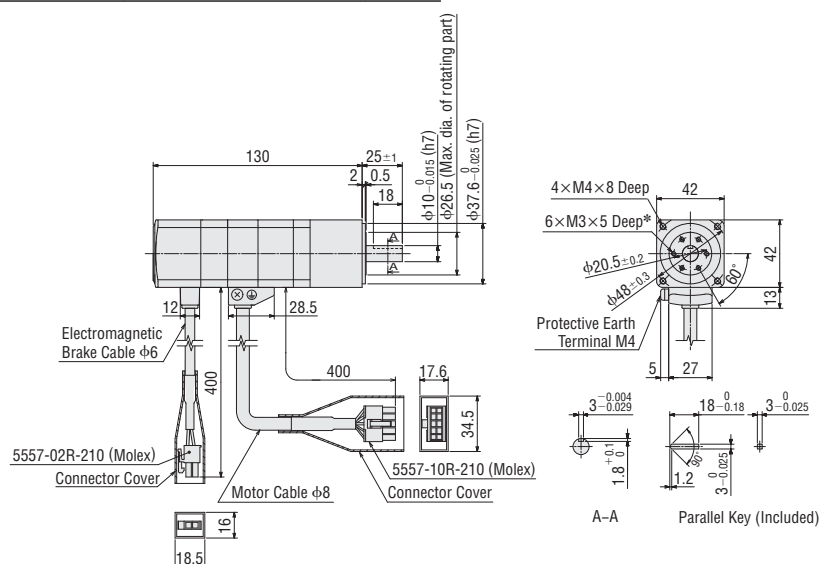

\* The position of the output shaft relative to the screw holes on the rotating part is arbitrary.

● A number indicating the gear ratio is entered where the box ■ is located within the product name.

A number indicating the desired length of **1** (1 m), **2** (2 m) or **3** (3 m) for the cable included with the product is entered where the box ◇ is located within the product name.

Frame Size 60 mm

Product Name		Motor Product Name	Gear Ratio	Mass kg
Built-In Controller	Pulse Input			
AR66MCD-H $\square$ $\diamond$	AR66MC-H $\square$ $\diamond$	ARM66MC-H $\square$	<b>50, 100</b>	1.71

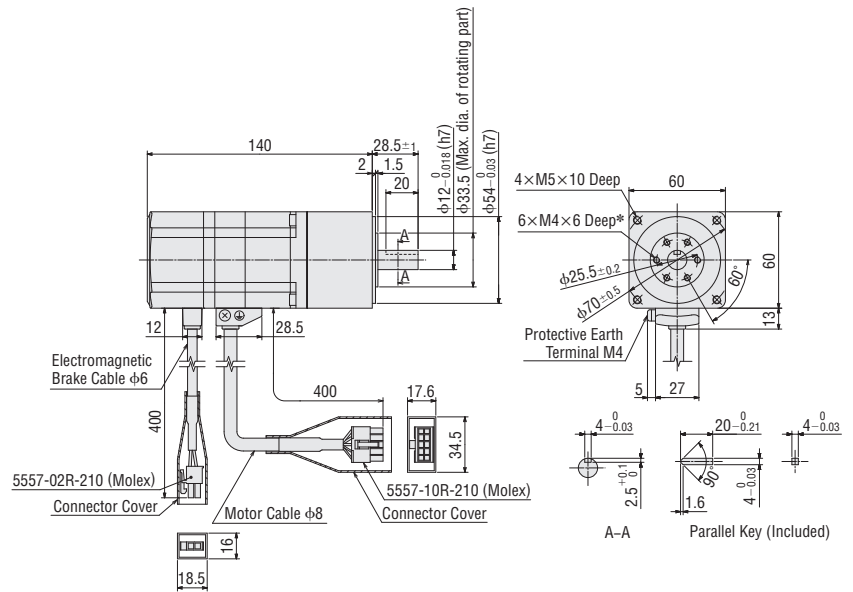

\* The position of the output shaft relative to the screw holes on the rotating part is arbitrary.

Frame Size 90 mm

Product Name		Motor Product Name	Gear Ratio	Mass kg
Built-In Controller	Pulse Input			
AR98MCD-H $\square$ $\diamond$	AR98MC-H $\square$ $\diamond$	ARM98MC-H $\square$	<b>50, 100</b>	4.6

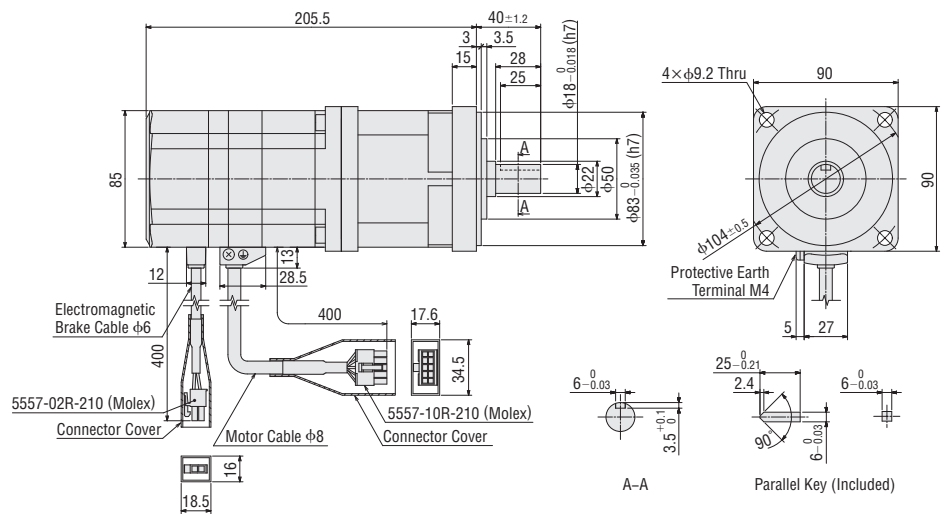

● A number indicating the gear ratio is entered where the box  $\square$  is located within the product name.

A number indicating the desired length of 1 (1 m), 2 (2 m) or 3 (3 m) for the cable included with the product is entered where the box  $\diamond$  is located within the product name.

● Cable for Motor (Included), Cable for Electromagnetic Brake (Included)

Common to All Types

● Cable for Motor

Cable Type	Length L (m)
Cable for Motor 1 m	1
Cable for Motor 2 m	2
Cable for Motor 3 m	3

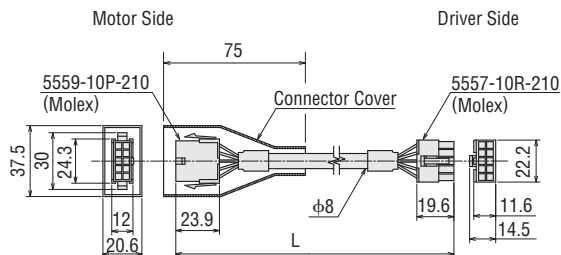

● Cable for Electromagnetic Brake  
(Only for electromagnetic brake type)

Cable Type	Length L (m)
Cable for Motor 1 m	1
Cable for Motor 2 m	2
Cable for Motor 3 m	3

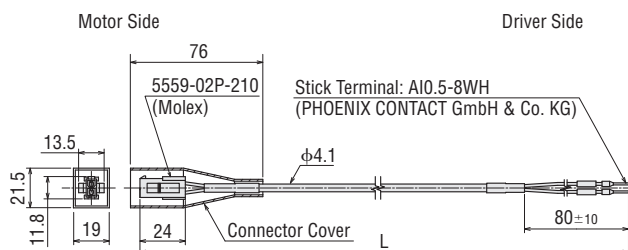

● Drivers

◇ Built-In Controller Package

Mass: 0.75 kg

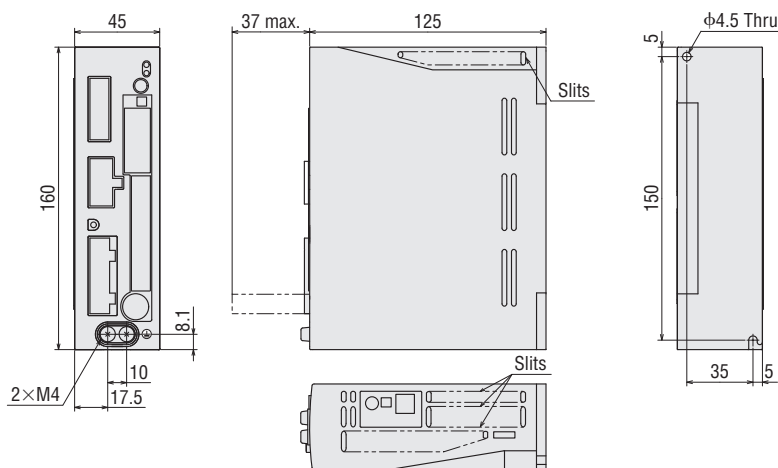

● Accessories

- Connector for Power Input Terminal (CN1)  
Connector: MC1,5/6-STF-3,5 (PHOENIX CONTACT GmbH & Co. KG)
- Connector for Sensor Signal (CN5)  
Connector: FK-MC0,5/5-ST-2,5 (PHOENIX CONTACT GmbH & Co. KG)
- Connector for Input Signal (CN8)  
Connector: FK-MC0,5/9-ST-2,5 (PHOENIX CONTACT GmbH & Co. KG)
- Connector for Output Signal (CN9)  
Connector: FK-MC0,5/7-ST-2,5 (PHOENIX CONTACT GmbH & Co. KG)
- Connector for Regeneration Unit/Main Power Supply (CN3)  
Connector: 54928-0570 (Molex)

◇ Pulse Input Package

Mass: 0.75 kg

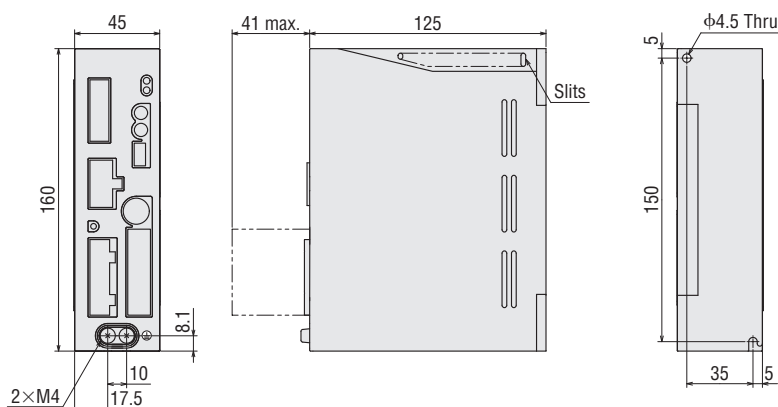

● Accessories

- Connector for Control I/O (CN5)  
Cover Assembly: 10336-52A0-008 (Sumitomo 3M Limited)  
Connector: 10136-3000PE (Sumitomo 3M Limited)
- Connector for Regeneration Unit Input/Main Power Supply Input Terminal (CN3)  
Connector: 54928-0570 (Molex)
- Connector for 24 VDC Power Supply Input/Regeneration Unit Thermal Input/Electromagnetic Brake Output Terminal (CN1)  
Connector: MC1,5/6-STF-3,5 (PHOENIX CONTACT GmbH & Co. KG)

## Connection and Operation (Built-In Controller Package)

### Names and Functions of Driver Parts

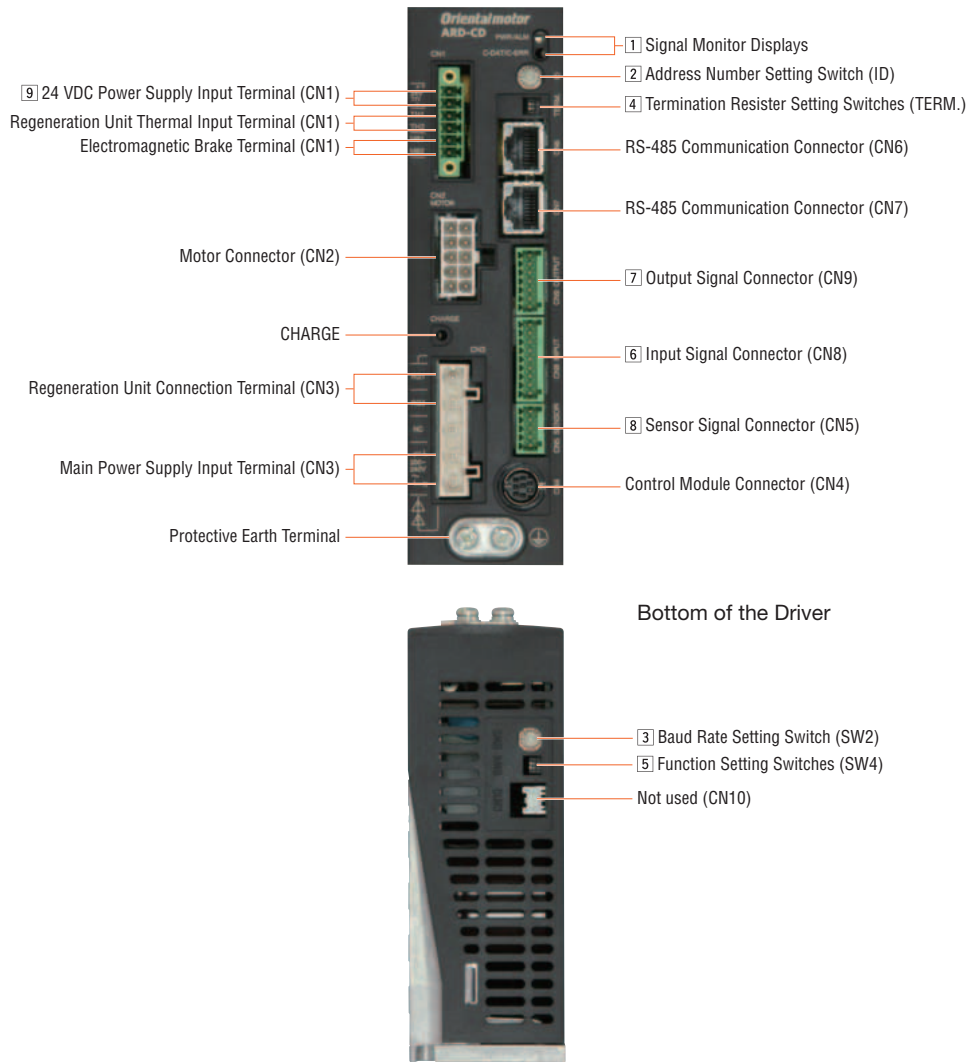

#### 1 Signal Monitor Displays

##### ◇ LED Indicators

Indication	Color	Function	When Activated
PWR	Green	Power Supply Indication	Lights when 24 VDC power is on.
ALM	Red	Alarm Indication	Blinks when protective functions are activated.
C-DAT	Green	Communication Indication	Blinks or illuminate when communication data is received or sent.
C-ERR	Red	Communication Error Indication	Illuminates when there is an error with communication data.

#### 2 Address Number Setting Switch (ID)

Indication	Switch Name	Function
ID	Address Number Setting Switch	Set the address number for RS-485 communication (Factory Setting: 0).

#### 3 Baud Rate Setting Switch (SW2)

Indication	Switch Name	Function
SW2	Baud Rate Setting Switch	Set the baud rate for RS-485 communications (Factory Setting: 7).

##### ◇ Setting the Baud Rate for RS-484 Communications

No.	Baud Rate (bps)
0	9600
1	19200
2	38400
3	57600
4	115200
5~6	Not used
7	Factory setting
8~F	Not used



## 4 Termination Resister Setting Switches (TERM.)

Indication	No.	Function
TERM.	1	Set the termination resister (120 Ω) for RS-485 communication (Factory setting: OFF).
	2	OFF: No termination resister ON: Set the termination resister

\*Please use the same settings for both No. 1 and No. 2.

## 5 Function Setting Switches (SW4)

Indication	No.	Function
SW4	1	This sets the address number in combination with the address number setting switch (ID) (Factory setting: OFF).
	2	This sets the protocol for RS-485 communication (Factory setting: OFF).

## ◇ RS-485 Communication Protocol Setting

Destination		Modbus RTU Mode
No. 2	OFF	ON

## 6 Input Signal Connector (CN8)

Indication	Pin No.	Signal Name	Initial Value
CN8	1	INO	HOME This performs the return-to-home operation.
	2	IN1	START This performs the positioning operation.
	3	IN2	M0
	4	IN3	M1 The operating data number is selected using 3 bits.
	5	IN4	M2
	6	IN5	FREE Stop motor excitation and release the electromagnetic brake.
	7	IN6	STOP This stops the motor.
	8	IN7	ALM-RST This resets the current alarm.

\*Assigned functions are set by means of the parameter settings. The above is the initial value. For details, refer to the User's Manual.

The following input signals can be assigned to input terminals IN0~7.

Input Signal								
0: Not used	5: SSTART	10: MS2	17: C-ON	27: HMI	36: R4	41: R9	46: R14	51: M3
1: FWD	6: +JOG	11: MS3	18: STOP	32: R0	37: R5	42: R10	47: R15	52: M4
2: RVS	7: -JOG	12: MS4	24: ALM-RST	33: R1	38: R6	43: R11	48: M0	53: M5
3: HOME	8: MS0	13: MS5	25: P-PRESET	34: R2	39: R7	44: R12	49: M1	
4: START	9: MS1	16: FREE	26: P-CLR	35: R3	40: R8	45: R13	50: M2	

## 7 Output Signal Connector (CN9)

Indication	Pin No.	Signal Name	Initial Value
CN9	1	OUT0	HOME-P Output when the motor is home.
	2	OUT1	END Output when the positioning operation has finished.
	3	OUT2	AREA1 Output when the motor is in area 1.
	4	OUT3	READY Output when driver operation preparations have finished.
	5	OUT4	WNG The driver's warning status is output.
	6	OUT5	ALM The driver's alarm status is output (normally closed).

\* Assigned functions are set by means of the parameter settings. The above is the initial value. For details, refer to the User's Manual.

The following output signals can be assigned to output terminals OUT0~5.

Output Signal									
0: Not used	7: -JOG_R	16: FREE_R	36: R4	43: R11	50: M2_R	63: SLIT_R	71: TLC		
1: FWD_R	8: MS0_R	17: C-ON_R	37: R5	44: R12	51: M3_R	65: ALM	72: TIM		
2: RVS_R	9: MS1_R	18: STOP_R	38: R6	45: R13	52: M4_R	66: WNG	73: AREA1		
3: HOME_R	10: MS2_R	32: R0	39: R7	46: R14	53: M5_R	67: READY	74: AREA2		
4: START_R	11: MS3_R	33: R1	40: R8	47: R15	60: +LS_R	68: MOVE	75: AREA3		
5: SSTART_R	12: MS4_R	34: R2	41: R9	48: M0_R	61: -LS_R	69: END	80: S-BSY		
6: +JOG_R	13: MS5_R	35: R3	42: R10	49: M1_R	62: HOMES_R	70: HOME-P	82: MPS		

## 8 Sensor Signal Connector (CN5)

Indication	Pin No.	Signal Name	Initial Value
CN5	1	+LS	+Side Limit Sensor Input
	2	-LS	-Side Limit Sensor Input
	3	HOMES	Mechanical Home Sensor Input
	4	SLIT	Slit Sensor Input
	5	IN-COM2	Common for Sensor

## 9 24 VDC Input/Regeneration Unit Thermal Input/Electromagnetic Brake Connction Terminal (CN1)

Indication	I/O	Terminal Name	Content
24V+	Input	24 VDC Power Input Terminal+	This is the power supply for the driver's control circuit terminal. Always connect when using.
24V-		24 VDC Power Input Terminal-	
TH1		Regeneration Unit Thermal Input Terminal	
TH2		Regeneration Unit Thermal Input Terminal	
MB1	Output	Electromagnetic Brake Connection Terminal-	This connects the electromagnetic brake line of an electromagnetic brake type motor.
MB2		Electromagnetic Brake Connection Terminal+	

● Connection Diagram

◇ Connection to Peripheral Equipment

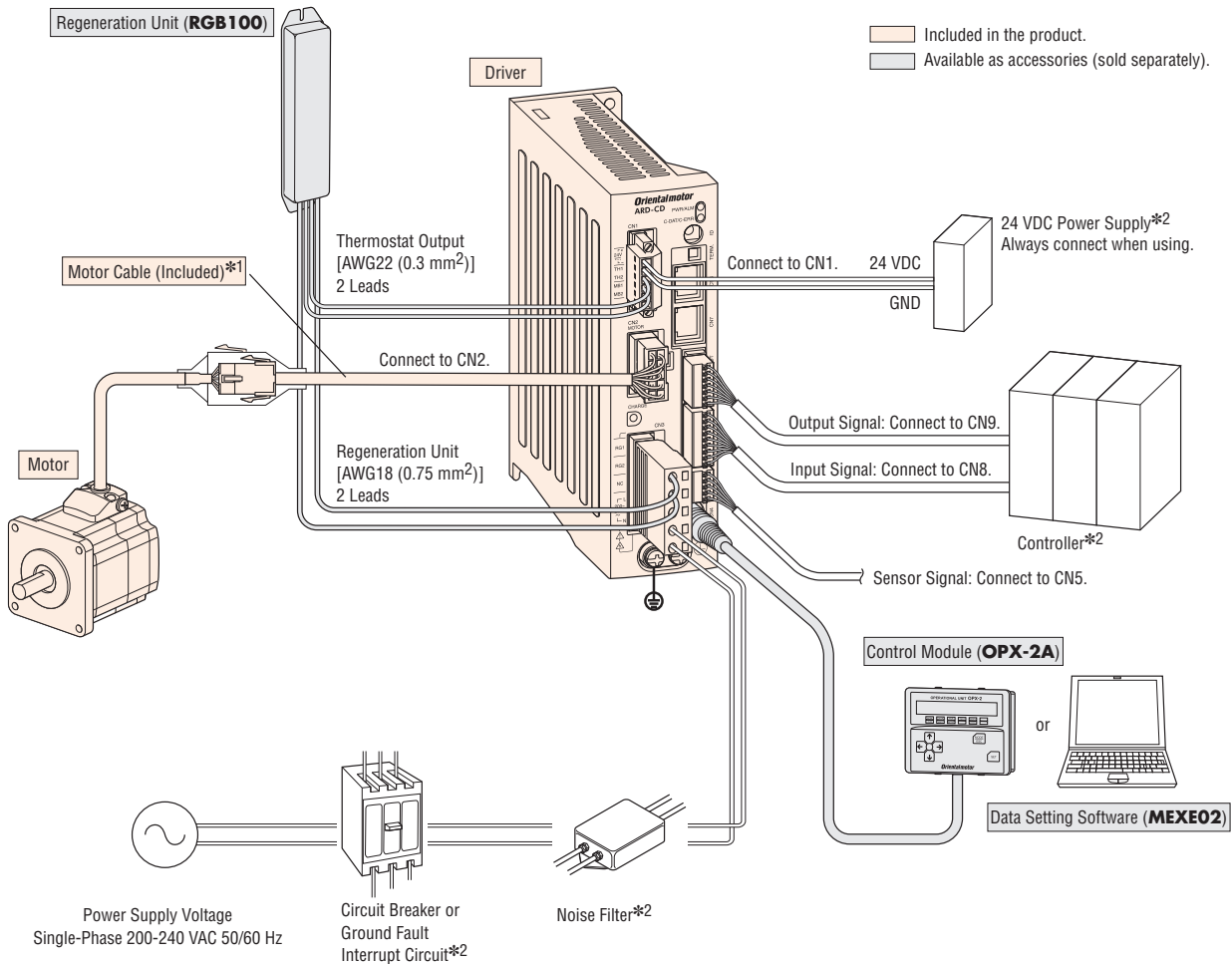

\*1 Each model comes with a motor cable 1, 2 or 3 m long. If you need a cable of a different length or a flexible cable, select an appropriate cable from among the accessories (sold separately). Keep the wiring distance between the motor and driver to 30 m max.  
 \*2 Not supplied.

◇ Connecting a Main Power Supply

Use the following cable for the power supply line;  
 3-core cable of AWG16 to 14 (1.25 to 2.0 mm<sup>2</sup>)

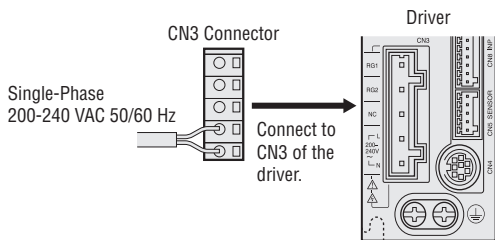

◇ Connecting the Control Power Supply

Provide a 24 VDC power supply.

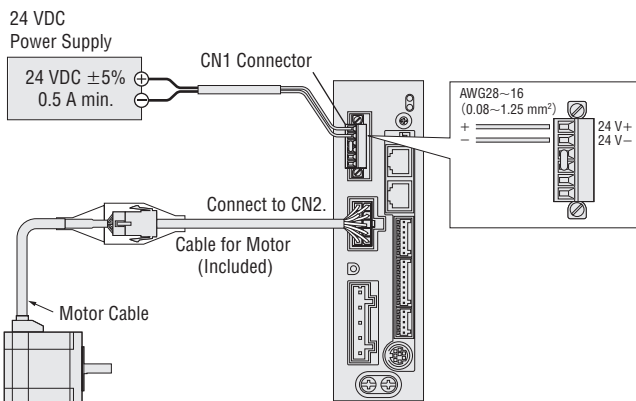

◇ Connecting the Electromagnetic Brake

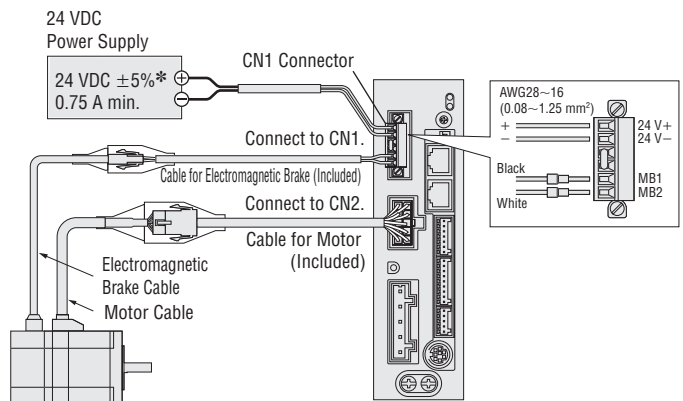

\*If the distance between the motor and driver is extended to 20 m or longer, use a power supply of 24 VDC ±4%.

## ◇ Connecting to a Host Controller

### ● Connecting to a Current Source Output Circuit

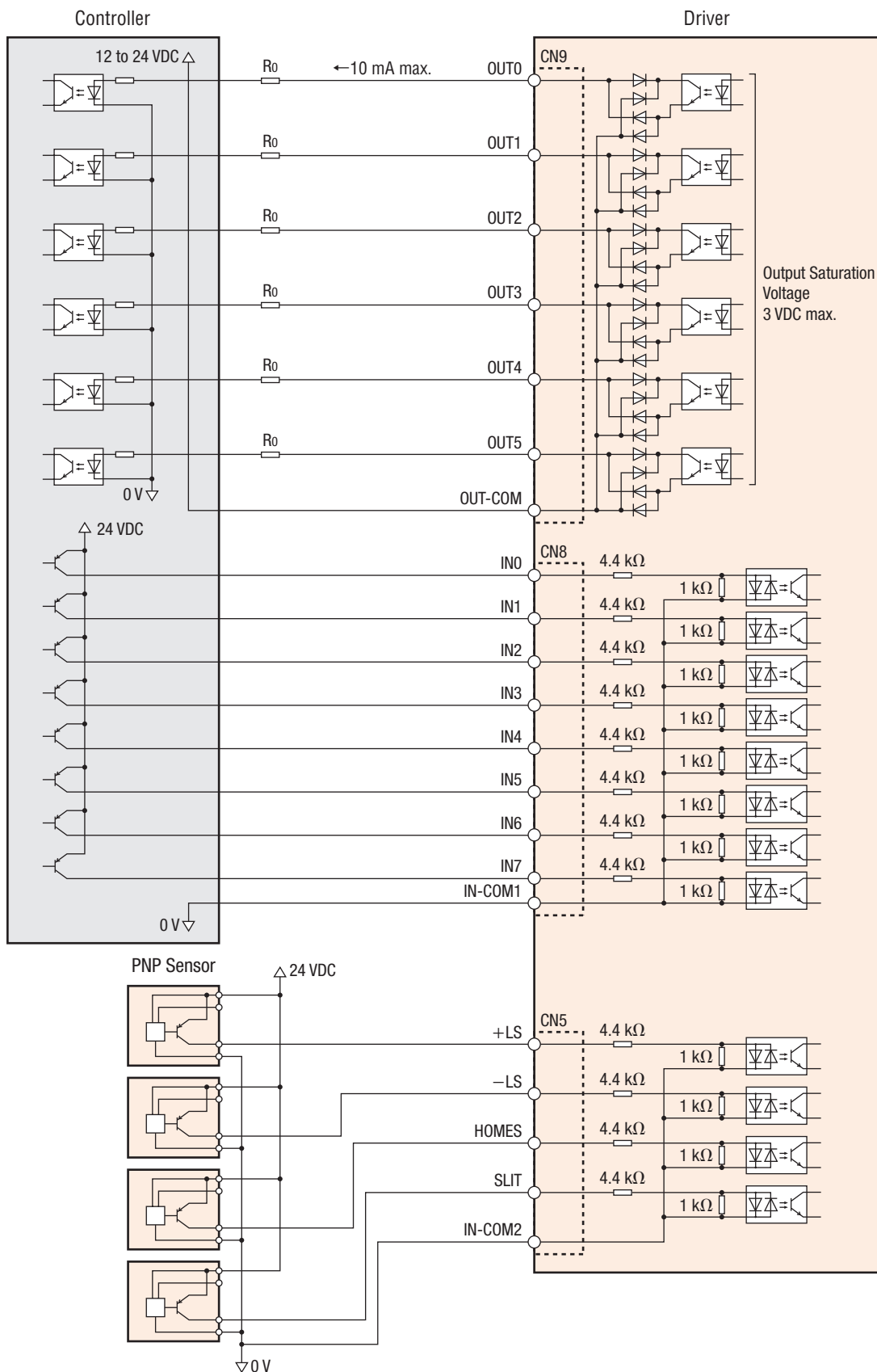

#### Note

- Use input signals at 24 VDC.
- Use output signals at 24 VDC or less. If the current exceeds 10 mA, connect an external resistor  $R_0$ .
- The saturation voltage of the output signal is 3 VDC max.
- Provide a minimum distance of 200 mm between the signal lines and power lines (AC lines, motor lines).  
Do not run the signal lines in the same duct as power lines nor bundle them with power lines.
- If noise generated by the motor cable or power supply cable causes a problem with the specific wiring or layout, shield the cable or use ferrite cores.

◇ Connecting to a Host Controller

● Connecting to a Current Sink Output Circuit

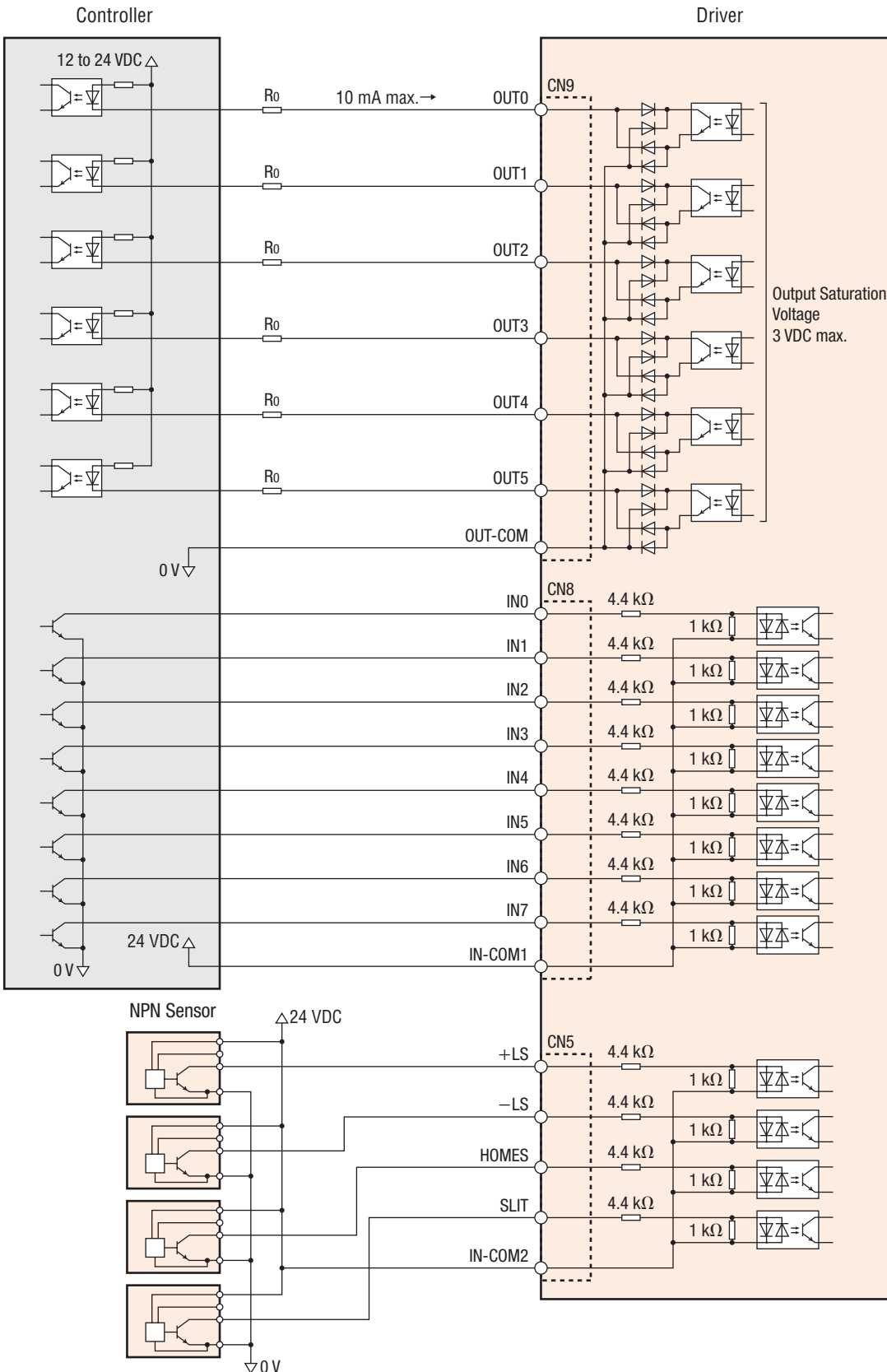

**Note**

- Use input signals at 24 VDC.
- Use output signals at 24 VDC or less. If the current exceeds 10 mA, connect an external resistor  $R_o$ .
- The saturation voltage of the output signal is 3 VDC max.
- Provide a minimum distance of 200 mm between the signal lines and power lines (AC lines, motor lines).  
Do not run the signal lines in the same duct as power lines nor bundle them with power lines.
- If noise generated by the motor cable or power supply cable causes a problem with the specific wiring or layout, shield the cable or use ferrite cores.

## Connection and Operation (Pulse Input Package)

### Names and Functions of Driver Parts

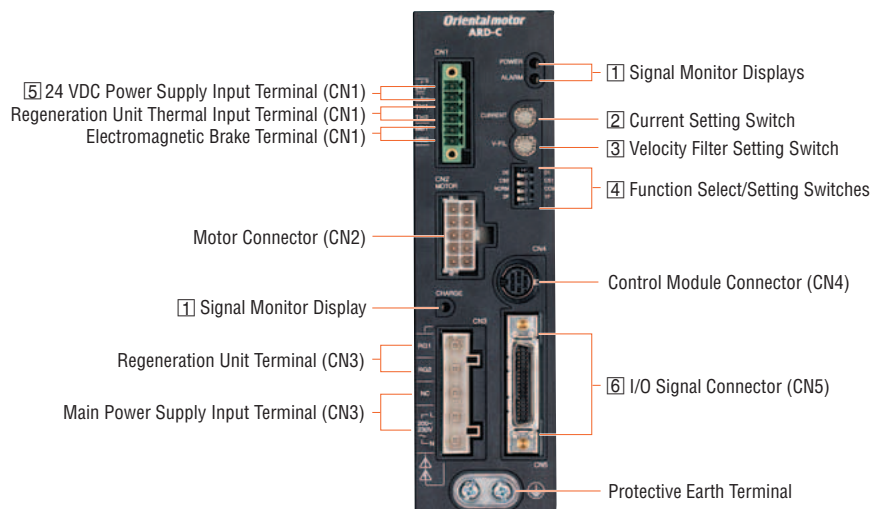

#### 1 Signal Monitor Displays

##### ◇ LED Displays

Indication	Color	Function	When Activated
POWER	Green	Power supply indication	Lights when main power or 24 VDC power is on.
ALARM	Red	Alarm indication	Blinks when protective functions are activated.
CHARGE	Red	Power supply indication	Lights when main power is on.

##### ◇ Alarms

Blink Count	Function	When Activated
2	Overheat	The temperature inside the driver rises above 85°C.
	Overload	When the amount of time during which the load torque exceeded the maximum torque exceeds the overload detection time. (Default value: 5 seconds)
	Overspeed	The motor output shaft speed exceeds 4500 r/min.
	Command pulse error	The command pulse value becomes abnormal.
	Regeneration unit overheat	The thermostat for regeneration unit signal is activated.
3	Overvoltage	The primary voltage of the driver's inverter exceeds the upper limit.
	Main power supply error	The main power is cut off when an operation command is input.
	Undervoltage	The primary voltage of the driver's inverter drops below the lower limit.
4	Overflow rotation during current on	The position deviation exceeds the overflow revolutions. (Default value: 3 revolutions)
	Overflow rotation during current off	The current is turned on even though the position deviation when the current is turned off was equal to or greater than the permissible value. (Default value: 100 revolutions or more)
5	Overcurrent	An excessive current flows through the inverter power element inside the driver.
	Drive circuit error	The power cable of the motor is disconnected.
7	Abnormal operation data	Return to electrical home operation is performed while an operation data error warning is present.
	Electronic gear setting error	The resolution set by the electronic gear is outside the specified range.
8	Sensor error during operation	A sensor error occurs while the motor is rotating.
	Initial sensor error	The power source is turned on when the motor cable is not connected to the driver.
	Initial rotor rotation error	The main power is turned on while the motor is rotating.
9	Motor combination error	A motor not supported by the driver is connected.
	EEPROM error	A motor control parameter is damaged.

#### 2 Current Setting Switch

Indication	Switch Name	Function
CURRENT	Current setting switch	This switch adjusts the operating current. It is used to limit the torque and temperature rise. A desired current can be set as a percentage (%) of the rated output current. The factory setting is "F."

#### 3 Velocity Filter Setting Switch

Indication	Switch Name	Function
V-FIL	Velocity filter setting switch	<p>This switch adjusts the motor response. Adjust the switch if you want to suppress motor vibration or cause the motor to start/stop smoothly. "0" and "F" correspond to the minimum and maximum velocity filter settings, respectively. The factory setting is "1."</p>

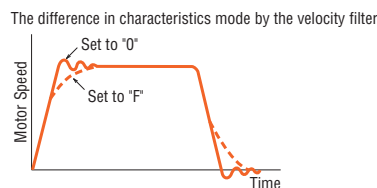

4 Function Select/Setting Switches

Indication	Switch Name	Function
DO/D1	Resolution select switches	These switches are used to set the resolution per rotation of the motor output shaft. "D0" "CS0" → 1000 pulse <0.36°/step> [Factory setting] "D0" "CS1" → 10000 pulse <0.036°/step> "D1" "CS0" → 500 pulse <0.72°/step> "D1" "CS1" → 5000 pulse <0.072°/step>
CS0/CS1		
NORM/CCM	Control mode select switches	This switch toggles the driver between the normal mode and current control mode. In the current control mode, noise and vibration can be reduced although the motor synchronicity may reduce. "NORM": Normal mode [Factory setting] "CCM": Current control mode
2P/1P	Pulse input mode switch	The settings of this switch are compatible with the following two types of pulse input modes: "1P" for the 1-pulse input mode [Factory setting], "2P" for the 2-pulse input mode.

5 24 VDC Power Supply Input/Regeneration Unit Thermal Input/Electromagnetic Brake Terminal (CN1)

Indication	Input/Output	Terminal Name	Description
24V+	Input	24 VDC power supply input terminal+	Connect a power supply to these terminals if you want to supply the control power separately from the main power. Supply of the control power is optional. If you are using an electromagnetic brake motor, connect a power supply to these terminals for the electromagnetic brake power.
24V-		24 VDC power supply input terminal-	
TH1		Regeneration unit thermal input terminal	Connect the accessory regeneration unit <b>RGB100</b> (sold separately). If no regeneration unit is used, short the TH1 and TH2 terminals of CN1.
TH2		Regeneration unit thermal input terminal	
MB1	Output	Electromagnetic brake terminal-	Connect the lead wires from the electromagnetic brake.
MB2		Electromagnetic brake terminal+	

6 I/O Signal Connector (CN5, 36 pins)

Indication	Input/Output	Pin No.	Signal		Signal Name	
			Positioning Operation	Push-Motion Operation*1	Positioning Operation	Push-Motion Operation*1
CN5	-	1	-	-	-	-
		2	GND		Ground connection	
	Output	3	ASG+		A-phase pulse output (line driver)	
		4	ASG-			
		5	BSG+		B-phase pulse output (line driver)	
		6	BSG-			
		7	TIM1+		Timing output (line driver)	
		8	TIM1-			
		9	ALM+		Alarm output	
		10	ALM-			
		11	WNG+		Warning output	
		12	WNG-			
		13	END+		Positioning complete output	
		14	END-			
		15	READY+/ALO+*1		Operation ready complete output/Alarm code output 0*1	
		16	READY-/ALO-*1			
	17	TLC+/AL1+*1		Torque limit output /Alarm code output 1*1		
	18	TLC-/AL1-*1				
	19	TIM2+/AL2+*1		Timing output (open-collector)/Alarm code output 2*1		
	20	TIM2-/AL2-*1				
	Input	21	GND		Ground connection	
		22	IN-COM		Input signal common	
		23	C-ON*2		Current on input*2	
		24	CLR/ALM-RST		Deviation counter clear input/Alarm reset input	
		25	CCM		Current control mode ON input	
		26	CS	T-MODE*1	Resolution select input	Push-motion operation ON*1
		27	-	M0*1	-	Push-current setting select input*1
		28	RETURN	M1*1	Return to electrical home operation	
		29	P-RESET	M2*1	Position reset input	
		30	FREE		Electromagnetic brake release, excitation OFF	
		31	PLS+/CW+		Pulse input/CW pulse input (+5 V/line driver)	
		32	PLS-/CW-			
		33	PLS+24/CW+24V		Pulse input/CW pulse input (+24 V)	
		34	DIR+24/CCW+24V		Direction input/CCW pulse input (+24 V)	
		35	DIR+/CCW+		Direction input/CCW pulse input (+5 V/line driver)	
		36	DIR-/CCW-			

\*1 The signal will become effective if the applicable setting has been changed using the accessory control module **OPX-2A** or the data setting software **MEXE02** (both sold separately).

\*2 The factory setting of the C-ON input is normally open. Be sure to turn the C-ON input ON when operating the motor. Set the C-ON input to normally close with a control module (**OPX-2A**, sold separately) or a data setting software (**MEXE02**, sold separately) when the C-ON input is not used.

## ● Connection Diagram

### ◇ Connection to Peripheral Equipment

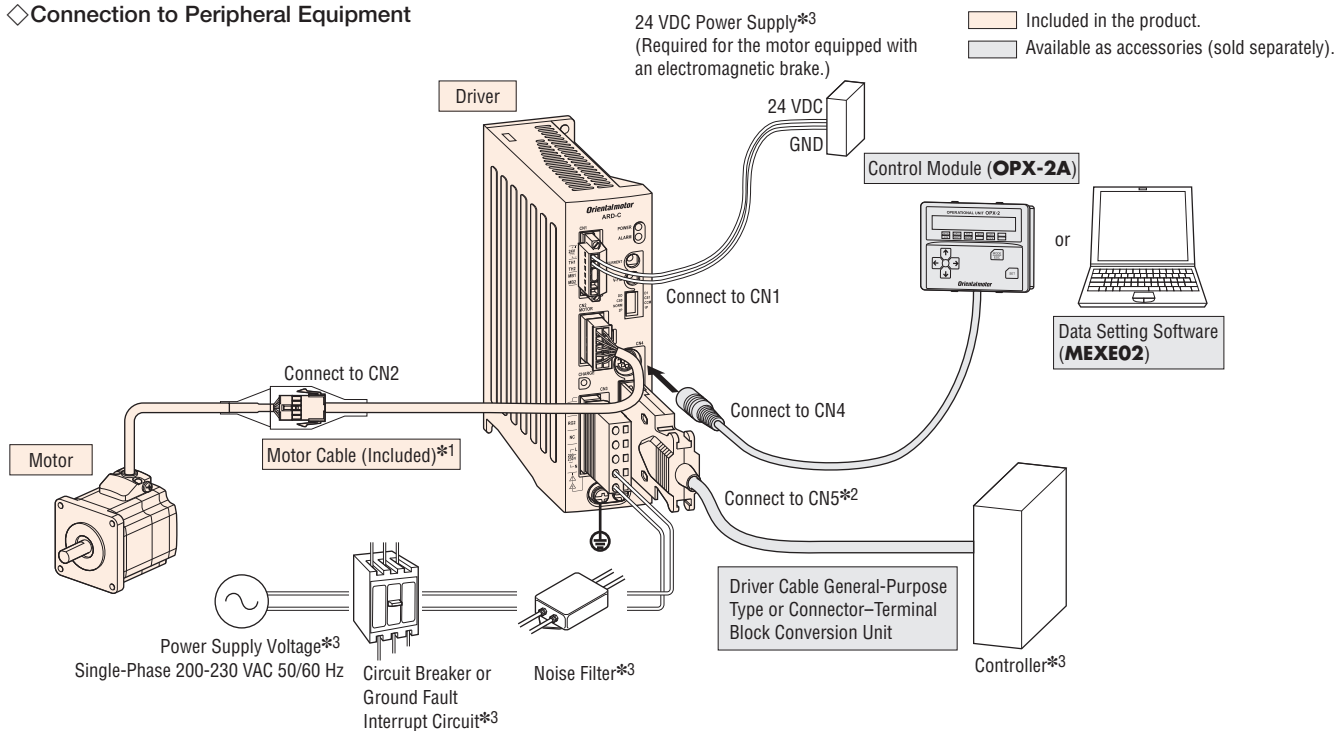

- \*1 Each model comes with a motor cable 1 m, 2 m or 3 m long. If you need a cable of a different length or a flexible cable, select an appropriate cable from among the accessories (sold separately).
- \*2 Each model comes with a control I/O connector (CN5), but you must select the driver cable general-purpose type or connector-terminal block conversion unit, both of which are provided as accessories (sold separately).
- \*3 Not supplied.

### ◇ Connecting a Main Power Supply

Use the following cable for the power supply line;  
3-core cable of AWG16 to 14 (1.25 to 2.0 mm<sup>2</sup>)

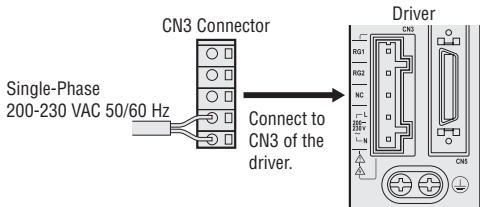

### ◇ Connecting the Control Power Supply

Provide a 24 VDC power supply if you want to supply the control power separately from the main power. Supply of the control power is optional.

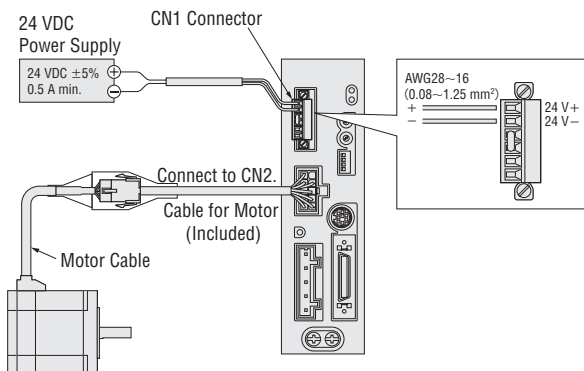

### ◇ Connecting the Electromagnetic Brake

Provide a 24 VDC power supply.  
Control power for the electromagnetic brake motor is separated from the main power.

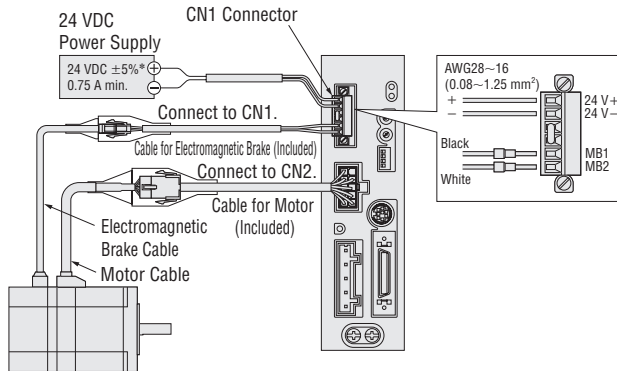

\*If the distance between the motor and driver is extended to 20 m or longer, use a power supply of 24 VDC ±4%.

Introduction
0.36°/Geared C-Series AR AC Input Motor & Driver
0.72°/Geared RK
0.36°/Geared C-Series AR
0.36°/0.72°/ Geared CRK DC Input Motor & Driver
1.8°/Geared RRK
0.9°/1.8°/Geared CMK
0.72° PK
1.8°/Geared High-Torque PKP Motor Only
0.9°/1.8°/Geared PK
Controllers SG8030JY
Accessories



◇ Connecting to a Host Controller

● Connecting to a Current Source Output Circuit

When pulse input is of line driver type

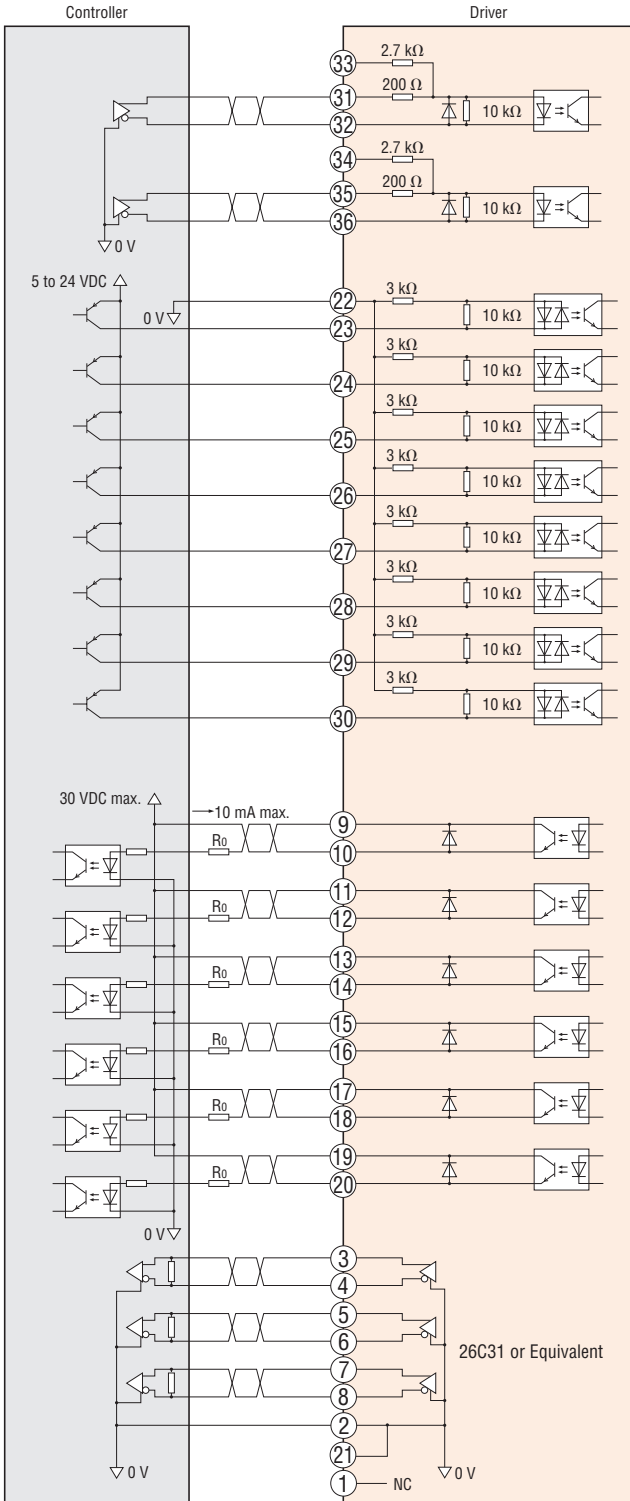

When pulse input is of 5 VDC type

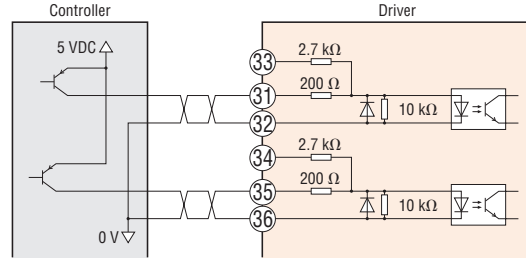

When pulse input is of 24 VDC type

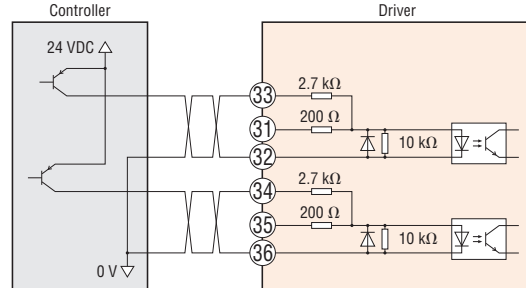

**Note**

- Use output signals at 30 VDC or less. If the current exceeds 10 mA, connect an external resistor  $R_o$ .
- Connect a terminal resistor of 100  $\Omega$  or more between the input of the line receiver terminals.
- Use a multi-core, twisted-pair shielded wire of AWG28 to 24 (0.08 to 0.2 mm<sup>2</sup>) for the control input/output signal line (CN5), and keep wiring as short as possible (within 2 m).
- Note that as the length of the pulse signal line increases, the maximum transmission frequency decreases.
- Provide a minimum distance of 200 mm between the control I/O signal lines and power lines (AC lines, motor lines and other large-current circuits).



## ◇ Connecting to a Host Controller

### ● Connecting to a Current Sink Output Circuit

When pulse input is of line driver type

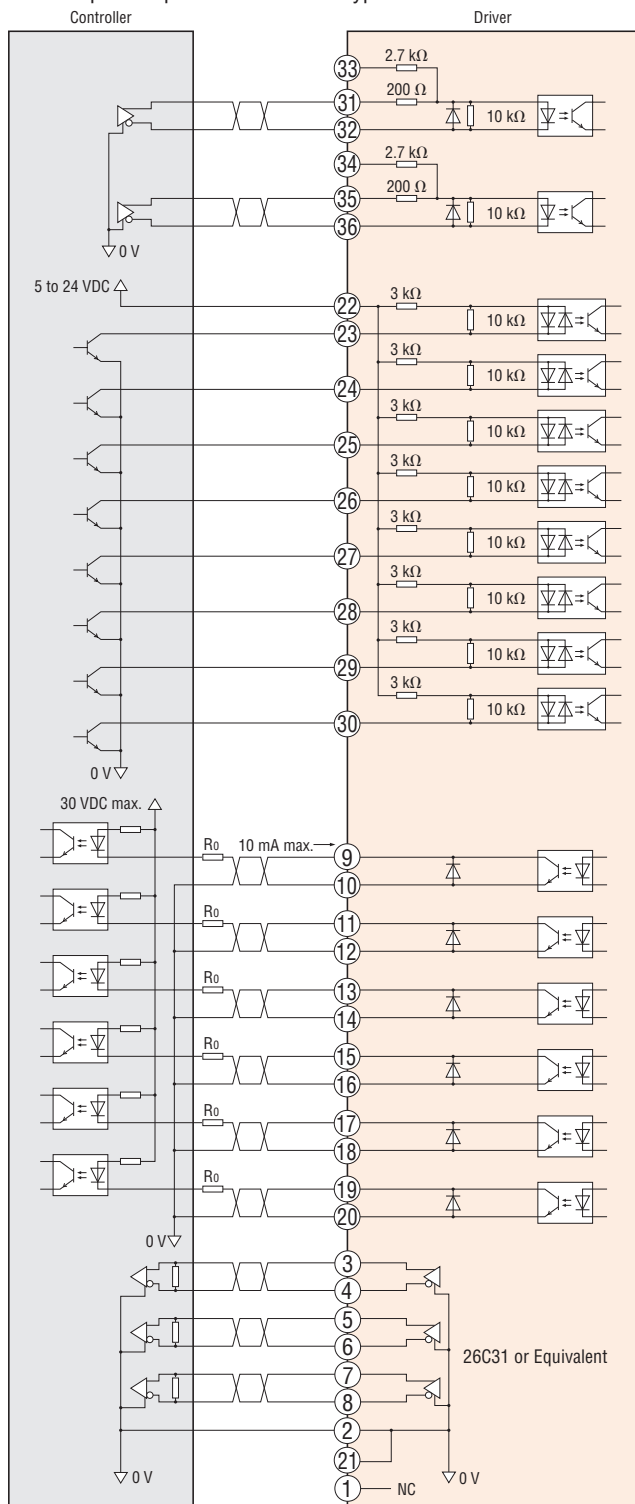

When pulse input is of 5 VDC type

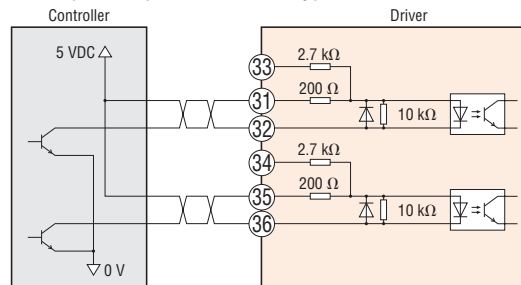

When pulse input is of 24 VDC type

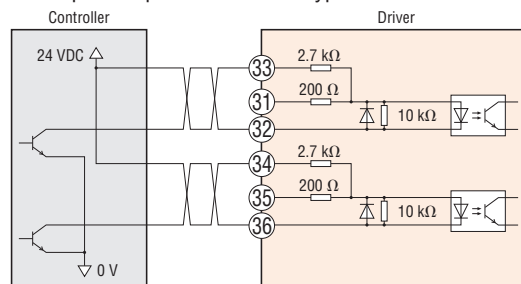

### Note

- Use output signals at 30 VDC or less. If the current exceeds 10 mA, connect an external resistor  $R_o$ .
- Connect a terminal resistor of 100  $\Omega$  or more between the input of the line receiver terminals.
- Use a multi-core, twisted-pair shielded wire of AWG28 to 24 (0.08 to 0.2 mm<sup>2</sup>) for the control input/output signal line (CN5), and keep wiring as short as possible (within 2 m).
- Note that as the length of the pulse signal line increases, the maximum transmission frequency decreases.
- Provide a minimum distance of 200 mm between the control I/O signal lines and power lines (AC lines, motor lines and other large-current circuits).

## Motor and Driver Combinations

Product names for motor and driver combinations are shown below.

Type	Built-In Controller Package			Pulse Input Package		
	Product Name	Motor Product Name	Driver Product Name	Product Name	Motor Product Name	Driver Product Name
Standard Type	<b>AR46</b> □ <b>CD</b> -◇*	ARM46□C	ARD-CD	<b>AR46</b> □ <b>C</b> -◇*	ARM46□C	ARD-C
	<b>AR66</b> □ <b>CD</b> -◇*	ARM66□C		<b>AR66</b> □ <b>C</b> -◇*	ARM66□C	
	<b>AR69</b> □ <b>CD</b> -◇*	ARM69□C		<b>AR69</b> □ <b>C</b> -◇*	ARM69□C	
	<b>AR98</b> □ <b>CD</b> -◇*	ARM98□C		<b>AR98</b> □ <b>C</b> -◇*	ARM98□C	
	<b>AR911</b> □ <b>CD</b> -◇*	ARM911□C		<b>AR911</b> □ <b>C</b> -◇*	ARM911□C	
TH Geared Type	<b>AR46</b> □ <b>CD-T</b> □-◇	ARM46□C-T□		<b>AR46</b> □ <b>C-T</b> □-◇	ARM46□C-T□	
	<b>AR66</b> □ <b>CD-T</b> □-◇	ARM66□C-T□		<b>AR66</b> □ <b>C-T</b> □-◇	ARM66□C-T□	
	<b>AR98</b> □ <b>CD-T</b> □-◇	ARM98□C-T□		<b>AR98</b> □ <b>C-T</b> □-◇	ARM98□C-T□	
PS Geared Type	<b>AR46</b> □ <b>CD-PS</b> □-◇	ARM46□C-PS□		<b>AR46</b> □ <b>C-PS</b> □-◇	ARM46□C-PS□	
	<b>AR66</b> □ <b>CD-PS</b> □-◇	ARM66□C-PS□		<b>AR66</b> □ <b>C-PS</b> □-◇	ARM66□C-PS□	
	<b>AR98</b> □ <b>CD-PS</b> □-◇	ARM98□C-PS□		<b>AR98</b> □ <b>C-PS</b> □-◇	ARM98□C-PS□	
PN Geared Type	<b>AR46</b> □ <b>CD-N</b> □-◇	ARM46□C-N□		<b>AR46</b> □ <b>C-N</b> □-◇	ARM46□C-N□	
	<b>AR66</b> □ <b>CD-N</b> □-◇	ARM66□C-N□		<b>AR66</b> □ <b>C-N</b> □-◇	ARM66□C-N□	
	<b>AR98</b> □ <b>CD-N</b> □-◇	ARM98□C-N□		<b>AR98</b> □ <b>C-N</b> □-◇	ARM98□C-N□	
Harmonic Geared Type	<b>AR46</b> □ <b>CD-H</b> □-◇	ARM46□C-H□		<b>AR46</b> □ <b>C-H</b> □-◇	ARM46□C-H□	
	<b>AR66</b> □ <b>CD-H</b> □-◇	ARM66□C-H□	<b>AR66</b> □ <b>C-H</b> □-◇	ARM66□C-H□		
	<b>AR98</b> □ <b>CD-H</b> □-◇	ARM98□C-H□	<b>AR98</b> □ <b>C-H</b> □-◇	ARM98□C-H□		

● **A** (Single shaft) or **M** (Electromagnetic brake) indicating the type is entered where the box □ is located within the product name.

A number indicating the gear ratio is entered where the box ■ is located within the product name, A number indicating the desired length of **1** (1 m), **2** (2 m) or **3** (3 m) for the cable indicated with the product is entered where the box ◇ is located within the product name.

\***A** (Single shaft), **B** (Double shaft) or **M** (Electromagnetic brake) indicating the type is entered where the box □ is located within the product name of **AR46**□**C(D)**-◇, **AR66**□**C(D)**-◇, **AR69**□**C(D)**-◇ and **AR98**□**C(D)**-◇.

**A** (Single shaft), **B** (Double shaft) indicating the type is entered where the box □ is located within the product name of **AR911**□**C(D)**-◇.