

## Motor Only/Driver Only

Overview,  
Product  
Series

AC Input  
Motor &  
Driver

0.36°/Geared  
**αSTEP**  
Absolute  
**AZ**

0.36°/Geared  
**αSTEP**  
**AR**

0.72°/Geared  
**RKII**

DC Input  
Motor &  
Driver

0.36°/Geared  
**αSTEP**  
Absolute  
**AZ**

0.36°/Geared  
**αSTEP**  
**AR**

1.8°/0.72°  
/0.36°  
**CVK**

0.72°/0.36°  
/Geared  
**CRK**

1.8°/Geared  
**RBK**

Motor Only  
/Driver Only

1.8°/0.9°  
**PKP/PK**

Geared  
**PKP/PK**

0.72°/0.36°  
**PKP/PK**

Driver

Accessories

1.8°, 0.9°  
**PKP Series/PK Series**

Geared  
**PKP Series/PK Series**

0.72°, 0.36°  
**PKP Series/PK Series**

Driver

Page

1.8°, 0.9° <b>PKP Series/PK Series</b> .....	A-352
Geared <b>PKP Series/PK Series</b> .....	A-417
0.72°, 0.36° <b>PKP Series/PK Series</b> .....	A-432
Driver .....	A-438

# 1.8°/0.9° Stepper Motors PKP Series/PK Series

<Additional Information>  
 ● Technical reference → Page H-1  
 ● Regulations & Standards → Page I-2

● For detailed information about regulations and standards, please see the Oriental Motor website.



These products are high-torque 1.8°/0.9° stepper motors. A wide variety of products is available for selecting a motor that meets your design specifications.

- Standard Type with a Resolution of 200 Steps per Revolution (Basic step angle: 1.8°/step)
- High-Resolution Type with a Resolution of 400 Steps per Revolution (Basic step angle: 0.9°/step)
- Oriental Motor's Flattest Type of 1.8° Stepper Motor
- High-Torque and High-Resolution **SH** Geared Type
- Bipolar (4 lead wires) and Unipolar (5 or 6 lead wires) Are Available.
- Type with Encoder and Type with an Electromagnetic Brake Are Available.
- There is a Wide Variety of Motor Current Specifications.

## Features

### Increased Torque over the Entire Speed Range from Low to High

After revising the magnetic design and structure design of the **PKP** Series, it produces much more torque than standard **PK** Series motors of the same size. In addition, torque can be increased in the high-speed range by using high current motors.

Comparison of Speed – Torque Characteristics of the Same Size Motors

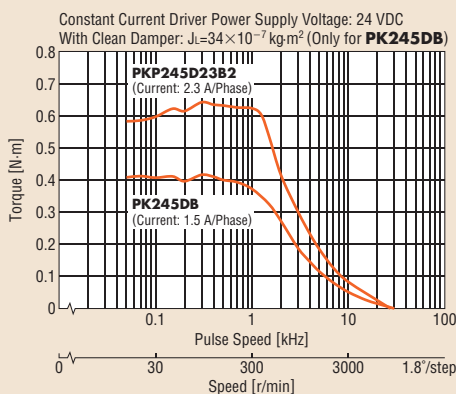

High current is possible due to the revised motor winding design and the highly efficient design of the drive circuit that can be combined. Increased torque over the entire speed range from low to high is achieved.

Comparison of Maximum Holding Torque

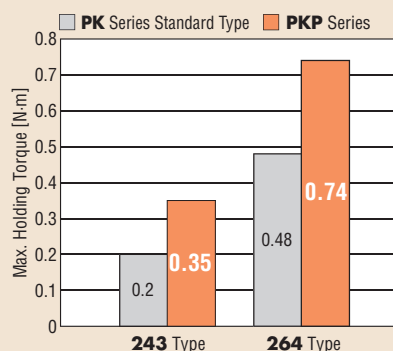

### Compact and Flat Connector

The **PKP** Series uses a compact and flat connector, which shortens the length of the connector's overhang. In addition, the degree of freedom for the cable outlet direction has been increased, because the outlet direction points upward.

● Because the connector is provided for some products only, refer to dimensions of each model for details.

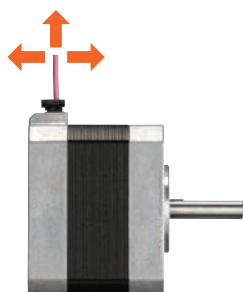

### Lower Vibration

Revising the magnetic design has achieved lower vibration than with conventional products.

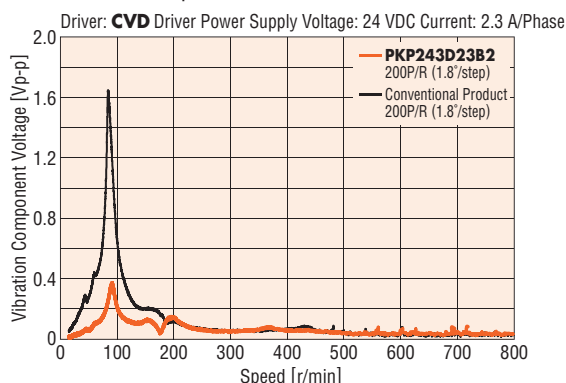

## Downsizing

Use a **PKP** Series motor in place of a standard motor from the **PK** series with the equivalent torque in order to downsize motors.

Comparison of Torque Characteristics of **PKP244U12A2** and **PK264-02A**

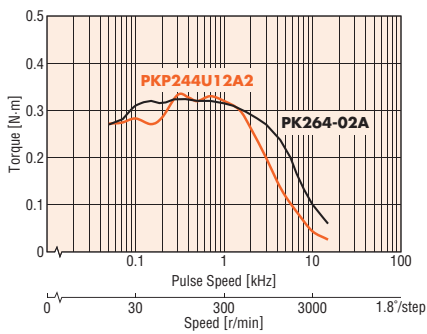

**Downsizing is Possible with the Same Torque!**

**PK264-02A** → **PKP244U12A2**

## High-Resolution Type

This is a high-resolution stepper motor with a basic step angle of 0.9°. Stopping accuracy is improved.

- **Increased Resolution (Compared to Standard Type)**  
The number of rotor teeth has doubled to 100, compared to 50 with the standard type. As a result, the basic step angle is 0.9°/step, which is half that of the standard type.

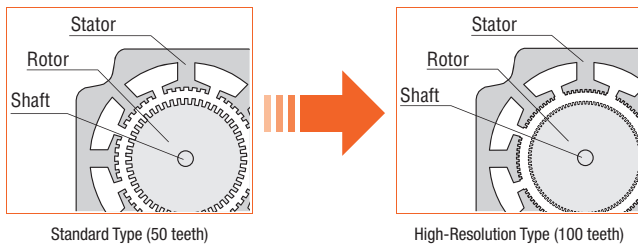

- **Avoidance of Resonance Regions**  
If the pulse speed is within a resonance region, vibration may increase. Resonance regions can be avoided by switching to a high-resolution type.

- **Improved Stopping Accuracy (Compared to Standard Type)**  
The stopping accuracy improves as the torque increases while minimizing the negative effects of frictional load.

Comparison of Angle – Torque Characteristics

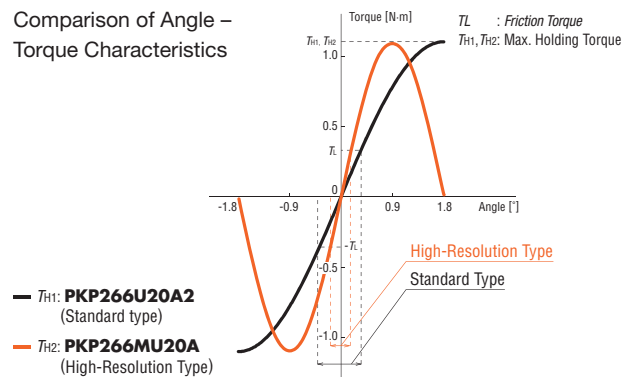

## Flat Type

This is Oriental Motor's flattest type of 1.8° stepper motors.

- **Flat and Lightweight Design**  
The motor can be installed in a narrow space by being flatter.

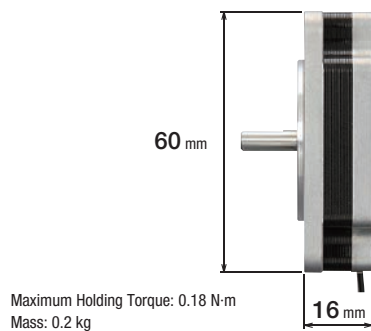

- **With Harmonic Gears**  
Products assembled with harmonic gears are also available. Attach the load to the surface of the flange to fix the load.

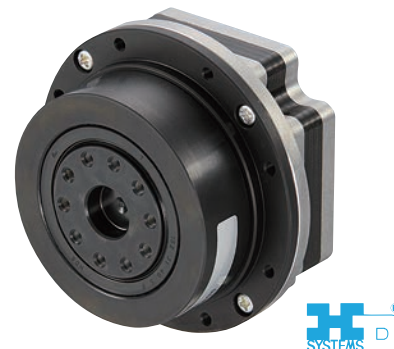

Maximum holding torque: 5.4 N·m  
Installation Size:  $\phi 72$  mm  
Mass: 0.6 kg

is a registered trademark of Harmonic Drive Systems Inc.

Overview, Product Series

AC Input Motor & Driver

0.36°/Geared  $\alpha$ STEP Absolute AZ

0.36°/Geared  $\alpha$ STEP AR

0.72°/Geared RKII

DC Input Motor & Driver

0.36°/Geared  $\alpha$ STEP Absolute AZ

0.36°/Geared  $\alpha$ STEP AR

1.8°/0.72°/0.36° CVK

0.72°/0.36°/Geared CRK

1.8°/Geared RBK

Motor Only /Driver Only

1.8°/0.9° PKP/PK

Geared PKP/PK

0.72°/0.36° PKP/PK

Driver

Accessories

## SH Geared Type

This type is advantageous for its deceleration, greater torque, higher resolution and anti-vibration measures. It experiences less backlash than conventional products. The increased speed range makes it even easier to use.

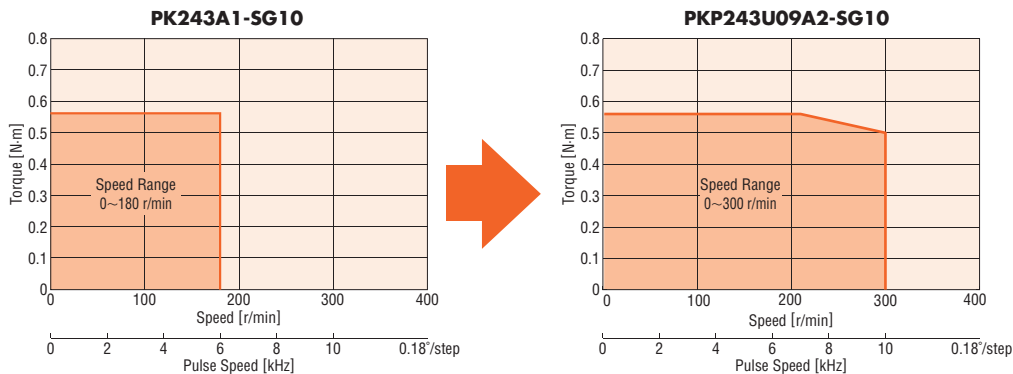

## Product Line Equipped with Additional Functions to Further Broaden Applications

### ● With Encoder

(Provided for standard type and high-resolution type)

Encoder Specifications → Page A-430

#### ● Main Specifications

Type	Standard Type	High-Resolution Type
Resolution	200 P/R, 400 P/R	400 P/R
Output Signal	A Phase, B Phase, Z Phase (3ch)	



#### ◇ Motor Position Detection is Possible.

Monitoring the current position and detecting positional errors are possible. For example, comparing the command position and current position enables you to check the normal operation of the motor.

#### ◇ Equipped with a Compact Encoder

● When frame size is 42 mm

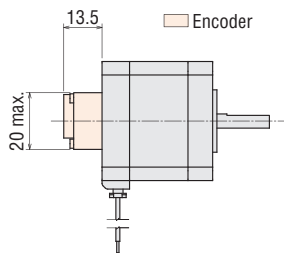

#### ◇ High Reliability with Line Driver Output Circuit Type

Noise resistance is improved by differential output, and the wiring distance can be longer than with the voltage output type.

### ● Type with an Electromagnetic Brake

(Provided for standard type and high-resolution type)

Electromagnetic Brake → Page A-430



#### ◇ Position Can Be Held When the Power Is OFF or a Power Failure Occurs.

This type features an electromagnetic brake that activates when the power is off.

When the power is accidentally cut off due to a power failure or other unexpected event, the electromagnetic brake holds the load in position to prevent it from dropping or moving. Also, the load can be held by the electromagnetic brake when the motor is stopped, and the heat generated by the motor can be curtailed by switching the motor current off.

● **Standard Type with Terminal Box**

Terminal boxes have excellent watertightness and dust-resistance. This product conforms to the IP65 motor specification for the degree of protection (excluding shaft penetration).

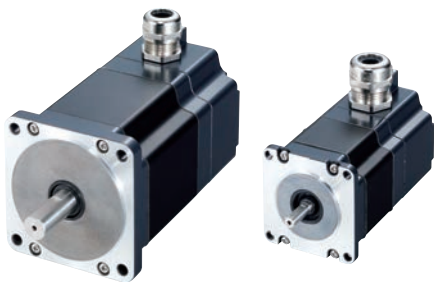

◇ **Terminal-Block Connection Design**

The motor can be wired directly from its terminal block.

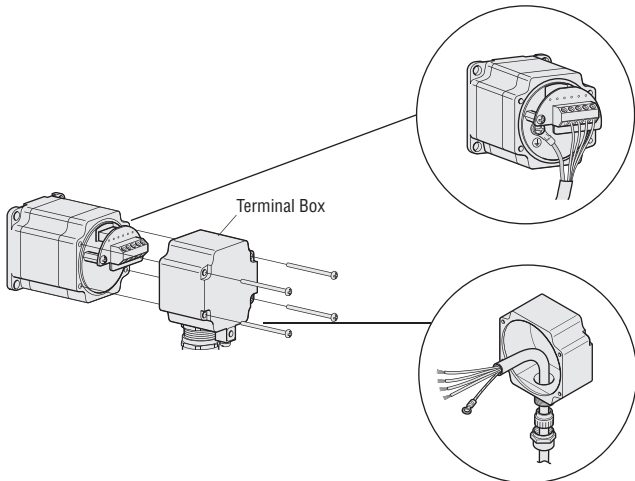

◇ **No Motor/Driver Relay**

Since the motor cable can be connected directly to the driver terminals, there is no need for wire connection or soldering on a relay terminal block.

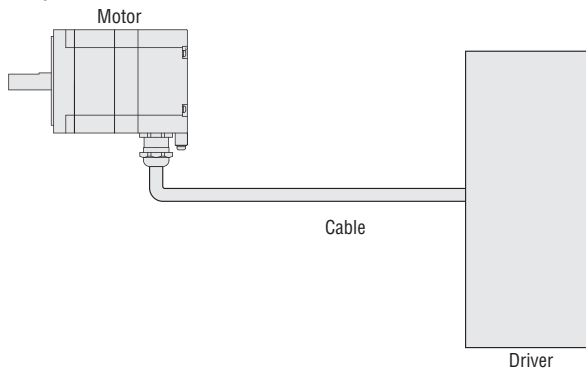

● **Standard Type with Cabtire Cable**

The motor conforms to the IP54 standard to changing the lead wire outlet from lead wire to cable and cable clamp (excluding the mounting surface.)

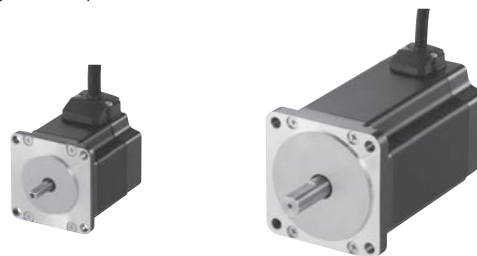

## Combined Drivers (Sold separately)

The compact and lightweight bipolar driver and unipolar driver are available.

● **Bipolar Drivers**

● **Right Angle Type with an Installation Plate**  
The connector points outward.



● **With an Installation Plate**  
The connector points upward.



● **Without an Installation Plate**  
The connector direction is upward.



● **Unipolar Driver**



Overview,  
Product  
Series

AC Input  
Motor &  
Driver

0.36°/Geared  
**αSTEP**  
Absolute  
**AZ**

0.36°/Geared  
**αSTEP**  
**AR**

0.72°/Geared  
**RKII**

DC Input  
Motor &  
Driver

0.36°/Geared  
**αSTEP**  
Absolute  
**AZ**

0.36°/Geared  
**αSTEP**  
**AR**

1.8°/0.72°  
/0.36°  
**CVK**

0.72°/0.36°  
/Geared  
**CRK**

1.8°/Geared  
**RBK**

Motor Only  
/Driver Only

1.8°/0.9°  
**PKP/PK**

Geared  
**PKP/PK**



0.72°/0.36°  
**PKP/PK**

Driver

Accessories



**Product Line of PKP Series, PK Series**

**Standard Type, High-Resolution Type, Flat Type**

Motor Product Line (Basic Step Angle)	Series/Frame Size, Wiring Type															
	PKP 20 mm		PKP 28 mm		PKP 35 mm		PKP 42 mm		PK 50 mm		PKP 56.4 mm*		PK 60 mm		PKP 85 mm	
	Bipolar	Unipolar	Bipolar	Unipolar	Bipolar	Unipolar	Bipolar	Unipolar	Bipolar	Unipolar	Bipolar	Unipolar	Bipolar	Unipolar	Bipolar	Unipolar
<b>Standard Type (1.8°)</b> 	○	○	●	●	●	●	●	●	-	○	●	●	○	○	○	○
	○	○	●	●	●	●	●	●	-	-	●	●	-	-	-	-
	-	-	●	●	●	●	●	●	-	-	●	●	-	-	-	-
	-	-	-	-	-	-	-	-	-	-	○ (PK)	-	-	-	○ (PK)	-
	-	-	-	-	-	-	-	-	-	-	● (PK)	-	-	-	● (PK)	● (PK)
<b>High-Resolution Type (0.9°)</b> 	-	-	-	-	-	-	●	●	-	-	●	●	-	-	-	-
	-	-	-	-	-	-	●	●	-	-	●	●	-	-	-	-
	-	-	-	-	-	-	●	●	-	-	●	●	-	-	-	-
<b>Flat Type (1.8°~0.018°)</b> 	-	-	-	-	-	-	-	-	-	-	○	-	-	-	-	-
	-	-	-	-	-	-	-	-	-	-	○	-	-	-	-	-

●: Connector-coupled motors or motors equipped with a terminal box ○: Cable or Lead Wire Type  
\*Flat type is 60 mm, flat type with harmonic gears is φ72 mm.

**Geared Type**

Motor Product Line (Basic Step Angle)	Series/Frame Size, Wiring Type									
	PKP 28 mm		PKP 42 mm		PKP 60 mm		PK 60 mm		PK 90 mm	
	Bipolar	Unipolar	Bipolar	Unipolar	Bipolar	Unipolar	Bipolar	Unipolar	Bipolar	Unipolar
<b>SH Geared Type (0.5°~0.05°)</b> 	●	●	●	●	●	●	-	-	-	○
<b>TH Geared Type (0.5°~0.05°)</b> 	-	-	○ (PK)	○ (PK)	-	-	○	○	-	-
<b>PS Geared Type (0.36°~0.18°)</b> 	● (PK)	-	-	-	-	-	-	-	-	-

●: Connector Connection Method ○: Lead Wire Type

## System Configuration

These accessories allow the 1.8°/0.9° Stepper Motor **PKP** Series to be used for various operations. An example of a system configuration with the **SCX11** controller is shown below.

\* Not supplied.

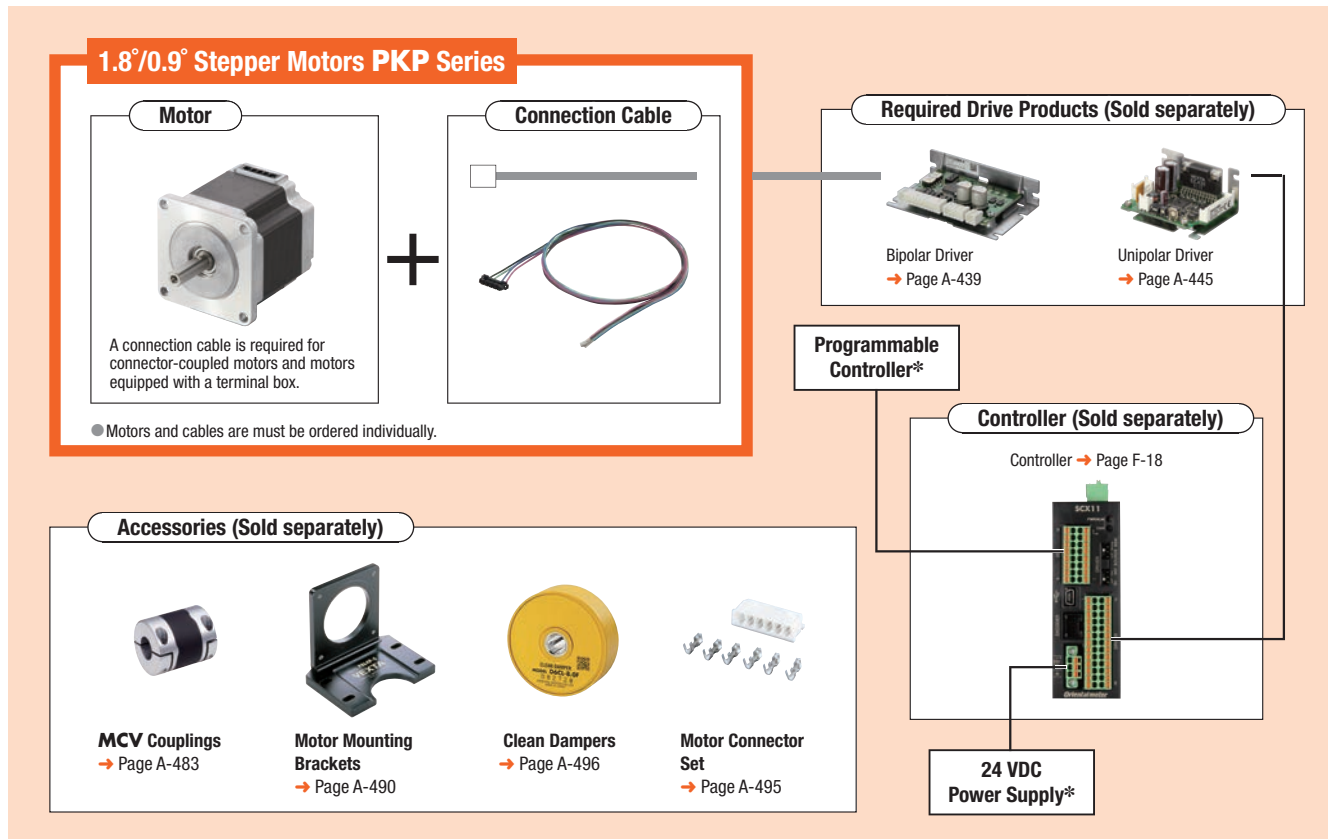

### ● Example of System Configuration

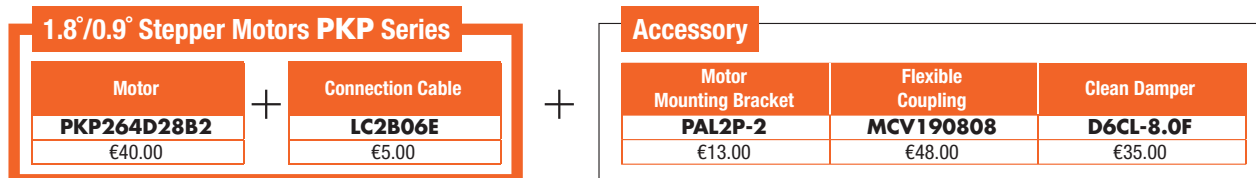

● The system configuration shown above is an example. Other combinations are also available.

Overview,  
Product  
Series

AC Input  
Motor &  
Driver

0.36°/Geared  
**αSTEP  
Absolute  
AZ**

0.36°/Geared  
**αSTEP  
AR**

0.72°/Geared  
**RKII**

DC Input  
Motor &  
Driver

0.36°/Geared  
**αSTEP  
Absolute  
AZ**

0.36°/Geared  
**αSTEP  
AR**

1.8°/0.72°  
/0.36°  
**CVK**

0.72°/0.36°  
/Geared  
**CRK**

1.8°/Geared  
**RBK**

Motor Only  
/Driver Only

1.8°/0.9°  
**PKP/PK**

Geared  
**PKP/PK**

0.72°/0.36°  
**PKP/PK**

Driver

Accessories

**Product Number**

● **Motor**

**PKP Series**

◇ Standard Type/Standard Type with Electromagnetic Brake

**PKP 2 6 4 D 28 A 2**

① ② ③ ④ ⑦ ⑧ ⑨ ⑩

◇ High-Resolution Type/High-Resolution Type with Electromagnetic Brake

**PKP 2 6 4 M D 28 A**

① ② ③ ④ ⑥ ⑦ ⑧ ⑨

◇ Flat Type

**PKP 2 6 2 F D 15 A W**

① ② ③ ④ ⑤ ⑦ ⑧ ⑨ ⑩

①	Series Name	<b>PKP: PKP Series</b>
②	2: 1.8°/0.9° Stepper Motor	
③	Motor Frame Size	<b>1:</b> 20 mm <b>2:</b> 28 mm <b>3:</b> 35 mm <b>4:</b> 42 mm <b>6:</b> 56.4 mm (60 mm when the motor classification is "F") <b>9:</b> 85 mm
④	Motor Case Length	
⑤	Motor Classification	<b>F:</b> Motor Frame Size of 60 mm
⑥	Motor Type	Blank: Standard Type <b>M:</b> High-Resolution Type
⑦	Number of Lead Wires	<b>D:</b> 4 Leads <b>U:</b> 5 or 6 Leads
⑧	Motor Winding Specifications	
⑨	Configuration	<b>A:</b> Single Shaft <b>B:</b> Double Shaft <b>M:</b> With Electromagnetic Brake
⑩	Reference Number	
⑪	Cable Identification	Blank: Connector Connection Method or Lead Wire Type <b>W:</b> Lead Wire Type

◇ Standard Type with Encoder

**PKP 2 4 3 D 15 A 2 - R2F L**

① ② ③ ④ ⑥ ⑦ ⑧ ⑨ ⑩ ⑪

◇ High-Resolution Type with Encoder

**PKP 2 4 3 M D 15 A - R2F L**

① ② ③ ④ ⑤ ⑥ ⑦ ⑧ ⑩ ⑪

①	Series Name	<b>PKP: PKP Series</b>
②	2: 1.8°/0.9° Stepper Motor	
③	Motor Frame Size	<b>1:</b> 20 mm <b>2:</b> 28 mm <b>3:</b> 35 mm <b>4:</b> 42 mm <b>6:</b> 56.4 mm
④	Motor Case Length	
⑤	Motor Type	Blank: Standard Type <b>M:</b> High-Resolution Type
⑥	Number of Lead Wires	<b>D:</b> 4 Leads <b>U:</b> 5 or 6 Leads
⑦	Motor Winding Specifications	
⑧	Configuration	<b>A:</b> Single Shaft
⑨	Reference Number	
⑩	Encoder Resolution	<b>R2E:</b> 200P/R <b>R2F:</b> 400P/R
⑪	Encoder Output Circuit Type	<b>L:</b> Line Driver Output*

\*Encoder of voltage output for output circuit type is also available. For details, please contact your nearest Oriental Motor sales office.

◇ Flat Type with Harmonic Gears

**PKP 2 6 2 F D 15 A W - H 100**

① ② ③ ④ ⑤ ⑥ ⑦ ⑧ ⑨ ⑩ ⑪

①	Series Name	<b>PKP: PKP Series</b>
②	2: 1.8° Stepper Motor	
③	Motor Frame Size	<b>6:</b> 60 mm (The type with harmonic gears is $\phi 72$ mm)
④	Motor Case Length	
⑤	Motor Classification	<b>F:</b> Motor Frame Size of 60 mm
⑥	Number of Lead Wires	<b>D:</b> 4 Leads
⑦	Motor Winding Specifications	
⑧	Configuration	<b>A:</b> Single Shaft
⑨	Cable Identification	<b>W:</b> Lead Wire Type
⑩	Geared Type	<b>H:</b> Harmonic Geared Type
⑪	Gear Ratio	

◇ SH Geared Type

**PKP 2 4 3 U 09 B 2 - SG 18**

① ② ③ ④ ⑤ ⑥ ⑦ ⑧ ⑨ ⑩

①	Series Name	<b>PKP: PKP Series</b>
②	2: 1.8° Stepper Motor	
③	Motor Frame Size	<b>2:</b> 28 mm <b>4:</b> 42 mm <b>6:</b> 60 mm
④	Motor Case Length	
⑤	Number of Lead Wires	<b>D:</b> 4 Leads <b>U:</b> 5 or 6 Leads
⑥	Motor Winding Specifications	
⑦	Configuration	<b>A:</b> Single Shaft <b>B:</b> Double Shaft
⑧	Reference Number	
⑨	Gear Type	<b>SG: SH</b> geared Type
⑩	Gear Ratio	

**PK Series**

◇ Standard Type

**PK 2 6 4 J D B**

① ② ③ ④ ⑤ ⑥ ⑦

①	Series Name	<b>PK: PK Series</b>
②	2: 1.8° Stepper Motor	
③	Motor Frame Size	<b>6:</b> 60 mm
④	Motor Case Length	
⑤	Motor Type	<b>J:</b> High-Torque Type
⑥	Number of Lead Wires	Blank: 6 Leads <b>D:</b> 4 Leads
⑦	Configuration	<b>A:</b> Single Shaft <b>B:</b> Double Shaft

◇ Standard Type (Unipolar 6 lead wires)

**PK 2 5 6 - 0 2 B**

① ② ③ ④ ⑤ ⑥ ⑦

①	Series Name	<b>PK: PK Series</b>
②	2: 1.8° Stepper Motor	
③	Motor Frame Size	<b>5:</b> 50 mm
④	Motor Case Length	
⑤	Reference Number	
⑥	Motor Winding Specifications	
⑦	Configuration	<b>A:</b> Single Shaft <b>B:</b> Double Shaft



◇ Standard Type with Cabtire Cable  
Standard Type with Terminal Box

## PK 2 9 6 E A T

①	Series Name	<b>PK: PK Series</b>
②	2: 1.8° Stepper Motor	
③	Motor Frame Size	<b>6:</b> 56.4 mm <b>9:</b> 85 mm
④	Motor Case Length	
⑤	Number of Lead Wires or Motor Terminals	<b>D, D1:</b> 4 Leads, 4 Terminals <b>E:</b> 8 Terminals
⑥	Motor Shaft Type	<b>A:</b> Single Shaft
⑦	Motor Type	<b>W:</b> With Cabtire Cable <b>T:</b> With Terminal Box

● Connection Cable

◇ Connection Cable for Motor

## LC 2 B 06 A

①	Cable	<b>LC:</b> Connector Leads
②	2: 1.8°/0.9° Stepper Motor	
③	Cable Type	<b>B:</b> For Bipolar <b>U:</b> For Unipolar
④	Cable Length	<b>06:</b> 0.6 m <b>10:</b> 1 m
⑤	Reference number	

◇ Geared Type

## PK 2 9 6 A E - SG 10

①	Series	<b>PK: PK Series</b>
②	2: 1.8° Stepper Motor	
③	Motor Frame Size	<b>2:</b> 28 mm <b>4:</b> 42 mm <b>6:</b> 60 mm <b>9:</b> 90 mm
④	Motor Case Length	
⑤	Motor Type	
⑥	Number of Lead Wires	<b>1</b> or <b>2:</b> 6 Leads <b>D:</b> 4 Leads <b>E:</b> 8 Leads
⑦	Shaft Type	<b>A:</b> Single Shaft <b>B:</b> Double Shaft
⑧	Gearhead Type	<b>SG: SH</b> Geared Type <b>T: TH</b> Geared Type <b>PS: PS</b> Geared Type
⑨	Gear Ratio	

◇ Connection Cable for Encoder

## LC E 08 A - 006

①	Cable	<b>LC:</b> Connector Leads
②	Cable Type	<b>E:</b> For Encoder
③	Applicable Models	<b>08:</b> For Line Driver Output*
④	Reference Number	
⑤	Cable Length	<b>006:</b> 0.6 m

\*The voltage output cable is also available.

For details, please contact your nearest Oriental Motor sales office.

Overview, Product Series

AC Input Motor & Driver

0.36°/Geared  
**αSTEP Absolute AZ**

0.36°/Geared  
**αSTEP AR**

0.72°/Geared  
**RKII**

DC Input Motor & Driver

0.36°/Geared  
**αSTEP Absolute AZ**

0.36°/Geared  
**αSTEP AR**

1.8°/0.72°/0.36°  
**CVK**

0.72°/0.36°/Geared  
**CRK**

1.8°/Geared  
**RBK**

Motor Only /Driver Only

1.8°/0.9°  
**PKP/PK**

Geared  
**PKP/PK**

0.72°/0.36°  
**PKP/PK**

Driver

Accessories

## Product Line

### ● Motor

#### ◇ Standard Type

##### ● Bipolar (4 Lead Wires)

Product Name (Single Shaft)	List Price	Product Name (Double Shaft)	List Price
PKP213D05A	€44.00	PKP213D05B	€46.00
PKP214D06A	€47.00	PKP214D06B	€49.00
PKP223D15A2	€30.00	PKP223D15B2	€32.00
PKP225D15A2	€36.00	PKP225D15B2	€38.00
PKP233D15A	€30.00	PKP233D15B	€32.00
PKP233D23A	€30.00	PKP233D23B	€32.00
PKP235D15A	€36.00	PKP235D15B	€38.00
PKP235D23A	€36.00	PKP235D23B	€38.00
PKP243D15A2	€30.00	PKP243D15B2	€32.00
PKP243D23A2	€30.00	PKP243D23B2	€32.00
PKP244D15A2	€32.00	PKP244D15B2	€34.00
PKP244D23A2	€32.00	PKP244D23B2	€34.00
PKP245D15A2	€36.00	PKP245D15B2	€38.00
PKP245D23A2	€36.00	PKP245D23B2	€38.00
PKP246D15A2	€38.00	PKP246D15B2	€40.00
PKP246D23A2	€38.00	PKP246D23B2	€40.00
PKP264D14A2	€38.00	PKP264D14B2	€40.00
PKP264D28A2	€38.00	PKP264D28B2	€40.00
PKP264D42A2	€38.00	PKP264D42B2	€40.00
PKP266D14A2	€42.00	PKP266D14B2	€44.00
PKP266D28A2	€42.00	PKP266D28B2	€44.00
PKP266D42A2	€42.00	PKP266D42B2	€44.00
PKP268D14A2	€52.00	PKP268D14B2	€54.00
PKP268D28A2	€52.00	PKP268D28B2	€54.00
PKP268D42A2	€52.00	PKP268D42B2	€54.00
PK264JDA	€74.00	PK264JDB	€77.00
PK266JDA	€81.00	PK266JDB	€84.00
PK267JDA	€96.00	PK267JDB	€99.00
PK269JDA	€120.00	PK269JDB	€124.00
PKP296D45A	€89.00	PKP296D45B	€96.00
PKP296D63A	€89.00	PKP296D63B	€96.00
PKP299D45A	€137.00	PKP299D45B	€144.00
PKP299D63A	€137.00	PKP299D63B	€144.00
PKP2913D45A	€173.00	PKP2913D45B	€180.00
PKP2913D56A	€173.00	PKP2913D56B	€180.00

#### ◇ Standard Type with Encoder

##### ● Bipolar (4 Lead Wires)

Product Name (Encoder Resolution: 200 P/R)	List Price	Product Name (Encoder Resolution: 400 P/R)	List Price
PKP213D05A-R2EL	€94.00	-	-
PKP214D06A-R2EL	€97.00	-	-
PKP223D15A2-R2EL	€80.00	-	-
PKP225D15A2-R2EL	€86.00	-	-
PKP233D15A-R2EL	€80.00	-	-
PKP235D15A-R2EL	€86.00	-	-
PKP243D15A2-R2EL	€80.00	PKP243D15A2-R2FL	€80.00
PKP243D23A2-R2EL	€80.00	PKP243D23A2-R2FL	€80.00
PKP244D15A2-R2EL	€82.00	PKP244D15A2-R2FL	€82.00
PKP244D23A2-R2EL	€82.00	PKP244D23A2-R2FL	€82.00
PKP245D15A2-R2EL	€86.00	PKP245D15A2-R2FL	€86.00
PKP245D23A2-R2EL	€86.00	PKP245D23A2-R2FL	€86.00
PKP246D15A2-R2EL	€88.00	PKP246D15A2-R2FL	€88.00
PKP246D23A2-R2EL	€88.00	PKP246D23A2-R2FL	€88.00
PKP264D14A2-R2EL	€88.00	PKP264D14A2-R2FL	€88.00
PKP264D28A2-R2EL	€88.00	PKP264D28A2-R2FL	€88.00
PKP264D42A2-R2EL	€88.00	PKP264D42A2-R2FL	€88.00
PKP266D14A2-R2EL	€92.00	PKP266D14A2-R2FL	€92.00
PKP266D28A2-R2EL	€92.00	PKP266D28A2-R2FL	€92.00
PKP266D42A2-R2EL	€92.00	PKP266D42A2-R2FL	€92.00
PKP268D14A2-R2EL	€102.00	PKP268D14A2-R2FL	€102.00
PKP268D28A2-R2EL	€102.00	PKP268D28A2-R2FL	€102.00
PKP268D42A2-R2EL	€102.00	PKP268D42A2-R2FL	€102.00

##### ● Unipolar (5 or 6 Lead Wires)

Product Name (Single Shaft)	List Price	Product Name (Double Shaft)	List Price
PKP213U05A	€44.00	PKP213U05B	€46.00
PKP214U06A	€47.00	PKP214U06B	€49.00
PKP223U09A2	€30.00	PKP223U09B2	€32.00
PKP225U09A2	€36.00	PKP225U09B2	€38.00
PKP233U12A	€30.00	PKP233U12B	€32.00
PKP235U12A	€36.00	PKP235U12B	€38.00
PKP243U09A2	€30.00	PKP243U09B2	€32.00
PKP244U12A2	€32.00	PKP244U12B2	€34.00
PKP245U12A2	€36.00	PKP245U12B2	€38.00
PKP246U12A2	€38.00	PKP246U12B2	€40.00
PK256-02A	€57.00	PK256-02B	€59.00
PK258-02A	€63.00	PK258-02B	€65.00
PKP264U10A2	€38.00	PKP264U10B2	€40.00
PKP264U20A2	€38.00	PKP264U20B2	€40.00
PKP266U10A2	€42.00	PKP266U10B2	€44.00
PKP266U20A2	€42.00	PKP266U20B2	€44.00
PKP268U10A2	€52.00	PKP268U10B2	€54.00
PKP268U20A2	€52.00	PKP268U20B2	€54.00
PK264JA	€74.00	PK264JB	€77.00
PK266JA	€81.00	PK266JB	€84.00
PK267JA	€96.00	PK267JB	€99.00
PK269JA	€120.00	PK269JB	€124.00
PKP296U20A	€89.00	PKP296U20B	€96.00
PKP296U30A	€89.00	PKP296U30B	€96.00
PKP296U45A	€89.00	PKP296U45B	€96.00
PKP299U20A	€137.00	PKP299U20B	€144.00
PKP299U30A	€137.00	PKP299U30B	€144.00
PKP299U45A	€137.00	PKP299U45B	€144.00
PKP2913U20A	€173.00	PKP2913U20B	€180.00
PKP2913U40A	€173.00	PKP2913U40B	€180.00

##### ● Unipolar (5 or 6 Lead Wires)

Product Name (Encoder Resolution: 200 P/R)	List Price	Product Name (Encoder Resolution: 400 P/R)	List Price
PKP213U05A-R2EL	€94.00	-	-
PKP214U06A-R2EL	€97.00	-	-
PKP223U09A2-R2EL	€80.00	-	-
PKP225U09A2-R2EL	€86.00	-	-
PKP233U12A-R2EL	€80.00	-	-
PKP235U12A-R2EL	€86.00	-	-
PKP243U09A2-R2EL	€80.00	PKP243U09A2-R2FL	€80.00
PKP244U12A2-R2EL	€82.00	PKP244U12A2-R2FL	€82.00
PKP245U12A2-R2EL	€86.00	PKP245U12A2-R2FL	€86.00
PKP246U12A2-R2EL	€88.00	PKP246U12A2-R2FL	€88.00
PKP264U10A2-R2EL	€88.00	PKP264U10A2-R2FL	€88.00
PKP264U20A2-R2EL	€88.00	PKP264U20A2-R2FL	€88.00
PKP266U10A2-R2EL	€92.00	PKP266U10A2-R2FL	€92.00
PKP266U20A2-R2EL	€92.00	PKP266U20A2-R2FL	€92.00
PKP268U10A2-R2EL	€102.00	PKP268U10A2-R2FL	€102.00
PKP268U20A2-R2EL	€102.00	PKP268U20A2-R2FL	€102.00

## ◇ Standard Type with Electromagnetic Brake

## • Bipolar (4 Lead Wires)

Product Name	List Price
<b>PKP223D15M2</b>	€90.00
<b>PKP225D15M2</b>	€96.00
<b>PKP233D15M</b>	€115.00
<b>PKP235D15M</b>	€121.00
<b>PKP243D15M</b>	€115.00
<b>PKP244D15M</b>	€117.00
<b>PKP245D15M</b>	€121.00
<b>PKP246D15M</b>	€123.00
<b>PKP264D28M</b>	€133.00
<b>PKP266D28M</b>	€137.00
<b>PKP268D28M</b>	€147.00

## ◇ High-Resolution Type

## • Bipolar (4 Lead Wires)

Product Name (Single Shaft)	List Price	Product Name (Double Shaft)	List Price
<b>PKP243MD15A</b>	€30.00	<b>PKP243MD15B</b>	€32.00
<b>PKP244MD15A</b>	€32.00	<b>PKP244MD15B</b>	€34.00
<b>PKP264MD28A</b>	€38.00	<b>PKP264MD28B</b>	€40.00
<b>PKP266MD28A</b>	€42.00	<b>PKP266MD28B</b>	€44.00
<b>PKP268MD28A</b>	€52.00	<b>PKP268MD28B</b>	€54.00

## ◇ High-Resolution Type with Encoder

## • Bipolar (4 Lead Wires)

Product Name (Encoder Resolution: 400 P/R)	List Price
<b>PKP243MD15A-R2FL</b>	€80.00
<b>PKP244MD15A-R2FL</b>	€82.00
<b>PKP264MD28A-R2FL</b>	€88.00
<b>PKP266MD28A-R2FL</b>	€92.00
<b>PKP268MD28A-R2FL</b>	€102.00

## ◇ High-Resolution Type with Electromagnetic Brake

## • Bipolar (4 Lead Wires)

Product Name	List Price
<b>PKP243MD15M</b>	€115.00
<b>PKP244MD15M</b>	€117.00
<b>PKP264MD28M</b>	€133.00
<b>PKP266MD28M</b>	€137.00
<b>PKP268MD28M</b>	€147.00

## ◇ Flat Type

## • Bipolar (4 Lead Wires)

Product Name (Single Shaft)	List Price
<b>PKP262FD15AW</b>	€46.00

## ◇ Flat Type with Harmonic Gears

## • Bipolar (4 Lead Wires)

Product Name (Single Shaft)	List Price
<b>PKP262FD15AW-H50</b>	€685.00
<b>PKP262FD15AW-H100</b>	€685.00

## • Unipolar (6 Lead Wires)

Product Name	List Price
<b>PKP223U09M2</b>	€90.00
<b>PKP225U09M2</b>	€96.00
<b>PKP233U12M</b>	€115.00
<b>PKP235U12M</b>	€121.00
<b>PKP243U09M</b>	€115.00
<b>PKP244U12M</b>	€117.00
<b>PKP245U12M</b>	€121.00
<b>PKP246U12M</b>	€123.00
<b>PKP264U20M</b>	€133.00
<b>PKP266U20M</b>	€137.00
<b>PKP268U20M</b>	€147.00

## • Unipolar (6 Lead Wires)

Product Name (Single Shaft)	List Price	Product Name (Double Shaft)	List Price
<b>PKP243MU09A</b>	€30.00	<b>PKP243MU09B</b>	€32.00
<b>PKP244MU12A</b>	€32.00	<b>PKP244MU12B</b>	€34.00
<b>PKP264MU20A</b>	€38.00	<b>PKP264MU20B</b>	€40.00
<b>PKP266MU20A</b>	€42.00	<b>PKP266MU20B</b>	€44.00
<b>PKP268MU20A</b>	€52.00	<b>PKP268MU20B</b>	€54.00

## • Unipolar (6 Lead Wires)

Product Name (Encoder Resolution: 400 P/R)	List Price
<b>PKP243MU09A-R2FL</b>	€80.00
<b>PKP244MU12A-R2FL</b>	€82.00
<b>PKP264MU20A-R2FL</b>	€88.00
<b>PKP266MU20A-R2FL</b>	€92.00
<b>PKP268MU20A-R2FL</b>	€102.00

## • Unipolar (6 Lead Wires)

Product Name	List Price
<b>PKP243MU09M</b>	€115.00
<b>PKP244MU12M</b>	€117.00
<b>PKP264MU20M</b>	€133.00
<b>PKP266MU20M</b>	€137.00
<b>PKP268MU20M</b>	€147.00

Overview,  
Product  
SeriesAC Input  
Motor &  
Driver0.36°/Geared  
**α<sub>STEP</sub>**  
Absolute  
**AZ**0.36°/Geared  
**α<sub>STEP</sub>**  
**AR**0.72°/Geared  
**RKII**DC Input  
Motor &  
Driver0.36°/Geared  
**α<sub>STEP</sub>**  
Absolute  
**AZ**0.36°/Geared  
**α<sub>STEP</sub>**  
**AR**1.8°/0.72°  
/0.36°  
**CVK**0.72°/0.36°  
/Geared  
**CRK**1.8°/Geared  
**RBK**Motor Only  
/Driver Only1.8°/0.9°  
**PKP/PK**Geared  
**PKP/PK**0.72°/0.36°  
**PKP/PK**

Driver

Accessories

◇ **SH** Geared Type

## ● Bipolar (4 Lead Wires)

Product Name (Single Shaft)	List Price	Product Name (Double Shaft)	List Price
PKP223D15A-SG7.2	€90.00	PKP223D15B-SG7.2	€92.00
PKP223D15A-SG9	€90.00	PKP223D15B-SG9	€92.00
PKP223D15A-SG10	€90.00	PKP223D15B-SG10	€92.00
PKP223D15A-SG18	€105.00	PKP223D15B-SG18	€107.00
PKP223D15A-SG36	€105.00	PKP223D15B-SG36	€107.00
PKP243D15A2-SG3.6	€90.00	PKP243D15B2-SG3.6	€92.00
PKP243D23A2-SG3.6	€90.00	PKP243D23B2-SG3.6	€92.00
PKP243D15A2-SG7.2	€90.00	PKP243D15B2-SG7.2	€92.00
PKP243D23A2-SG7.2	€90.00	PKP243D23B2-SG7.2	€92.00
PKP243D15A2-SG9	€90.00	PKP243D15B2-SG9	€92.00
PKP243D23A2-SG9	€90.00	PKP243D23B2-SG9	€92.00
PKP243D15A2-SG10	€90.00	PKP243D15B2-SG10	€92.00
PKP243D23A2-SG10	€90.00	PKP243D23B2-SG10	€92.00
PKP243D15A2-SG18	€105.00	PKP243D15B2-SG18	€107.00
PKP243D23A2-SG18	€105.00	PKP243D23B2-SG18	€107.00
PKP243D15A2-SG36	€105.00	PKP243D15B2-SG36	€107.00
PKP243D23A2-SG36	€105.00	PKP243D23B2-SG36	€107.00
PKP264D14A2-SG3.6	€108.00	PKP264D14B2-SG3.6	€110.00
PKP264D28A2-SG3.6	€108.00	PKP264D28B2-SG3.6	€110.00
PKP264D14A2-SG7.2	€108.00	PKP264D14B2-SG7.2	€110.00
PKP264D28A2-SG7.2	€108.00	PKP264D28B2-SG7.2	€110.00
PKP264D14A2-SG9	€108.00	PKP264D14B2-SG9	€110.00
PKP264D28A2-SG9	€108.00	PKP264D28B2-SG9	€110.00
PKP264D14A2-SG10	€108.00	PKP264D14B2-SG10	€110.00
PKP264D28A2-SG10	€108.00	PKP264D28B2-SG10	€110.00
PKP264D14A2-SG18	€118.00	PKP264D14B2-SG18	€120.00
PKP264D28A2-SG18	€118.00	PKP264D28B2-SG18	€120.00
PKP264D14A2-SG36	€118.00	PKP264D14B2-SG36	€120.00
PKP264D28A2-SG36	€118.00	PKP264D28B2-SG36	€120.00

## ● Unipolar (5 or 6 Lead Wires)

Product Name (Single Shaft)	List Price	Product Name (Double Shaft)	List Price
PKP223U09A-SG7.2	€90.00	PKP223U09B-SG7.2	€92.00
PKP223U09A-SG9	€90.00	PKP223U09B-SG9	€92.00
PKP223U09A-SG10	€90.00	PKP223U09B-SG10	€92.00
PKP223U09A-SG18	€105.00	PKP223U09B-SG18	€107.00
PKP223U09A-SG36	€105.00	PKP223U09B-SG36	€107.00
PKP243U09A2-SG3.6	€90.00	PKP243U09B2-SG3.6	€92.00
PKP243U09A2-SG7.2	€90.00	PKP243U09B2-SG7.2	€92.00
PKP243U09A2-SG9	€90.00	PKP243U09B2-SG9	€92.00
PKP243U09A2-SG10	€90.00	PKP243U09B2-SG10	€92.00
PKP243U09A2-SG18	€105.00	PKP243U09B2-SG18	€107.00
PKP243U09A2-SG36	€105.00	PKP243U09B2-SG36	€107.00
PKP264U10A2-SG3.6	€108.00	PKP264U10B2-SG3.6	€110.00
PKP264U20A2-SG3.6	€108.00	PKP264U20B2-SG3.6	€110.00
PKP264U10A2-SG7.2	€108.00	PKP264U10B2-SG7.2	€110.00
PKP264U20A2-SG7.2	€108.00	PKP264U20B2-SG7.2	€110.00
PKP264U10A2-SG9	€108.00	PKP264U10B2-SG9	€110.00
PKP264U20A2-SG9	€108.00	PKP264U20B2-SG9	€110.00
PKP264U10A2-SG10	€108.00	PKP264U10B2-SG10	€110.00
PKP264U20A2-SG10	€108.00	PKP264U20B2-SG10	€110.00
PKP264U10A2-SG18	€118.00	PKP264U10B2-SG18	€120.00
PKP264U20A2-SG18	€118.00	PKP264U20B2-SG18	€120.00
PKP264U10A2-SG36	€118.00	PKP264U10B2-SG36	€120.00
PKP264U20A2-SG36	€118.00	PKP264U20B2-SG36	€120.00

## ● Bipolar/Unipolar (8 Lead wires)

Product Name (Single Shaft)	List Price	Product Name (Double Shaft)	List Price
PK296AE-SG3.6	€212.00	PK296BE-SG3.6	€216.00
PK296AE-SG7.2	€212.00	PK296BE-SG7.2	€216.00
PK296AE-SG9	€212.00	PK296BE-SG9	€216.00
PK296AE-SG10	€212.00	PK296BE-SG10	€216.00
PK296AE-SG18	€212.00	PK296BE-SG18	€216.00
PK296AE-SG36	€221.00	PK296BE-SG36	€225.00

## ● Connection Cable

## ◇ Motor Cable (For bipolar)

Product Name	Length L (m)	List Price
LC2B06A	0.6	€5.00
LC2B06B	0.6	€5.00
LC2B06C	0.6	€5.00
LC2B06E	0.6	€5.00

## ◇ Encoder Type (Line driver output)

Product Name	Length L (m)	List Price
LCE08A-006	0.6	€10.00

## ◇ Motor Cable (For unipolar)

Product Name	Length L (m)	List Price
LC2U06A	0.6	€5.00
LC2U10A	1	€7.00
LC2U06B	0.6	€5.00
LC2U10B	1	€7.00
LC2U06C	0.6	€5.00
LC2U10C	1	€8.00
LC2U06E	0.6	€5.00

## ■ Included

Type	Motor Installation Screw	Parallel Key	Varistor	Operating Manual
Standard Type				
High-Resolution Type	–	–	–	1 Set
Flat Type				
Type with an Electromagnetic Brake	–	–	1 Piece	1 Set
<b>SH</b> Geared Type	Frame Size 28 mm	–	–	1 Set
	Frame Size 42 mm	–	–	1 Set
	Frame Size 60 mm	–	–	1 Set
	Frame Size 90 mm	M6×18 P1.0 (4 Screws)	1 Piece	–

## Product Line (Products on the WEB)

### Motor

#### Standard Type with Cabtire Cable

Product Name (Single Shaft)	List Price
<b>PK264DW</b>	€85.00
<b>PK266DW</b>	€90.00
<b>PK268DW</b>	€106.00
<b>PK296DW</b>	€139.00
<b>PK299DW</b>	€195.00
<b>PK2913DW</b>	€272.00

#### Standard Type with Terminal Box

Product Name (Single Shaft)	List Price
<b>PK264DAT</b>	€129.00
<b>PK264D1T</b>	€129.00
<b>PK266DAT</b>	€134.00
<b>PK266D1T</b>	€134.00
<b>PK268DAT</b>	€149.00
<b>PK268D1T</b>	€149.00
<b>PK296DT</b>	€187.00
<b>PK296EAT</b>	€187.00
<b>PK299DT</b>	€239.00
<b>PK299EAT</b>	€239.00
<b>PK2913DT</b>	€310.00
<b>PK2913EAT</b>	€310.00

#### TH Geared Type

##### Bipolar (4 Lead Wires)

Product Name (Single Shaft)	List Price	Product Name (Double Shaft)	List Price
<b>PK243DA-T3.6</b>	€160.00	<b>PK243DB-T3.6</b>	€162.00
<b>PK243DA-T7.2</b>	€160.00	<b>PK243DB-T7.2</b>	€162.00
<b>PK243DA-T10</b>	€173.00	<b>PK243DB-T10</b>	€174.00
<b>PK243DA-T20</b>	€173.00	<b>PK243DB-T20</b>	€174.00
<b>PK243DA-T30</b>	€173.00	<b>PK243DB-T30</b>	€174.00
<b>PK264DA-T3.6</b>	€184.00	<b>PK264DB-T3.6</b>	€186.00
<b>PK264DA-T7.2</b>	€184.00	<b>PK264DB-T7.2</b>	€186.00
<b>PK264DA-T10</b>	€197.00	<b>PK264DB-T10</b>	€199.00
<b>PK264DA-T20</b>	€197.00	<b>PK264DB-T20</b>	€199.00
<b>PK264DA-T30</b>	€197.00	<b>PK264DB-T30</b>	€199.00

##### Bipolar/Unipolar (6 Lead wires)

Product Name (Single Shaft)	List Price	Product Name (Double Shaft)	List Price
<b>PK243A1-T3.6</b>	€160.00	<b>PK243B1-T3.6</b>	€162.00
<b>PK243A1-T7.2</b>	€160.00	<b>PK243B1-T7.2</b>	€162.00
<b>PK243A1-T10</b>	€173.00	<b>PK243B1-T10</b>	€175.00
<b>PK243A1-T20</b>	€173.00	<b>PK243B1-T20</b>	€175.00
<b>PK243A1-T30</b>	€173.00	<b>PK243B1-T30</b>	€175.00
<b>PK264A2-T3.6</b>	€184.00	<b>PK264B2-T3.6</b>	€186.00
<b>PK264A2-T7.2</b>	€184.00	<b>PK264B2-T7.2</b>	€186.00
<b>PK264A2-T10</b>	€197.00	<b>PK264B2-T10</b>	€199.00
<b>PK264A2-T20</b>	€197.00	<b>PK264B2-T20</b>	€199.00
<b>PK264A2-T30</b>	€197.00	<b>PK264B2-T30</b>	€199.00

#### PS Geared Type

##### Bipolar (4 Lead Wires)

Product Name (Single Shaft)	List Price	Product Name (Double Shaft)	List Price
<b>PK223PDA-PS5</b>	€317.00	<b>PK223PDB-PS5</b>	€319.00
<b>PK223PDA-PS10</b>	€317.00	<b>PK223PDB-PS10</b>	€319.00

The following items are included in each product.

Motor, Operating Manual

Overview,  
Product  
Series

AC Input  
Motor &  
Driver

0.36°/Geared  
**αSTEP**  
Absolute  
**AZ**

0.36°/Geared  
**αSTEP**  
**AR**

0.72°/Geared  
**RKII**

DC Input  
Motor &  
Driver

0.36°/Geared  
**αSTEP**  
Absolute  
**AZ**

0.36°/Geared  
**αSTEP**  
**AR**

1.8°/0.72°  
/0.36°  
**CVK**

0.72°/0.36°  
/Geared  
**CRK**

1.8°/Geared  
**RBK**

Motor Only  
/Driver Only

1.8°/0.9°  
**PKP/PK**

Geared  
**PKP/PK**

0.72°/0.36°  
**PKP/PK**

Driver

Accessories



For details (specifications, characteristics, dimensions and others) on these products please refer to our website or contact your nearest Oriental Motor sales office.

[www.orientalmotor.eu](http://www.orientalmotor.eu)



## Standard Type Frame Size 20 mm (Unipolar 5 lead wires)

### Specifications

Product Name	Maximum Holding Torque N·m	Rotor Inertia J: kg·m <sup>2</sup>	Rated Current A/Phase	Voltage VDC	Winding Resistance Ω/Phase	Inductance mH/Phase	Basic Step Angle	Recommended Driver Product Name*
PKP213U05□	0.014	$1.6 \times 10^{-7}$	0.5	4.25	8.5	2.9	1.8°	CMD2109P
PKP214U06□	0.026	$2.9 \times 10^{-7}$	0.6	4.2	7	2.4		

● Either **A** (Single Shaft) or **B** (Double Shaft) indicating the configuration is specified where the box □ is located in the product name.

\*Refer to page A-445 for details on the recommended driver.

### Speed – Torque Characteristics (Reference values)

PKP213U05A/PKP213U05B

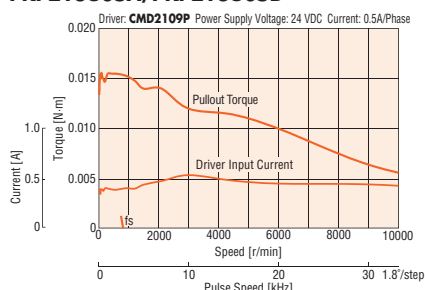

PKP214U06A/PKP214U06B

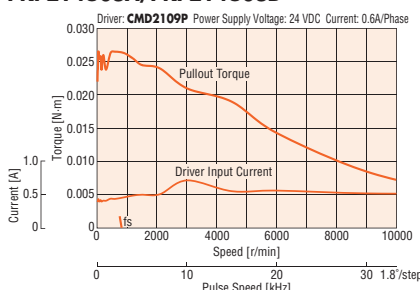

**Note**

- Data for the speed – torque characteristics is based on Oriental Motor's internal measurement conditions. If the conditions are changed, the characteristics may also change as a result.
- Depending on the driving conditions, a considerable amount of heat may be generated by the motor. Be sure to keep the motor case temperature at 100°C or less.

### Dimensions (Unit = mm)

● Motor

Product Name	L1	L2	Mass kg
PKP213U05A	30	—	0.05
PKP213U05B		38	
PKP214U06A	40	—	0.07
PKP214U06B		48	

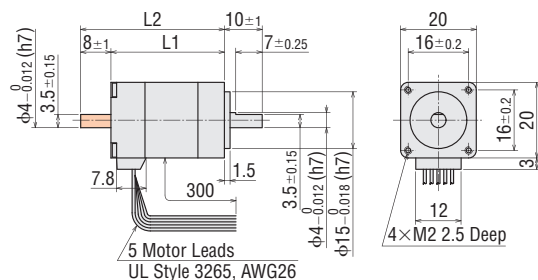

- These dimensions are for double shaft motors.  
For single shaft motors, ignore the shaded areas.
- Back shaft of double shaft products have a flat the whole length.

### Inner Wiring Diagram of Motor

Wiring Diagram No.: ⑤

- Refer to page A-431 for inner wiring diagram of motor.

Overview,  
Product  
Series

AC Input  
Motor &  
Driver

0.36°/Geared  
αSTEP  
Absolute  
AZ

0.36°/Geared  
αSTEP  
AR

0.72°/Geared  
RK II

DC Input  
Motor &  
Driver

0.36°/Geared  
αSTEP  
Absolute  
AZ

0.36°/Geared  
αSTEP  
AR

1.8°/0.72°  
/0.36°  
CVK

0.72°/0.36°  
/Geared  
CRK

1.8°/Geared  
RBK

Motor Only  
/Driver Only

1.8°/0.9°  
PKP/PK

Geared  
PKP/PK

0.72°/0.36°  
PKP/PK

Driver

Accessories

# Standard Type with Encoder Frame Size 20 mm (Bipolar 4 lead wires)

## Specifications

Product Name	Maximum Holding Torque N·m	Rotor Inertia J: kg·m <sup>2</sup>	Rated Current A/Phase	Voltage VDC	Winding Resistance Ω/Phase	Inductance mH/Phase	Basic Step Angle	Recommended Driver Product Name*
<b>PKP213D05A-R2EL</b>	0.02	$1.66 \times 10^{-7}$	0.5	4.25	8.5	4.1	1.8°	<b>CVD205BR-K</b>
<b>PKP214D06A-R2EL</b>	0.036	$2.96 \times 10^{-7}$	0.6	3.9	6.5	3.5		<b>CVD206BR-K</b>

● Refer to page A-430 for encoder specifications.

\*Refer to page A-439 for details on the recommended driver.

## Speed – Torque Characteristics (Reference values)

**PKP213D05A-R2EL**

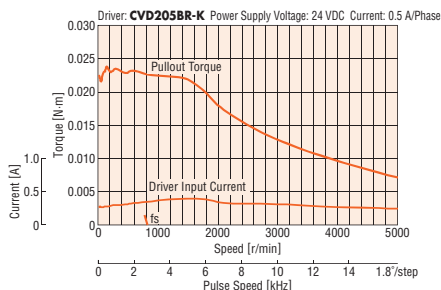

**PKP214D06A-R2EL**

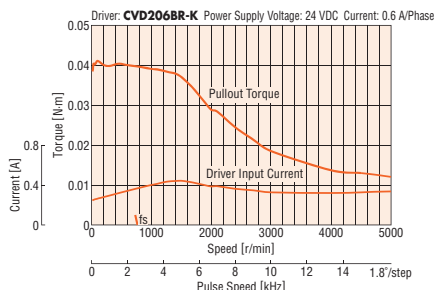

**Note**

- Data for the speed – torque characteristics is based on Oriental Motor's internal measurement conditions. If the conditions are changed, the characteristics may also change as a result.
- Depending on the driving conditions, a considerable amount of heat may be generated by the motor. To protect the encoder, be sure to keep the motor case temperature at 85°C max.

## Dimensions (Unit = mm)

### Motor

Product Name	L	Mass kg
<b>PKP213D05A-R2EL</b>	46.5	0.06
<b>PKP214D06A-R2EL</b>	56.5	0.08

● Applicable Connector (Molex)

	Encoder
Connector Housing	51021-0800
Contact	50079-8100
Crimp Tool	57067-3000

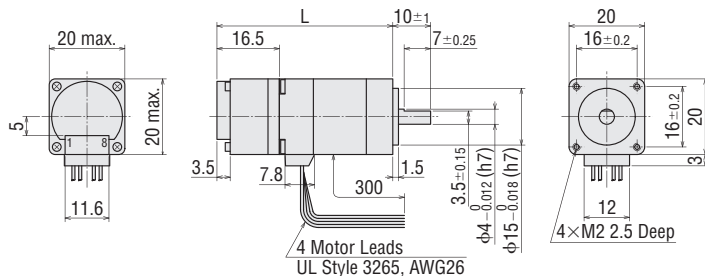

### Connection Cable (Sold separately)

#### For Encoder

Product Name	Length L (m)
<b>LCE08A-006</b>	0.6

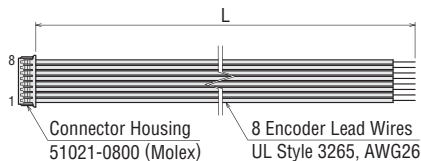

## Inner Wiring Diagram of Motor

Wiring Diagram No.: ③

● Refer to page A-431 for inner wiring diagram of motor.



## Standard Type with Encoder Frame Size 20 mm (Unipolar 5 lead wires)

### Specifications

Product Name	Maximum Holding Torque N·m	Rotor Inertia J: kg·m <sup>2</sup>	Rated Current A/Phase	Voltage VDC	Winding Resistance Ω/Phase	Inductance mH/Phase	Basic Step Angle	Recommended Driver Product Name*
<b>PKP213U05A-R2EL</b>	0.014	$1.66 \times 10^{-7}$	0.5	4.25	8.5	2.9	1.8°	<b>CMD2109P</b>
<b>PKP214U06A-R2EL</b>	0.026	$2.96 \times 10^{-7}$	0.6	4.2	7	2.4		

● Refer to page A-430 for encoder specifications.

\*Refer to page A-445 for details on the recommended driver.

### Speed – Torque Characteristics (Reference values)

**PKP213U05A-R2EL**

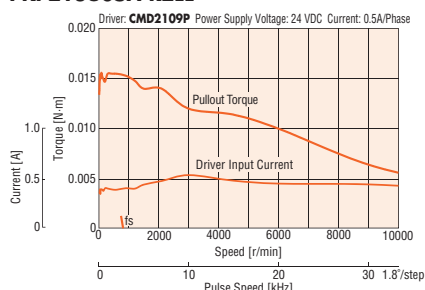

**PKP214U06A-R2EL**

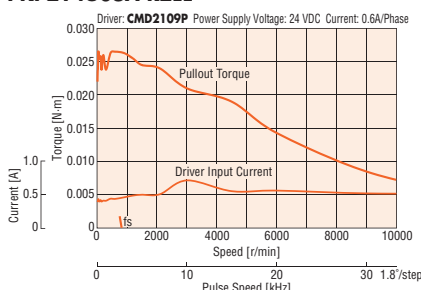

**Note**

- Data for the speed – torque characteristics is based on Oriental Motor's internal measurement conditions. If the conditions are changed, the characteristics may also change as a result.
- Depending on the driving conditions, a considerable amount of heat may be generated by the motor. To protect the encoder, be sure to keep the motor case temperature at 85°C max.

### Dimensions (Unit = mm)

● Motor

Product Name	L	Mass kg
<b>PKP213U05A-R2EL</b>	46.5	0.06
<b>PKP214U06A-R2EL</b>	56.5	0.08

● Applicable Connector (Molex)

	Encoder
Connector Housing	51021-0800
Contact	50079-8100
Crimp Tool	57067-3000

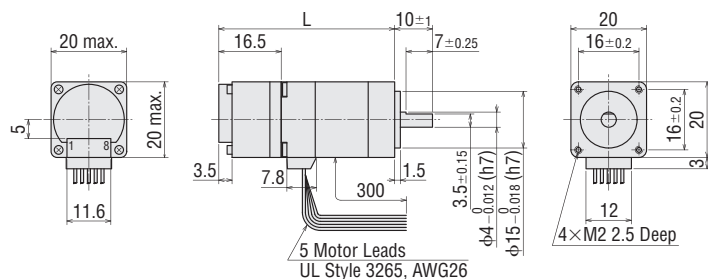

● Connection Cable (Sold separately)

◇ For Encoder

Product Name	Length L (m)
<b>LCE08A-006</b>	0.6

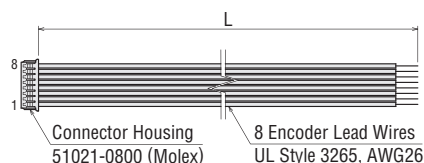

### Inner Wiring Diagram of Motor

Wiring Diagram No.: ⑤

● Refer to page A-431 for inner wiring diagram of motor.

Overview, Product Series

AC Input Motor & Driver

0.36°/Geared  
αSTEP Absolute AZ

0.36°/Geared  
αSTEP AR

0.72°/Geared  
RK II

DC Input Motor & Driver

0.36°/Geared  
αSTEP Absolute AZ

0.36°/Geared  
αSTEP AR

1.8°/0.72°/0.36°  
CVK

0.72°/0.36°/Geared  
CRK

1.8°/Geared  
RBK

Motor Only / Driver Only

1.8°/0.9°  
PKP/PK

Geared  
PKP/PK

0.72°/0.36°  
PKP/PK

Driver

Accessories

# Standard Type Frame Size 28 mm (Bipolar 4 lead wires)

## Specifications

Product Name	Maximum Holding Torque N·m	Rotor Inertia J: kg·m <sup>2</sup>	Rated Current A/Phase	Voltage VDC	Winding Resistance Ω/Phase	Inductance mH/Phase	Basic Step Angle	Recommended Driver Product Name*
<b>PKP223D15□2</b>	0.095	$9 \times 10^{-7}$	1.5	1.77	1.18	0.96	1.8°	<b>CVD215BR-K</b>
<b>PKP225D15□2</b>	0.19	$18 \times 10^{-7}$		3	2	1.6		

● Either **A** (Single Shaft) or **B** (Double Shaft) indicating the configuration is specified where the box □ is located in the product name.  
\*Refer to page A-439 for details on the recommended driver.

## Speed – Torque Characteristics (Reference values)

**PKP223D15A2/PKP223D15B2**

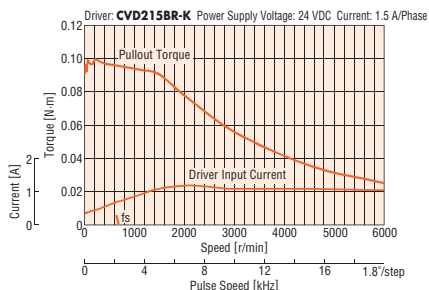

**PKP225D15A2/PKP225D15B2**

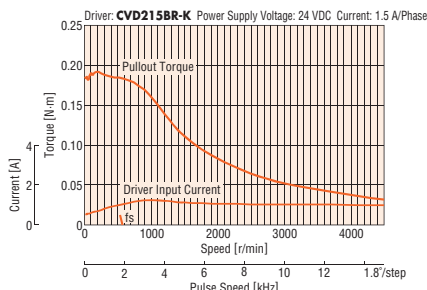

**Note**

- Data for the speed – torque characteristics is based on Oriental Motor's internal measurement conditions. If the conditions are changed, the characteristics may also change as a result.
- Depending on the driving conditions, a considerable amount of heat may be generated by the motor. Be sure to keep the motor case temperature at 100°C or less.

## Dimensions (Unit = mm)

● Motor

Product Name	L1	L2	Mass kg
<b>PKP223D15A2</b>	32	–	0.11
<b>PKP223D15B2</b>		42	
<b>PKP225D15A2</b>	51.5	–	0.2
<b>PKP225D15B2</b>		61.5	

● Applicable Connector

Connector Housing: 51065-0600 (Molex)  
Contact: 50212-8100 (Molex)  
Crimp Tool: 57176-5000 (Molex)

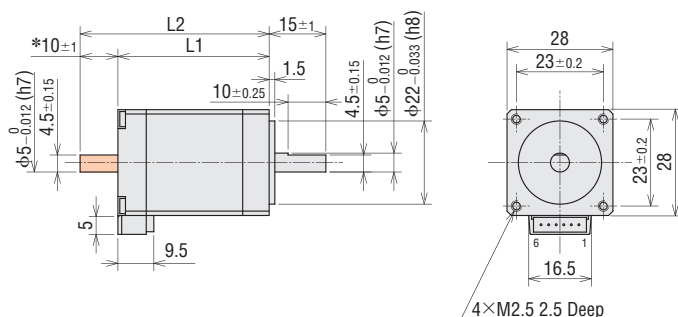

\*The length of the shaft flat on the double shaft model is 10±0.25.  
● These dimensions are for double shaft motors.  
For single shaft motors, ignore the shaded areas.

● Connection Cable (Sold separately)

◇ For Motor

Product Name	Length L (m)
<b>LC2B06A</b>	0.6

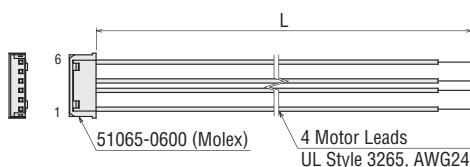

## Inner Wiring Diagram of Motor

Wiring Diagram No.: ②

● Refer to page A-431 for inner wiring diagram of motor.

## Standard Type Frame Size 28 mm (Unipolar 6 lead wires)

### Specifications

Product Name	Maximum Holding Torque N·m	Rotor Inertia J: kg·m <sup>2</sup>	Rated Current A/Phase	Voltage VDC	Winding Resistance Ω/Phase	Inductance mH/Phase	Basic Step Angle	Recommended Driver Product Name*
<b>PKP223U09</b> □ <b>2</b>	0.075	$9 \times 10^{-7}$	0.95	2.95	3.11	1.44	1.8°	<b>CMD2109P</b>
<b>PKP225U09</b> □ <b>2</b>	0.135	$18 \times 10^{-7}$		4.4	4.6	2.11		

● Either **A** (Single Shaft) or **B** (Double Shaft) indicating the configuration is specified where the box □ is located in the product name.

\*Refer to page A-445 for details on the recommended driver.

### Speed – Torque Characteristics (Reference values)

**PKP223U09A2/PKP223U09B2**

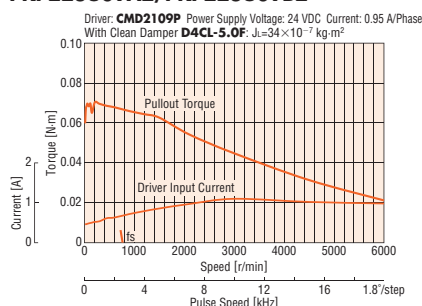

**PKP225U09A2/PKP225U09B2**

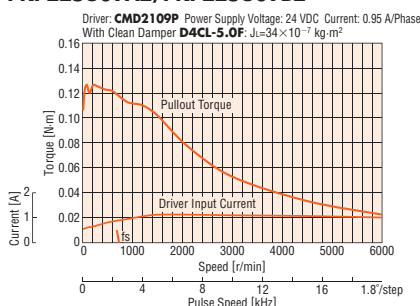

#### Note

- Data for the speed – torque characteristics is based on Oriental Motor's internal measurement conditions. If the conditions are changed, the characteristics may also change as a result.
- If there is a "clean damper" entry in the speed - torque characteristics, the data is for a double shaft motor when a clean damper is equipped.
- Depending on the driving conditions, a considerable amount of heat may be generated by the motor. Be sure to keep the motor case temperature at 100°C or less.

### Dimensions (Unit = mm)

#### Motor

Product Name	L1	L2	Mass kg
<b>PKP223U09A2</b>	32	–	0.11
<b>PKP223U09B2</b>		42	
<b>PKP225U09A2</b>	51.5	–	0.2
<b>PKP225U09B2</b>		61.5	

- Applicable Connector  
Connector Housing: 51065-0600 (Molex)  
Contact: 50212-8100 (Molex)  
Crimp Tool: 57176-5000 (Molex)

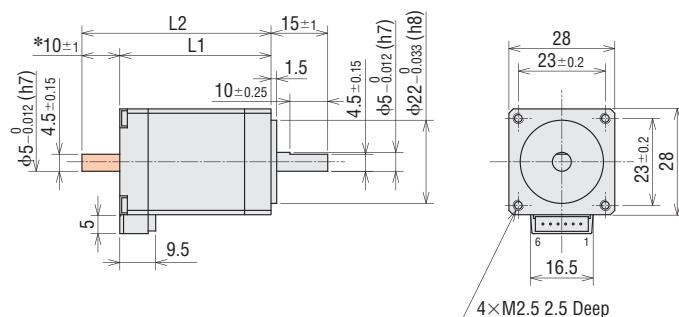

\*The length of the shaft flat on the double shaft model is 10±0.25.

- These dimensions are for double shaft motors.  
For single shaft motors, ignore the shaded areas.

#### Connection Cable (Sold separately)

##### ◇ For Motor

Product Name	Length L (m)
<b>LC2U06A</b>	0.6
<b>LC2U10A</b>	1

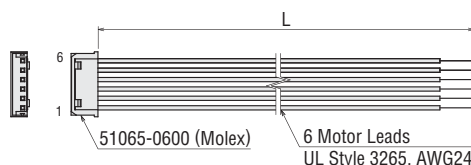

### Inner Wiring Diagram of Motor

Wiring Diagram No.: ⑥

- Refer to page A-431 for inner wiring diagram of motor.

Overview,  
Product  
Series

AC Input  
Motor &  
Driver

0.36°/Geared  
**αSTEP**  
Absolute  
**AZ**

0.36°/Geared  
**αSTEP**  
**AR**

0.72°/Geared  
**RKII**

DC Input  
Motor &  
Driver

0.36°/Geared  
**αSTEP**  
Absolute  
**AZ**

0.36°/Geared  
**αSTEP**  
**AR**

1.8°/0.72°  
/0.36°  
**CVK**

0.72°/0.36°  
/Geared  
**CRK**

1.8°/Geared  
**RBK**

Motor Only  
/Driver Only

1.8°/0.9°  
**PKP/PK**

Geared  
**PKP/PK**

0.72°/0.36°  
**PKP/PK**

Driver

Accessories

# Standard Type with Encoder Frame Size 28 mm (Bipolar 4 lead wires)

## Specifications

Product Name	Maximum Holding Torque N-m	Rotor Inertia J: kg-m <sup>2</sup>	Rated Current A/Phase	Voltage VDC	Winding Resistance Ω/Phase	Inductance mH/Phase	Basic Step Angle	Recommended Driver Product Name*
<b>PKP223D15A2-R2EL</b>	0.095	$9 \times 10^{-7}$	1.5	1.77	1.18	0.96	1.8°	<b>CVD215BR-K</b>
<b>PKP225D15A2-R2EL</b>	0.19	$18 \times 10^{-7}$		3	2	1.6		

● Refer to page A-430 for encoder specifications.

\*Refer to page A-439 for details on the recommended driver.

## Speed – Torque Characteristics (Reference values)

**PKP223D15A2-R2EL**

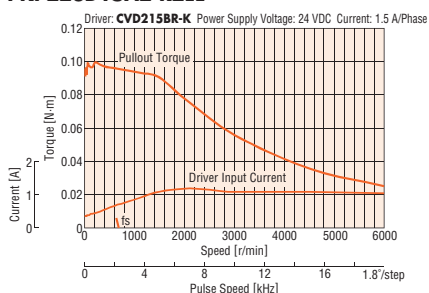

**PKP225D15A2-R2EL**

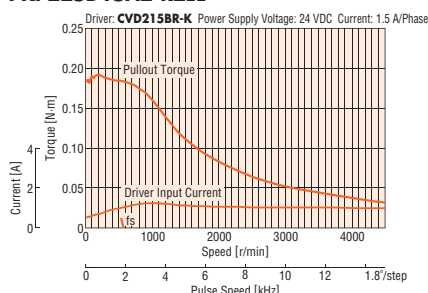

### Note

- Data for the speed – torque characteristics is based on Oriental Motor's internal measurement conditions. If the conditions are changed, the characteristics may also change as a result.
- Depending on the driving conditions, a considerable amount of heat may be generated by the motor. To protect the encoder, be sure to keep the motor case temperature at 85°C max.

## Dimensions (Unit = mm)

### Motor

Product Name	L	Mass kg
<b>PKP223D15A2-R2EL</b>	47.5	0.12
<b>PKP225D15A2-R2EL</b>	67	0.21

● Applicable Connector (Molex)

	Motor	Encoder
Connector Housing	51065-0600	51021-0800
Contact	50212-8100	50079-8100
Crimp Tool	57176-5000	57067-3000

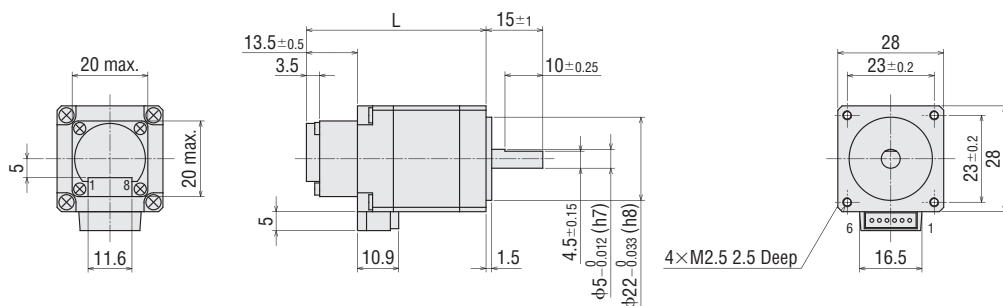

### Connection Cable (Sold separately)

#### For Motor

Product Name	Length L (m)
<b>LC2B06A</b>	0.6

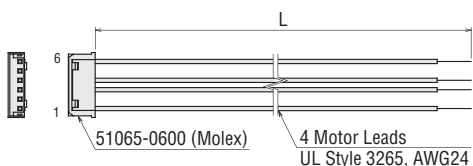

#### For Encoder

Product Name	Length L (m)
<b>LCE08A-006</b>	0.6

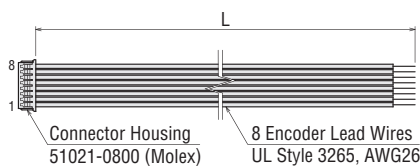

## Standard Type with Encoder Frame Size 28 mm (Unipolar 6 lead wires)

### Specifications

Product Name	Maximum Holding Torque N·m	Rotor Inertia J: kg·m <sup>2</sup>	Rated Current A/Phase	Voltage VDC	Winding Resistance Ω/Phase	Inductance mH/Phase	Basic Step Angle	Recommended Driver Product Name*
<b>PKP223U09A2-R2EL</b>	0.075	$9 \times 10^{-7}$	0.95	2.95	3.11	1.44	1.8°	<b>CMD2109P</b>
<b>PKP225U09A2-R2EL</b>	0.135	$18 \times 10^{-7}$		4.4	4.6	2.11		

● Refer to page A-430 for encoder specifications.

\*Refer to page A-445 for details on the recommended driver.

### Speed – Torque Characteristics (Reference values)

**PKP223U09A2-R2EL**

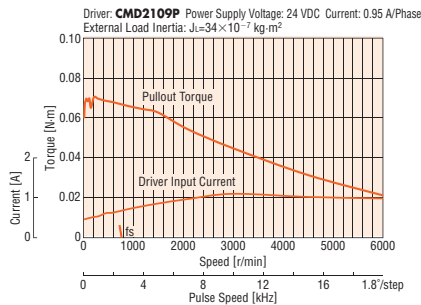

**PKP225U09A2-R2EL**

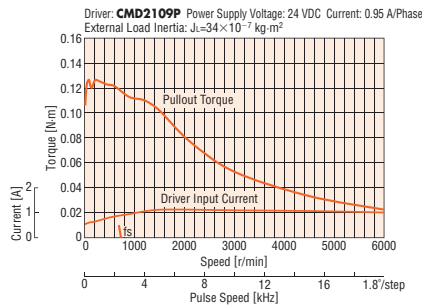

**Note**

- Data for the speed – torque characteristics is based on Oriental Motor's internal measurement conditions. If the conditions are changed, the characteristics may also change as a result.
- The data in the speed - torque characteristics represents the use of an external load inertia.
- Depending on the driving conditions, a considerable amount of heat may be generated by the motor. To protect the encoder, be sure to keep the motor case temperature at 85°C max.

### Dimensions (Unit = mm)

● Motor

Product Name	L	Mass kg
<b>PKP223U09A2-R2EL</b>	47.5	0.12
<b>PKP225U09A2-R2EL</b>	67	0.21

● Applicable Connector (Molex)

	Motor	Encoder
Connector Housing	51065-0600	51021-0800
Contact	50212-8100	50079-8100
Crimp Tool	57176-5000	57067-3000

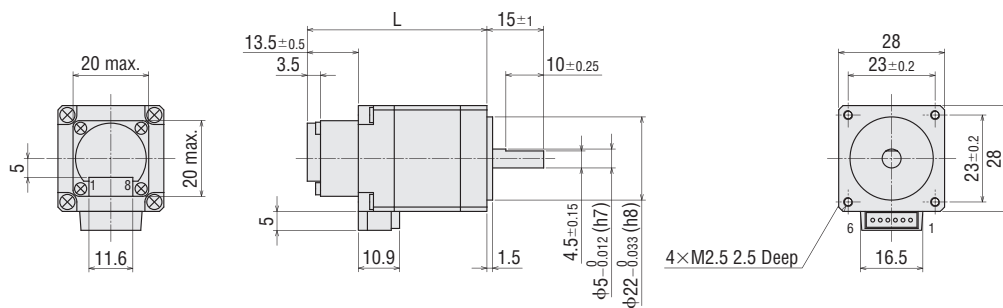

### Inner Wiring Diagram of Motor

Wiring Diagram No.: ⑥

● Refer to page A-431 for inner wiring diagram of motor.

### ● Connection Cable (Sold separately)

◇ For Motor

Product Name	Length L (m)
<b>LC2U06A</b>	0.6
<b>LC2U10A</b>	1

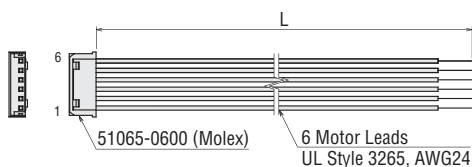

◇ For Encoder

Product Name	Length L (m)
<b>LCE08A-006</b>	0.6

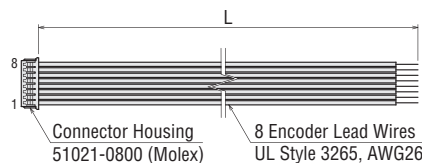

# Standard Type with Electromagnetic Brake

Frame Size 28 mm (Bipolar 4 lead wires)

## Specifications

Product Name	Maximum Holding Torque N·m	Rotor Inertia J: kg·m <sup>2</sup>	Rated Current A/Phase	Voltage VDC	Winding Resistance Ω/Phase	Inductance mH/Phase	Basic Step Angle
<b>PKP223D15M2</b>	0.095	14×10 <sup>-7</sup>	1.5	1.77	1.18	0.96	1.8°
<b>PKP225D15M2</b>	0.19	23×10 <sup>-7</sup>		3	2	1.6	

● Refer to page A-430 for electromagnetic brake specifications.

## Speed – Torque Characteristics (Reference values)

**PKP223D15M2**

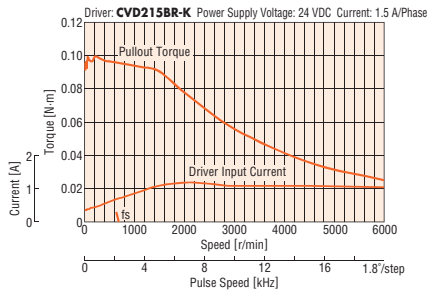

**PKP225D15M2**

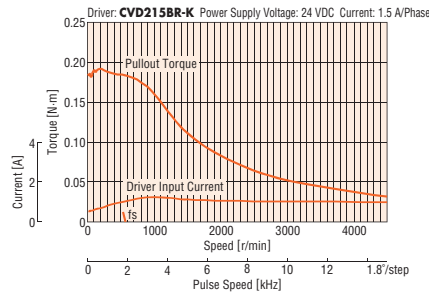

**Note**

- Data for the speed – torque characteristics is based on Oriental Motor's internal measurement conditions. If the conditions are changed, the characteristics may also change as a result.
- Depending on the driving conditions, a considerable amount of heat may be generated by the motor. Be sure to keep the motor case temperature at 100°C or less.

## Dimensions (Unit = mm)

● Motor

Product Name	L	Mass kg
<b>PKP223D15M2</b>	65.5	0.17
<b>PKP225D15M2</b>	85	0.26

● Applicable Connector

- Connector Housing: 51065-0600 (Molex)
- Contact: 50212-8100 (Molex)
- Crimp Tool: 57176-5000 (Molex)

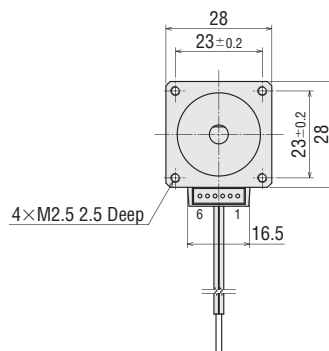
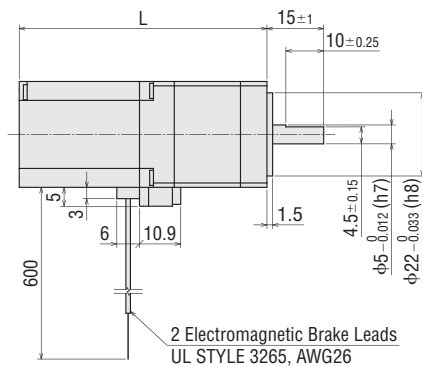

## Inner Wiring Diagram of Motor

Wiring Diagram No.: ②

- Refer to page A-431 for inner wiring diagram of motor.

● Connection Cable (Sold separately)

◇ For Motor

Product Name	Length L (m)
<b>LC2B06A</b>	0.6

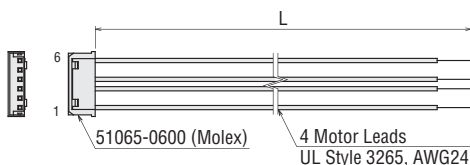

## Standard Type with Electromagnetic Brake Frame Size 28 mm (Unipolar 6 lead wires)

### Specifications

Product Name	Maximum Holding Torque N·m	Rotor Inertia J: kg·m <sup>2</sup>	Rated Current A/Phase	Voltage VDC	Winding Resistance Ω/Phase	Inductance mH/Phase	Basic Step Angle
<b>PKP223U09M2</b>	0.075	14 × 10 <sup>-7</sup>	0.95	2.95	3.11	1.44	1.8°
<b>PKP225U09M2</b>	0.135	23 × 10 <sup>-7</sup>		4.4	4.6	2.11	

● Refer to page A-430 for electromagnetic brake specifications.

### Speed – Torque Characteristics (Reference values)

**PKP223U09M2**

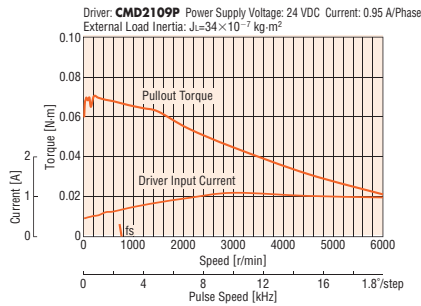

**PKP225U09M2**

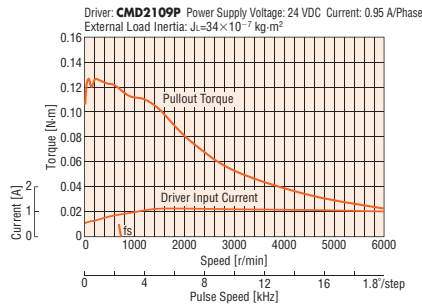

**Note**

- Data for the speed – torque characteristics is based on Oriental Motor's internal measurement conditions. If the conditions are changed, the characteristics may also change as a result.
- The data in the speed - torque characteristics represents the use of an external load inertia.
- Depending on the driving conditions, a considerable amount of heat may be generated by the motor. Be sure to keep the motor case temperature at 100°C or less.

### Dimensions (Unit = mm)

● Motor

Product Name	L	Mass kg
<b>PKP223U09M2</b>	65.5	0.17
<b>PKP225U09M2</b>	85	0.26

● Applicable Connector

Connector Housing: 51065-0600 (Molex)  
Contact: 50212-8100 (Molex)  
Crimp Tool: 57176-5000 (Molex)

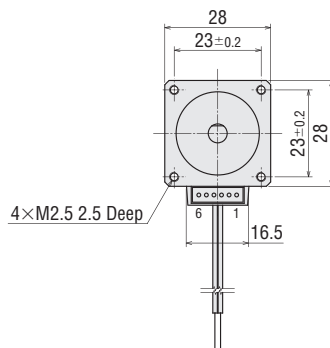
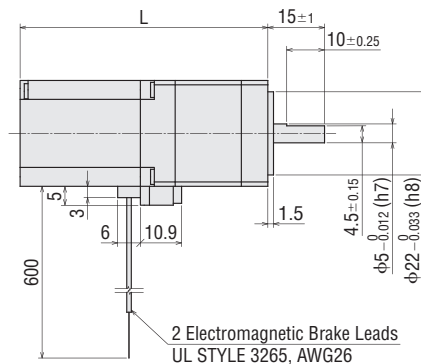

### Inner Wiring Diagram of Motor

Wiring Diagram No.: ⑥

● Refer to page A-431 for inner wiring diagram of motor.

### ● Connection Cable (Sold separately)

◇ For Motor

Product Name	Length L (m)
<b>LC2U06A</b>	0.6
<b>LC2U10A</b>	1

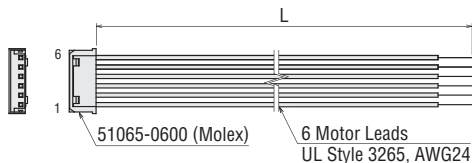

Overview,  
Product  
Series

AC Input  
Motor &  
Driver

0.36°/Geared  
**αSTEP**  
Absolute  
**AZ**

0.36°/Geared  
**αSTEP**  
**AR**

0.72°/Geared  
**RKII**

DC Input  
Motor &  
Driver

0.36°/Geared  
**αSTEP**  
Absolute  
**AZ**

0.36°/Geared  
**αSTEP**  
**AR**

1.8°/0.72°  
/0.36°  
**CVK**

0.72°/0.36°  
/Geared  
**CRK**

1.8°/Geared  
**RBK**

Motor Only  
/Driver Only

1.8°/0.9°  
**PKP/PK**

Geared  
**PKP/PK**

0.72°/0.36°  
**PKP/PK**

Driver

Accessories

# Standard Type Frame Size 35 mm (Bipolar 4 lead wires)

## Specifications

Product Name	Maximum Holding Torque N·m	Rotor Inertia J: kg·m <sup>2</sup>	Rated Current A/Phase	Voltage VDC	Winding Resistance Ω/Phase	Inductance mH/Phase	Basic Step Angle	Recommended Driver Product Name*
PKP233D15□	0.2	24×10 <sup>-7</sup>	1.5	2.43	1.62	1.5	1.8°	CVD215BR-K
PKP233D23□			2.3	1.56	0.68	0.67		CVD223BR-K
PKP235D15□	0.37	50×10 <sup>-7</sup>	1.5	3.6	2.4	2.6		CVD215BR-K
PKP235D23□			2.3	2.23	0.97	1.2		CVD223BR-K

● Either **A** (Single Shaft) or **B** (Double Shaft) indicating the configuration is specified where the box □ is located in the product name.  
\*Refer to page A-439 for details on the recommended driver.

## Speed – Torque Characteristics (Reference values)

PKP233D15A/PKP233D15B

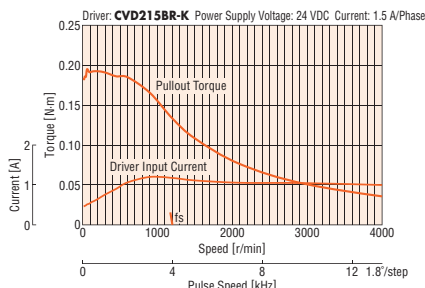

PKP235D15A/PKP235D15B

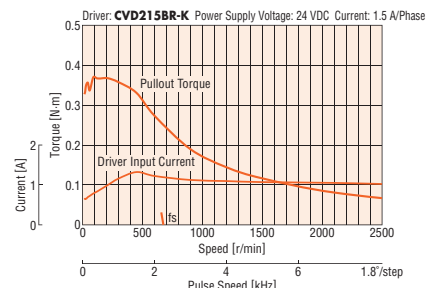

PKP233D23A/PKP233D23B

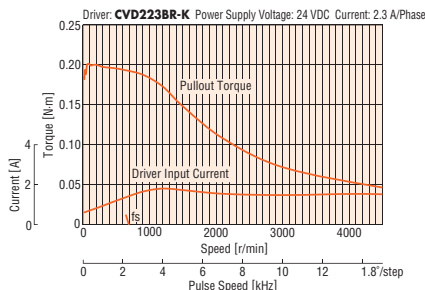

PKP235D23A/PKP235D23B

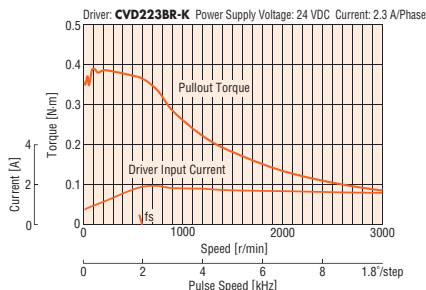

**Note**

- Data for the speed – torque characteristics is based on Oriental Motor's internal measurement conditions. If the conditions are changed, the characteristics may also change as a result.
- Depending on the driving conditions, a considerable amount of heat may be generated by the motor. Be sure to keep the motor case temperature at 100°C or less.

## Dimensions (Unit = mm)

### Motor

Product Name	L1	L2	Mass kg
PKP233D15A	37	—	0.18
PKP233D15B		52	
PKP233D23A		—	
PKP233D23B	52	52	0.285
PKP235D15A		—	
PKP235D15B		67	
PKP235D23A	52	—	0.285
PKP235D23B		67	

- Applicable Connector  
Connector Housing: 51103-0600 (Molex)  
Contact: 50351-8100 (Molex)  
Crimp Tool: 57295-5000 (Molex)

### Connection Cable (Sold separately)

#### ◇ For Motor

Product Name	Length L (m)
LC2B06B	0.6

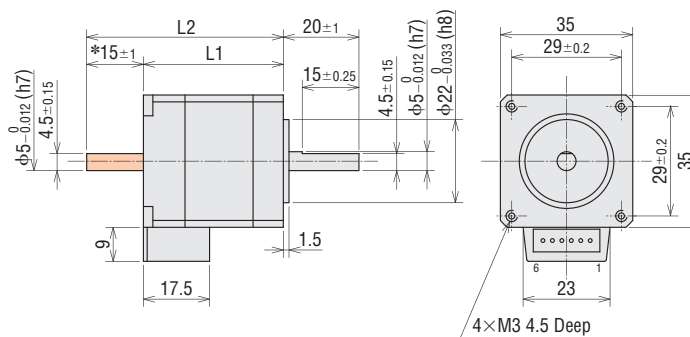
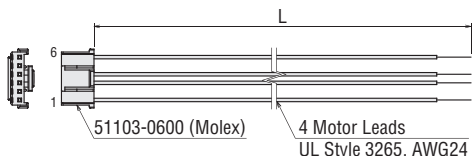

- \*The length of the shaft flat on the double shaft model is 15±0.25.
- These dimensions are for double shaft motors.  
For single shaft motors, ignore the shaded areas.

## Inner Wiring Diagram of Motor

Wiring Diagram No.: ②

- Refer to page A-431 for inner wiring diagram of motor.



## Standard Type Frame Size 35 mm (Unipolar 6 lead wires)

### Specifications

Product Name	Maximum Holding Torque N·m	Rotor Inertia J: kg·m <sup>2</sup>	Rated Current A/Phase	Voltage VDC	Winding Resistance Ω/Phase	Inductance mH/Phase	Basic Step Angle	Recommended Driver Product Name*
PKP233U12□	0.16	24×10 <sup>-7</sup>	1.2	3.24	2.7	1.4	1.8°	CMD2112P
PKP235U12□	0.3	50×10 <sup>-7</sup>		4.08	3.4	2		

● Either **A** (Single Shaft) or **B** (Double Shaft) indicating the configuration is specified where the box □ is located in the product name.

\*Refer to page A-445 for details on the recommended driver.

### Speed – Torque Characteristics (Reference values)

PKP233U12A/PKP233U12B

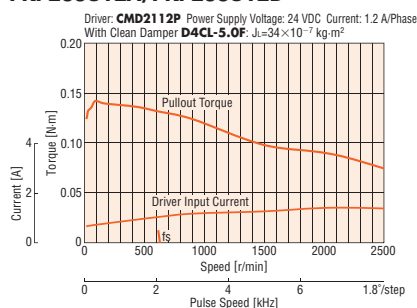

PKP235U12A/PKP235U12B

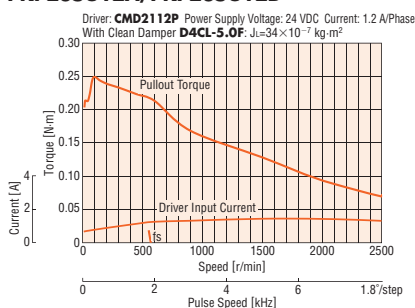

#### Note

- Data for the speed – torque characteristics is based on Oriental Motor's internal measurement conditions. If the conditions are changed, the characteristics may also change as a result.
- If there is a "clean damper" entry in the speed - torque characteristics, the data is for a double shaft motor when a clean damper is equipped.
- Depending on the driving conditions, a considerable amount of heat may be generated by the motor. Be sure to keep the motor case temperature at 100°C or less.

### Dimensions (Unit = mm)

#### Motor

Product Name	L1	L2	Mass kg
PKP233U12A	37	–	0.18
PKP233U12B		52	
PKP235U12A	52	–	0.285
PKP235U12B		67	

- Applicable Connector  
Connector Housing: 51103-0600 (Molex)  
Contact: 50351-8100 (Molex)  
Crimp Tool: 57295-5000 (Molex)

#### Connection Cable (Sold separately)

##### ◇ For Motor

Product Name	Length L (m)
LC2U06B	0.6
LC2U10B	1

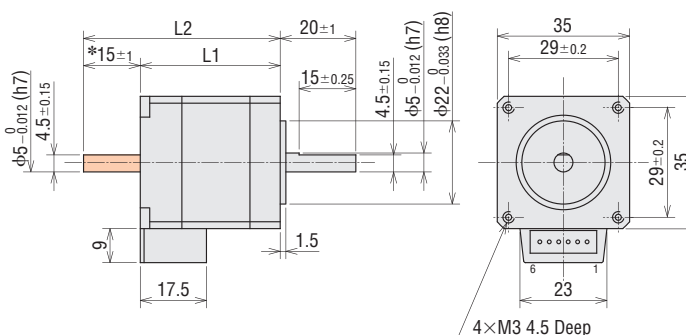
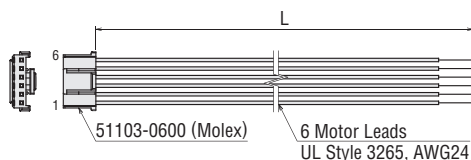

- \*The length of the shaft flat on the double shaft model is 15±0.25.
- These dimensions are for double shaft motors.  
For single shaft motors, ignore the shaded areas.

### Inner Wiring Diagram of Motor

Wiring Diagram No.: ⑥

- Refer to page A-431 for inner wiring diagram of motor.

Overview,  
Product  
Series

AC Input  
Motor &  
Driver

0.36°/Geared  
αSTEP  
Absolute  
AZ

0.36°/Geared  
αSTEP  
AR

0.72°/Geared  
RKII

DC Input  
Motor &  
Driver

0.36°/Geared  
αSTEP  
Absolute  
AZ

0.36°/Geared  
αSTEP  
AR

1.8°/0.72°  
/0.36°  
CVK

0.72°/0.36°  
/Geared  
CRK

1.8°/Geared  
RBK

Motor Only  
/Driver Only

1.8°/0.9°  
PKP/PK

Geared  
PKP/PK

0.72°/0.36°  
PKP/PK

Driver

Accessories

# Standard Type with Encoder Frame Size 35 mm (Bipolar 4 lead wires)

## Specifications

Product Name	Maximum Holding Torque N·m	Rotor Inertia J: kg·m <sup>2</sup>	Rated Current A/Phase	Voltage VDC	Winding Resistance Ω/Phase	Inductance mH/Phase	Basic Step Angle	Recommended Driver Product Name*
<b>PKP233D15A-R2EL</b>	0.2	$24 \times 10^{-7}$	1.5	2.43	1.62	1.5	1.8°	<b>CVD215BR-K</b>
<b>PKP235D15A-R2EL</b>	0.37	$50 \times 10^{-7}$		3.6	2.4	2.6		

● Refer to page A-430 for encoder specifications.

\*Refer to page A-439 for details on the recommended driver.

## Speed – Torque Characteristics (Reference values)

**PKP233D15A-R2EL**

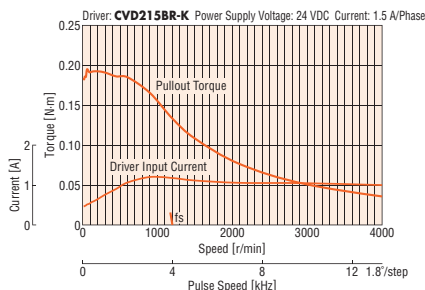

**PKP235D15A-R2EL**

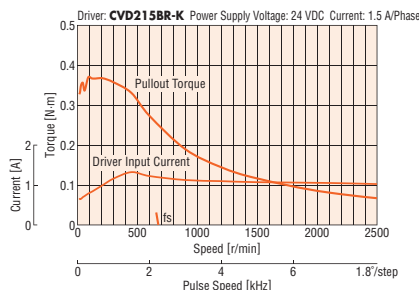

**Note**

- Data for the speed – torque characteristics is based on Oriental Motor's internal measurement conditions. If the conditions are changed, the characteristics may also change as a result.
- Depending on the driving conditions, a considerable amount of heat may be generated by the motor. To protect the encoder, be sure to keep the motor case temperature at 85°C max.

## Dimensions (Unit = mm)

### Motor

Product Name	L	Mass kg
<b>PKP233D15A-R2EL</b>	50.5	0.19
<b>PKP235D15A-R2EL</b>	65.5	0.295

● Applicable Connector (Molex)

	Motor	Encoder
Connector Housing	51103-0600	51021-0800
Contact	50351-8100	50079-8100
Crimp Tool	57295-5000	57067-3000

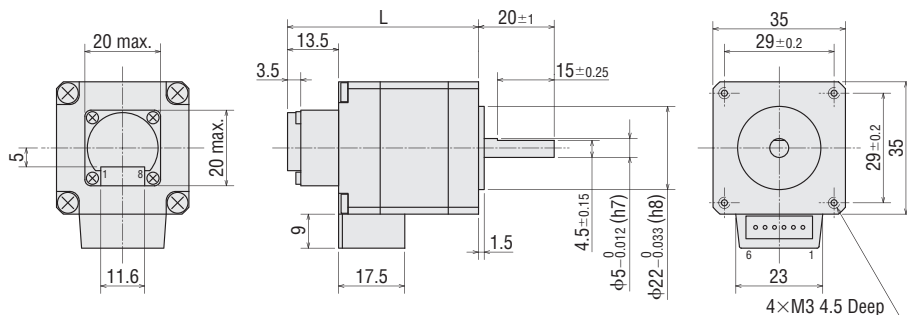

## Inner Wiring Diagram of Motor

Wiring Diagram No.: ②

● Refer to page A-431 for inner wiring diagram of motor.

### Connection Cable (Sold separately)

#### ◇ For Motor

Product Name	Length L (m)
<b>LC2B06B</b>	0.6

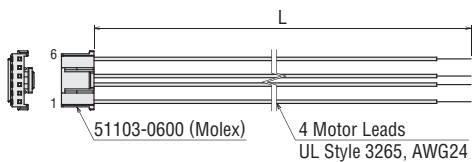

#### ◇ For Encoder

Product Name	Length L (m)
<b>LCE08A-006</b>	0.6

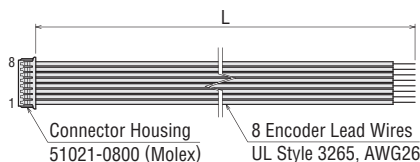

## Standard Type with Encoder Frame Size 35 mm (Unipolar 6 lead wires)

### Specifications

Product Name	Maximum Holding Torque N·m	Rotor Inertia J: kg·m <sup>2</sup>	Rated Current A/Phase	Voltage VDC	Winding Resistance Ω/Phase	Inductance mH/Phase	Basic Step Angle	Recommended Driver Product Name*
<b>PKP233U12A-R2EL</b>	0.16	$24 \times 10^{-7}$	1.2	3.24	2.7	1.4	1.8°	<b>CMD2112P</b>
<b>PKP235U12A-R2EL</b>	0.3	$50 \times 10^{-7}$		4.08	3.4	2		

● Refer to page A-430 for encoder specifications.

\*Refer to page A-445 for details on the recommended driver.

### Speed – Torque Characteristics (Reference values)

**PKP233U12A-R2EL**

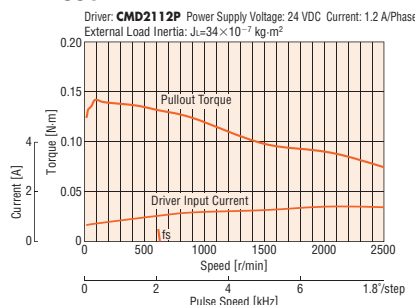

**PKP235U12A-R2EL**

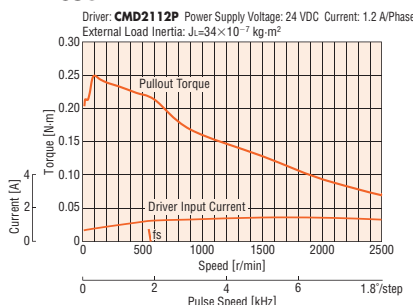

**Note**

- Data for the speed – torque characteristics is based on Oriental Motor's internal measurement conditions. If the conditions are changed, the characteristics may also change as a result.
- The data in the speed – torque characteristics represents the use of an external load inertia.
- Depending on the driving conditions, a considerable amount of heat may be generated by the motor. To protect the encoder, be sure to keep the motor case temperature at 85°C max.

### Dimensions (Unit = mm)

● Motor

Product Name	L	Mass kg
<b>PKP233U12A-R2EL</b>	50.5	0.19
<b>PKP235U12A-R2EL</b>	65.5	0.295

● Applicable Connector (Molex)

	Motor	Encoder
Connector Housing	51103-0600	51021-0800
Contact	50351-8100	50079-8100
Crimp Tool	57295-5000	57067-3000

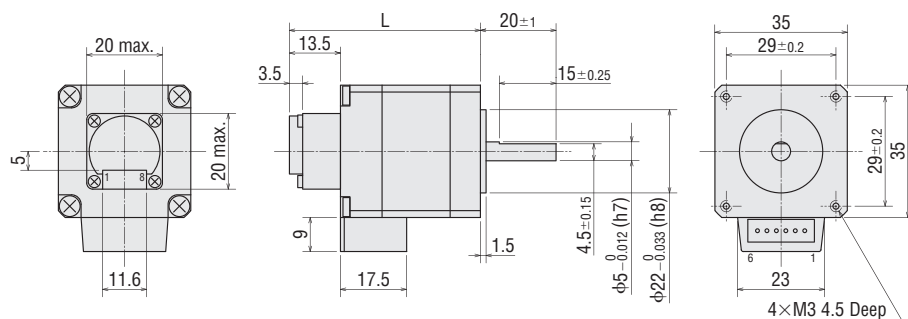

● Connection Cable (Sold separately)

◇ For Motor

Product Name	Length L (m)
<b>LC2U06B</b>	0.6
<b>LC2U10B</b>	1

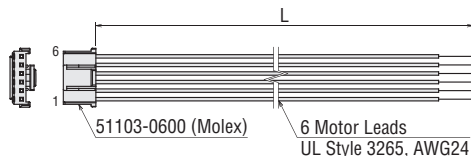

### Inner Wiring Diagram of Motor

Wiring Diagram No.: ⑥

● Refer to page A-431 for inner wiring diagram of motor.

◇ For Encoder

Product Name	Length L (m)
<b>LCE08A-006</b>	0.6

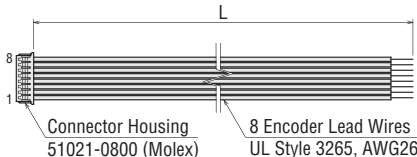

Overview,  
Product  
Series

AC Input  
Motor &  
Driver

0.36°/Geared  
**αSTEP**  
Absolute  
**AZ**

0.36°/Geared  
**αSTEP**  
**AR**

0.72°/Geared  
**RKII**

DC Input  
Motor &  
Driver

0.36°/Geared  
**αSTEP**  
Absolute  
**AZ**

0.36°/Geared  
**αSTEP**  
**AR**

1.8°/0.72°  
/0.36°  
**CVK**

0.72°/0.36°  
/Geared  
**CRK**

1.8°/Geared  
**RBK**

Motor Only  
/Driver Only

1.8°/0.9°  
**PKP/PK**

Geared  
**PKP/PK**

0.72°/0.36°  
**PKP/PK**

Driver

Accessories



## Standard Type with Electromagnetic Brake

Frame Size 35 mm (Unipolar 6 lead wires)

### Specifications

Product Name	Maximum Holding Torque N·m	Rotor Inertia J: kg·m <sup>2</sup>	Rated Current A/Phase	Voltage VDC	Winding Resistance Ω/Phase	Inductance mH/Phase	Basic Step Angle	Electromagnetic brake Static friction torque N·m
<b>PKP233U12M</b>	0.16	$36 \times 10^{-7}$	1.2	3.24	2.7	1.4	1.8°	0.3
<b>PKP235U12M</b>	0.3	$62 \times 10^{-7}$		4.08	3.4	2		

● Refer to page A-430 for electromagnetic brake specifications.

### Speed – Torque Characteristics (Reference values)

#### PKP233U12M

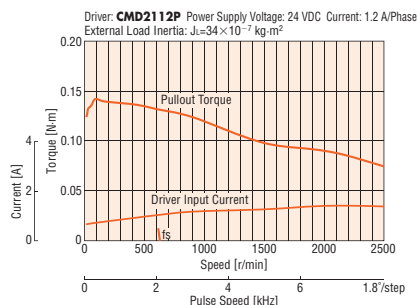

#### PKP235U12M

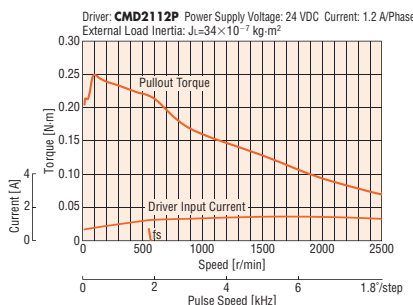

#### Note

- Data for the speed – torque characteristics is based on Oriental Motor's internal measurement conditions. If the conditions are changed, the characteristics may also change as a result.
- The data in the speed - torque characteristics represents the use of an external load inertia.
- Depending on the driving conditions, a considerable amount of heat may be generated by the motor. Be sure to keep the motor case temperature at 100°C or less.

### Dimensions (Unit = mm)

#### ● Motor

Product Name	L	Mass kg
<b>PKP233U12M</b>	71	0.285
<b>PKP235U12M</b>	86	0.39

- Applicable Connector (Molex)  
Connector Housing: 51103-0600  
Contact: 50351-8100  
Crimp Tool: 57295-5000

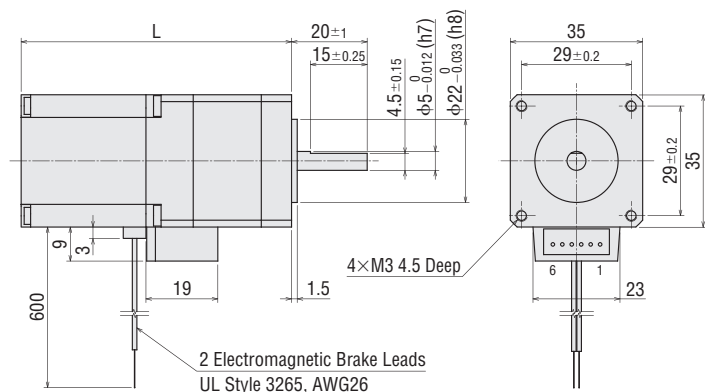

#### ● Connection Cable (Sold separately)

##### ◇ For Motor

Product Name	Length L (m)
<b>LC2U06B</b>	0.6
<b>LC2U10B</b>	1

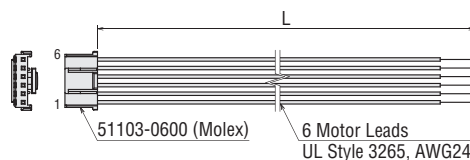

### Inner Wiring Diagram of Motor

Wiring Diagram No.: ⑥

- Refer to page A-431 for inner wiring diagram of motor.

Overview,  
Product  
Series

AC Input  
Motor &  
Driver

0.36°/Geared  
**αSTEP**  
Absolute  
**AZ**

0.36°/Geared  
**αSTEP**  
**AR**

0.72°/Geared  
**RKII**

DC Input  
Motor &  
Driver

0.36°/Geared  
**αSTEP**  
Absolute  
**AZ**

0.36°/Geared  
**αSTEP**  
**AR**

1.8°/0.72°  
/0.36°  
**CVK**

0.72°/0.36°  
/Geared  
**CRK**

1.8°/Geared  
**RBK**

Motor Only  
/Driver Only

1.8°/0.9°  
**PKP/PK**

Geared  
**PKP/PK**

0.72°/0.36°  
**PKP/PK**

Driver

Accessories

# Standard Type Frame Size 42 mm (Bipolar 4 lead wires)

## Specifications

Product Name	Maximum Holding Torque N·m	Rotor Inertia J: kg·m <sup>2</sup>	Rated Current A/Phase	Voltage VDC	Winding Resistance Ω/Phase	Inductance mH/Phase	Basic Step Angle	Recommended Driver Product Name*
<b>PKP243D15□2</b>	0.35	36×10 <sup>-7</sup>	1.5	2.7	1.8	3.3	1.8°	<b>CVD223FBR-K</b>
<b>PKP243D23□2</b>			2.3	1.8	0.78	1.4		
<b>PKP244D15□2</b>	0.48	54×10 <sup>-7</sup>	1.5	3.2	2.1	4.4		
<b>PKP244D23□2</b>			2.3	2.1	0.93	1.9		
<b>PKP245D15□2</b>	0.66	73×10 <sup>-7</sup>	1.5	3.3	2.2	5.3		
<b>PKP245D23□2</b>			2.3	2.3	1	2.2		
<b>PKP246D15□2</b>	0.99	110×10 <sup>-7</sup>	1.5	4.4	2.9	7.9		
<b>PKP246D23□2</b>			2.3	3.2	1.4	3.3		

● Either **A** (Single Shaft) or **B** (Double Shaft) indicating the configuration is specified where the box □ is located in the product name.  
\*Refer to page A-439 for details on the recommended driver.

## Speed – Torque Characteristics (Reference values)

**PKP243D15A2/PKP243D15B2**

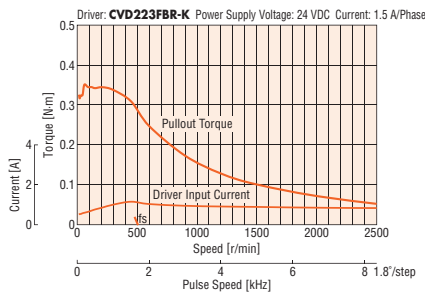

**PKP243D23A2/PKP243D23B2**

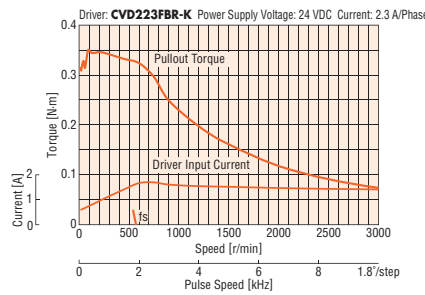

**PKP244D15A2/PKP244D15B2**

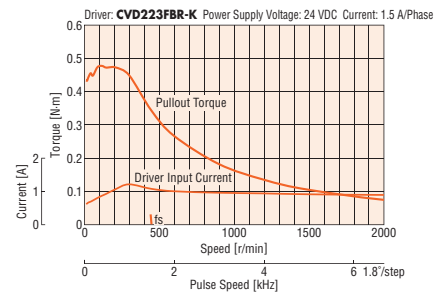

**PKP244D23A2/PKP244D23B2**

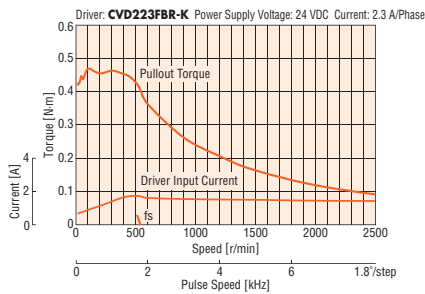

**PKP245D15A2/PKP245D15B2**

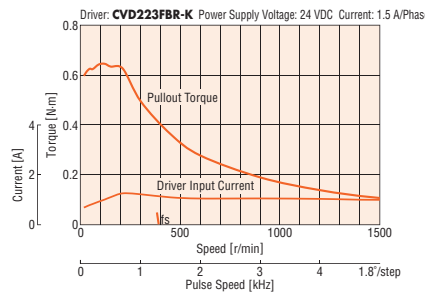

**PKP245D23A2/PKP245D23B2**

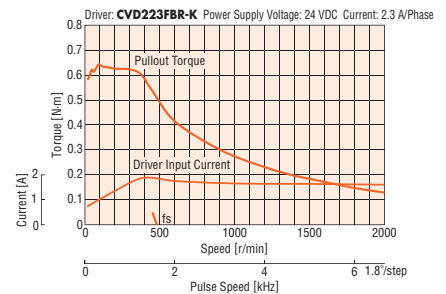

**PKP246D15A2/PKP246D15B2**

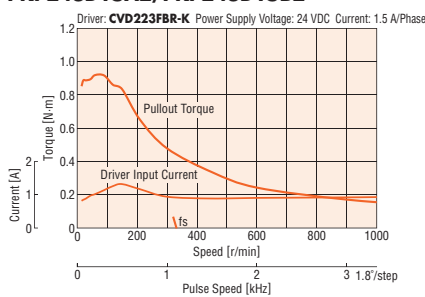

**PKP246D23A2/PKP246D23B2**

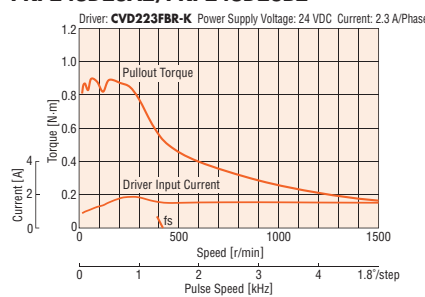

**Note**

- Data for the speed – torque characteristics is based on Oriental Motor's internal measurement conditions. If the conditions are changed, the characteristics may also change as a result.
- Depending on the driving conditions, a considerable amount of heat may be generated by the motor. Be sure to keep the motor case temperature at 100°C or less.

## Dimensions (Unit = mm)

### Motor

Product Name	L1	L2	Mass kg
PKP243D15A2	33	-	0.23
PKP243D15B2		48	
PKP243D23A2		-	
PKP243D23B2	39	48	0.3
PKP244D15A2		-	
PKP244D15B2		54	
PKP244D23A2	47	-	0.37
PKP244D23B2		54	
PKP245D15A2		-	
PKP245D15B2	47	62	0.37
PKP245D23A2		-	
PKP245D23B2		62	
PKP246D15A2	59	-	0.5
PKP246D15B2		74	
PKP246D23A2		-	
PKP246D23B2		74	

### Applicable Connector

Connector Housing: MDF97-5S-3.5C (HIROSE ELECTRIC CO., LTD.)  
 Contact: MDF97-22SC (HIROSE ELECTRIC CO., LTD.)  
 Crimp Tool: HT801/MDF97-22S (HIROSE ELECTRIC CO., LTD.)

### Connection Cable (Sold separately)

#### For Motor

Product Name	Length L (m)
LC2B06E	0.6

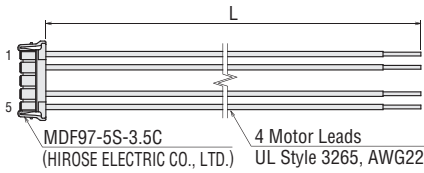

## Inner Wiring Diagram of Motor

Wiring Diagram No.: ①

Refer to page A-431 for inner wiring diagram of motor.

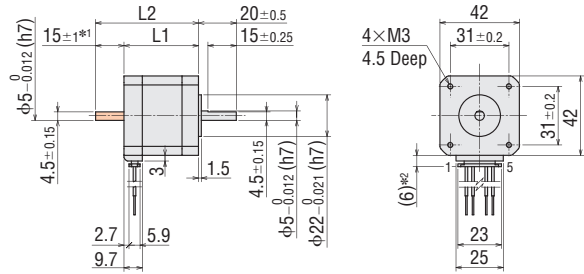

\*1 The length of the shaft flat on the double shaft model is  $15 \pm 0.25$ .

\*2 With connection cable

These dimensions are for double shaft motors.

For single shaft motors, ignore the shaded areas.

Overview,  
Product  
Series

AC Input  
Motor &  
Driver

0.36°/Geared  
**αSTEP**  
Absolute  
**AZ**

0.36°/Geared  
**αSTEP**  
**AR**

0.72°/Geared  
**RKII**

DC Input  
Motor &  
Driver

0.36°/Geared  
**αSTEP**  
Absolute  
**AZ**

0.36°/Geared  
**αSTEP**  
**AR**

1.8°/0.72°  
/0.36°  
**CVK**

0.72°/0.36°  
/Geared  
**CRK**

1.8°/Geared  
**RBK**

Motor Only  
/Driver Only

1.8°/0.9°  
**PKP/PK**

Geared  
**PKP/PK**

0.72°/0.36°  
**PKP/PK**

Driver

Accessories

# Standard Type Frame Size 42 mm (Unipolar 5 lead wires)

## Specifications

Product Name	Maximum Holding Torque N·m	Rotor Inertia J: kg·m <sup>2</sup>	Rated Current A/Phase	Voltage VDC	Winding Resistance Ω/Phase	Inductance mH/Phase	Basic Step Angle	Recommended Driver Product Name*
PKP243U09□2	0.26	36×10 <sup>-7</sup>	0.95	4.5	4.7	3.7	1.8°	<b>CMD2109P</b>
PKP244U12□2	0.39	54×10 <sup>-7</sup>	1.2	4.8	4	3.7		
PKP245U12□2	0.49	73×10 <sup>-7</sup>		3.8	3.2	3.7		
PKP246U12□2	0.75	110×10 <sup>-7</sup>		6.1	5.1	6		

● Either **A** (Single Shaft) or **B** (Double Shaft) indicating the configuration is specified where the box □ is located in the product name.  
\*Refer to page A-445 for details on the recommended driver.

## Speed – Torque Characteristics (Reference values)

### PKP243U09A2/PKP243U09B2

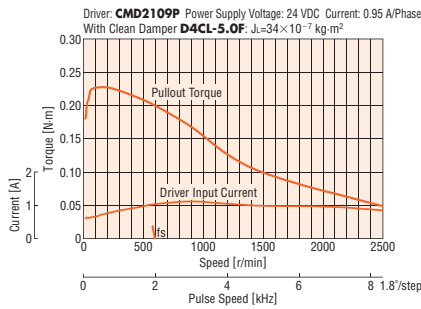

### PKP244U12A2/PKP244U12B2

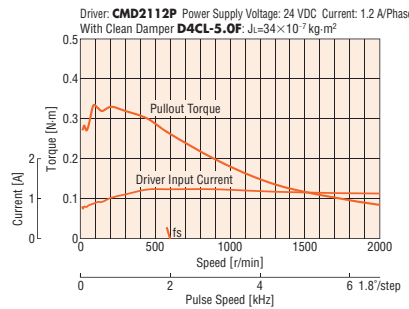

### PKP245U12A2/PKP245U12B2

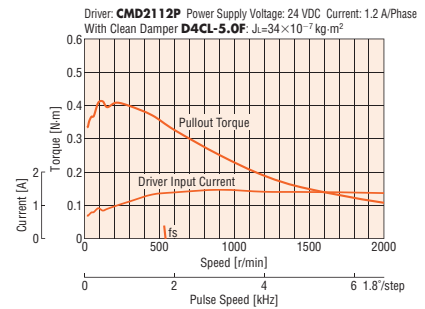

### PKP246U12A2/PKP246U12B2

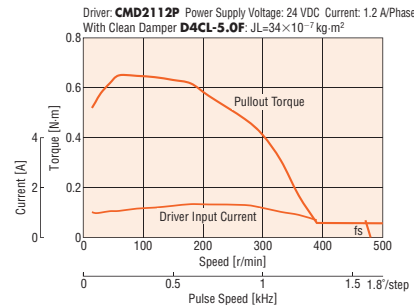

### Note

- Data for the speed – torque characteristics is based on Oriental Motor's internal measurement conditions. If the conditions are changed, the characteristics may also change as a result.
- If there is a "clean damper" entry in the speed – torque characteristics, the data is for a double shaft motor when a clean damper is equipped.
- Depending on the driving conditions, a considerable amount of heat may be generated by the motor. Be sure to keep the motor case temperature at 100°C or less.

## Dimensions (Unit = mm)

### Motor

Product Name	L1	L2	Mass kg
PKP243U09A2	33	—	0.23
PKP243U09B2		48	
PKP244U12A2	39	—	0.3
PKP244U12B2		54	
PKP245U12A2	47	—	0.37
PKP245U12B2		62	
PKP246U12A2	59	—	0.5
PKP246U12B2		74	

### Applicable Connector

Connector Housing: MDF97-5S-3.5C (HIROSE ELECTRIC CO., LTD.)  
Contact: MDF97-22SC (HIROSE ELECTRIC CO., LTD.)  
Crimp Tool: HT801/MDF97-22S (HIROSE ELECTRIC CO., LTD.)

### Connection Cable (Sold separately)

#### For Motor

Product Name	Length L (m)
<b>LC2U06E</b>	0.6

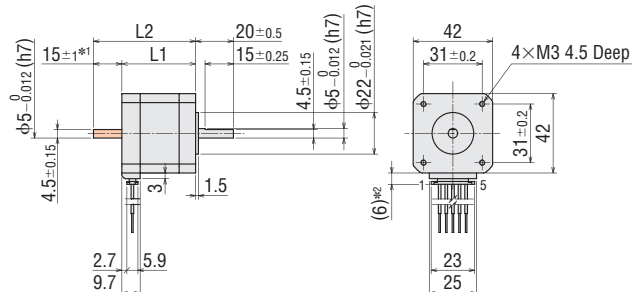
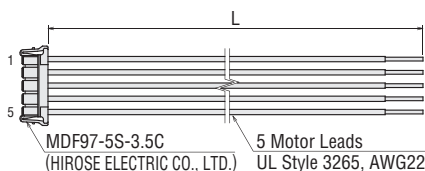

- \*1 The length of the shaft flat on the double shaft model is 15±0.25.
- \*2 With connection cable
- These dimensions are for double shaft motors.  
For single shaft motors, ignore the shaded areas.

## Inner Wiring Diagram of Motor

Wiring Diagram No.: ④

- Refer to page A-431 for inner wiring diagram of motor.



## Standard Type with Encoder Frame Size 42 mm (Bipolar 4 lead wires)

### Specifications

Product Name	Maximum Holding Torque N·m	Rotor Inertia J: kg·m <sup>2</sup>	Rated Current A/Phase	Voltage VDC	Winding Resistance Ω/Phase	Inductance mH/Phase	Basic Step Angle	Recommended Driver Product Name*
PKP243D15A2-R2EL	0.35	36×10 <sup>-7</sup>	1.5	2.7	1.8	3.3	1.8°	CVD223FBR-K
PKP243D15A2-R2FL			2.3	1.8	0.78	1.4		
PKP243D23A2-R2EL	0.48	54×10 <sup>-7</sup>	1.5	3.2	2.1	4.4		
PKP243D23A2-R2FL			2.3	2.1	0.93	1.9		
PKP244D15A2-R2EL	0.66	73×10 <sup>-7</sup>	1.5	3.3	2.2	5.3		
PKP244D15A2-R2FL			2.3	2.3	1	2.2		
PKP244D23A2-R2EL	0.99	110×10 <sup>-7</sup>	1.5	4.4	2.9	7.9		
PKP244D23A2-R2FL			2.3	3.2	1.4	3.3		

● Refer to page A-430 for encoder specifications.

\*Refer to page A-439 for details on the recommended driver.

### Speed – Torque Characteristics (Reference values)

PKP243D15A2-R2EL  
PKP243D15A2-R2FL

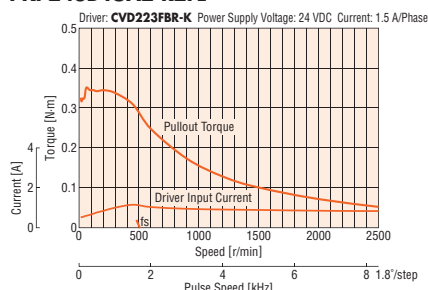

PKP243D23A2-R2EL  
PKP243D23A2-R2FL

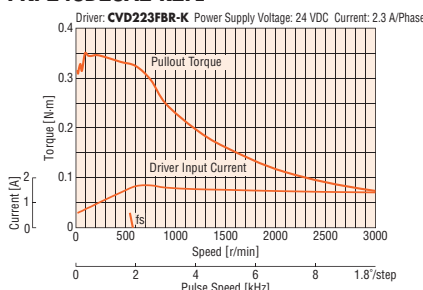

PKP244D15A2-R2EL  
PKP244D15A2-R2FL

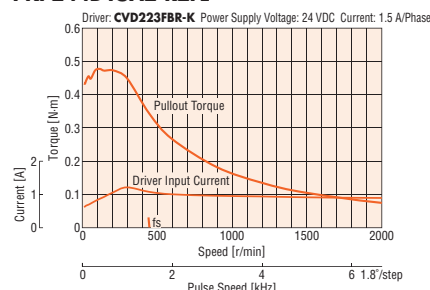

PKP244D23A2-R2EL  
PKP244D23A2-R2FL

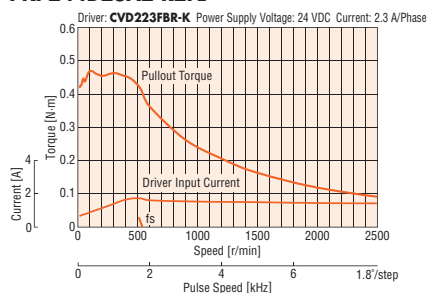

PKP245D15A2-R2EL  
PKP245D15A2-R2FL

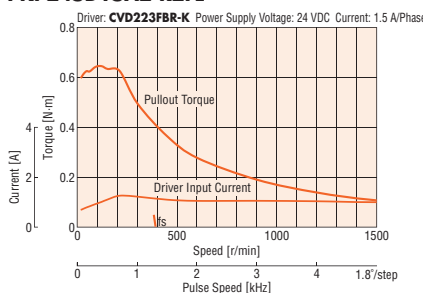

PKP245D23A2-R2EL  
PKP245D23A2-R2FL

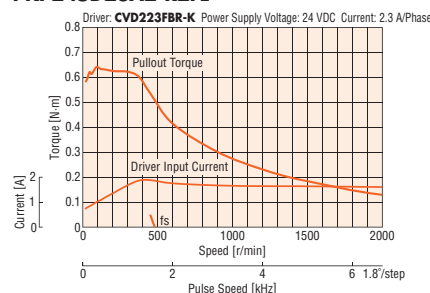

PKP246D15A2-R2EL  
PKP246D15A2-R2FL

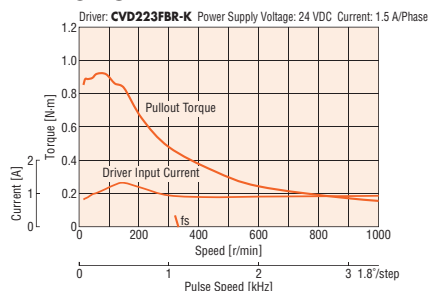

PKP246D23A2-R2EL  
PKP246D23A2-R2FL

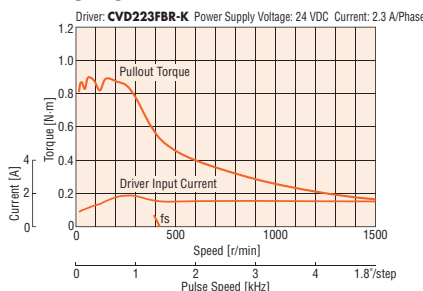

**Note**

- Data for the speed – torque characteristics is based on Oriental Motor's internal measurement conditions. If the conditions are changed, the characteristics may also change as a result.
- Depending on the driving conditions, a considerable amount of heat may be generated by the motor. To protect the encoder, be sure to keep the motor case temperature at 85°C max.

Overview, Product Series

AC Input Motor & Driver

0.36°/Geared  
αSTEP Absolute  
AZ

0.36°/Geared  
αSTEP AR

0.72°/Geared  
RKII

DC Input Motor & Driver

0.36°/Geared  
αSTEP Absolute  
AZ

0.36°/Geared  
αSTEP AR

1.8°/0.36°  
/0.36°  
CVK

0.72°/0.36°  
/Geared  
CRK

1.8°/Geared  
RBK

Motor Only / Driver Only

1.8°/0.9°  
PKP/PK

Geared  
PKP/PK

0.72°/0.36°  
PKP/PK

Driver

Accessories

**Dimensions (Unit = mm)**

● Motor

Product Name	L	Mass kg
PKP243D15A2-R2EL	46.5	0.24
PKP243D15A2-R2FL		
PKP243D23A2-R2EL		
PKP243D23A2-R2FL		
PKP244D15A2-R2EL	52.5	0.31
PKP244D15A2-R2FL		
PKP244D23A2-R2EL		
PKP244D23A2-R2FL		
PKP245D15A2-R2EL	60.5	0.38
PKP245D15A2-R2FL		
PKP245D23A2-R2EL		
PKP245D23A2-R2FL		
PKP246D15A2-R2EL	72.5	0.51
PKP246D15A2-R2FL		
PKP246D23A2-R2EL		
PKP246D23A2-R2FL		

● Applicable Connector

	Motor (HIROSE ELECTRIC CO., LTD.)	Encoder (Molex)
Connector Housing	MDF97-5S-3.5C	51021-0800
Contact	MDF97-22SC	50079-8100
Crimp Tool	HT801/MDF97-22S	57067-3000

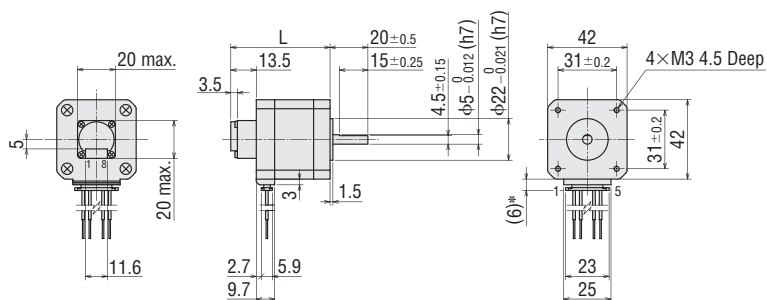

\*With connection cable

● Connection Cable (Sold separately)

◇ For Motor

Product Name	Length L (m)
LC2B06E	0.6

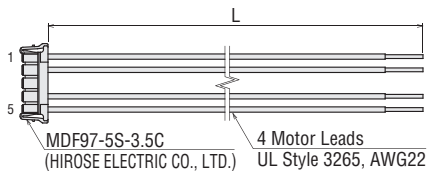

◇ For Encoder

Product Name	Length L (m)
LCE08A-006	0.6

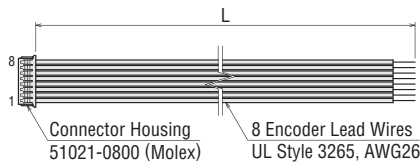

**Inner Wiring Diagram of Motor**

Wiring Diagram No.: ①

● Refer to page A-431 for inner wiring diagram of motor.

## Standard Type with Encoder Frame Size 42 mm (Unipolar 5 lead wires)

### Specifications

Product Name	Maximum Holding Torque N·m	Rotor Inertia J: kg·m <sup>2</sup>	Rated Current A/Phase	Voltage VDC	Winding Resistance Ω/Phase	Inductance mH/Phase	Basic Step Angle	Recommended Driver Product Name*
<b>PKP243U09A2-R2EL</b>	0.26	36×10 <sup>-7</sup>	0.95	4.5	4.7	3.7	1.8°	<b>CMD2109P</b>
<b>PKP243U09A2-R2FL</b>								
<b>PKP244U12A2-R2EL</b>	0.39	54×10 <sup>-7</sup>	1.2	4.8	4	3.7		<b>CMD2112P</b>
<b>PKP244U12A2-R2FL</b>								
<b>PKP245U12A2-R2EL</b>	0.49	73×10 <sup>-7</sup>	1.2	3.8	3.2	3.7		<b>CMD2112P</b>
<b>PKP245U12A2-R2FL</b>								
<b>PKP246U12A2-R2EL</b>	0.75	110×10 <sup>-7</sup>	1.2	6.1	5.1	6	<b>CMD2112P</b>	
<b>PKP246U12A2-R2FL</b>								

● Refer to page A-430 for encoder specifications.

\*Refer to page A-445 for details on the recommended driver.

### Speed – Torque Characteristics (Reference values)

**PKP243U09A2-R2EL/PKP243U09A2-R2FL**

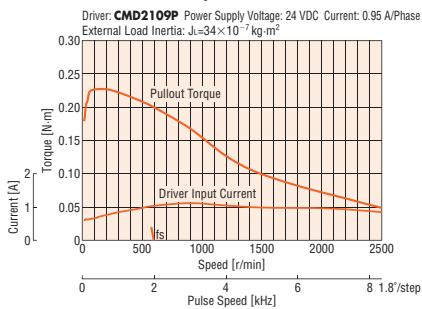

**PKP244U12A2-R2EL/PKP244U12A2-R2FL**

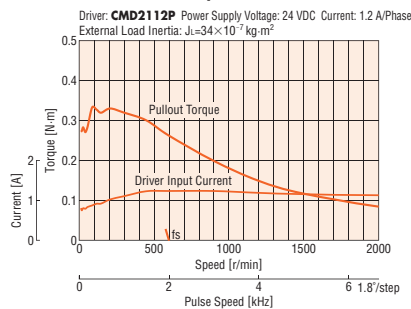

**PKP245U12A2-R2EL/PKP245U12A2-R2FL**

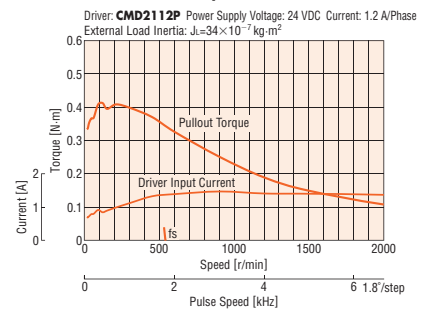

**PKP246U12A2-R2EL/PKP246U12A2-R2FL**

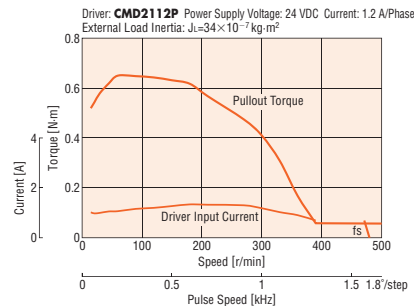

#### Note

- Data for the speed – torque characteristics is based on Oriental Motor's internal measurement conditions. If the conditions are changed, the characteristics may also change as a result.
- The data in the speed – torque characteristics represents the use of an external load inertia.
- Depending on the driving conditions, a considerable amount of heat may be generated by the motor. To protect the encoder, be sure to keep the motor case temperature at 85°C max.

### Dimensions (Unit = mm)

#### ● Motor

Product Name	L	Mass kg
<b>PKP243U09A2-R2EL, PKP243U09A2-R2FL</b>	46.5	0.24
<b>PKP244U12A2-R2EL, PKP244U12A2-R2FL</b>	52.5	0.31
<b>PKP245U12A2-R2EL, PKP245U12A2-R2FL</b>	60.5	0.38
<b>PKP246U12A2-R2EL, PKP246U12A2-R2FL</b>	72.5	0.51

● Applicable Connector

	Motor (HIROSE ELECTRIC CO., LTD.)	Encoder (Molex)
Connector Housing	MDF97-5S-3.5C	51021-0800
Contact	MDF97-22SC	50079-8100
Crimp Tool	HT801/MDF97-22S	57067-3000

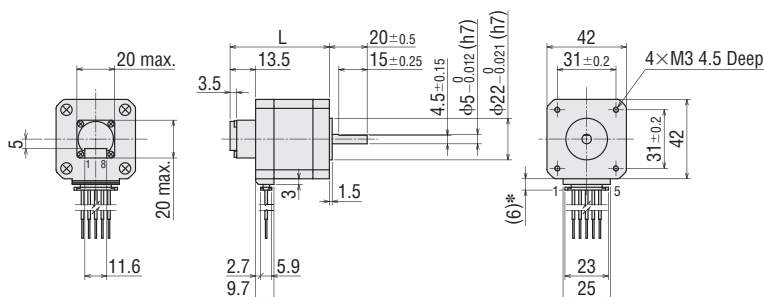

\*With connection cable

#### ● Connection Cable (Sold separately)

##### ◇ For Motor

Product Name	Length L (m)
<b>LC2U06E</b>	0.6

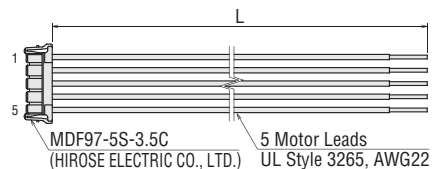

##### ◇ For Encoder

Product Name	Length L (m)
<b>LCE08A-006</b>	0.6

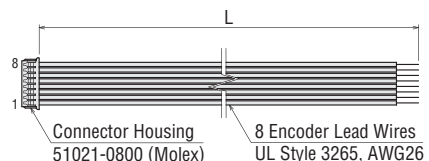

### Inner Wiring Diagram of Motor

Wiring Diagram No.: ④

● Refer to page A-431 for inner wiring diagram of motor.

Overview,  
Product  
Series

AC Input  
Motor &  
Driver

0.36°/Geared  
αSTEP  
Absolute  
AZ

0.36°/Geared  
αSTEP  
AR

0.72°/Geared  
RKII

DC Input  
Motor &  
Driver

0.36°/Geared  
αSTEP  
Absolute  
AZ

0.36°/Geared  
αSTEP  
AR

1.8°/0.72°  
/0.36°  
CVK

0.72°/0.36°  
/GEARED  
CRK

1.8°/Geared  
RBK

Motor Only  
/Driver Only

1.8°/0.9°  
PKP/PK

Geared  
PKP/PK

0.72°/0.36°  
PKP/PK

Driver

Accessories

# Standard Type with Electromagnetic Brake

Frame Size 42 mm (Bipolar 4 lead wires)

## Specifications

Product Name	Maximum Holding Torque N·m	Rotor Inertia J: kg·m <sup>2</sup>	Rated Current A/Phase	Voltage VDC	Winding Resistance Ω/Phase	Inductance mH/Phase	Basic Step Angle	Electromagnetic Brake Static Friction Torque N·m
<b>PKP243D15M</b>	0.35	48 × 10 <sup>-7</sup>	1.5	2.85	1.9	5	1.8°	0.3
<b>PKP244D15M</b>	0.48	69 × 10 <sup>-7</sup>		3.9	2.6	4.9		
<b>PKP245D15M</b>	0.58	95 × 10 <sup>-7</sup>		3.6	2.4	6.6		
<b>PKP246D15M</b>	0.93	126 × 10 <sup>-7</sup>		5.8	3.87	8		

● Refer to page A-430 for electromagnetic brake specifications.

## Speed – Torque Characteristics (Reference values)

**PKP243D15M**

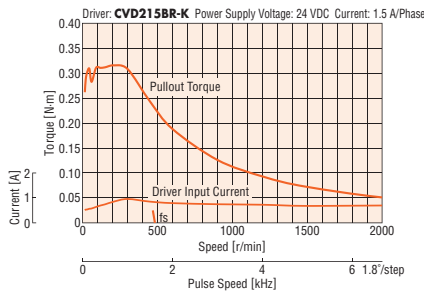

**PKP244D15M**

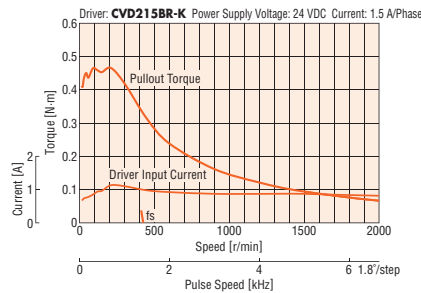

**PKP245D15M**

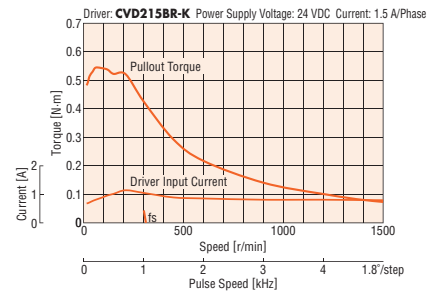

**PKP246D15M**

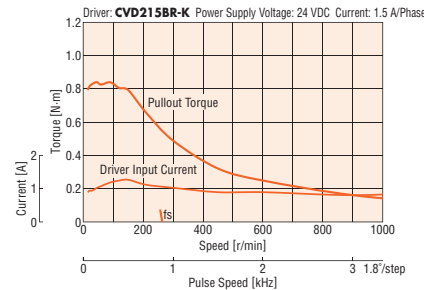

**Note**

- Data for the speed – torque characteristics is based on Oriental Motor's internal measurement conditions. If the conditions are changed, the characteristics may also change as a result.
- Depending on the driving conditions, a considerable amount of heat may be generated by the motor. Be sure to keep the motor case temperature at 100°C or less.

## Dimensions (Unit = mm)

### ● Motor

Product Name	L	Mass kg
<b>PKP243D15M</b>	67	0.36
<b>PKP244D15M</b>	73	0.41
<b>PKP245D15M</b>	81	0.5
<b>PKP246D15M</b>	93	0.61

- Applicable Connector (Molex)  
Connector Housing: 51103-0600  
Contact: 50351-8100  
Crimp Tool: 57295-5000

### ● Connection Cable (Sold separately)

#### ◇ For Motor

Product Name	Length L (m)
<b>LC2B06B</b>	0.6

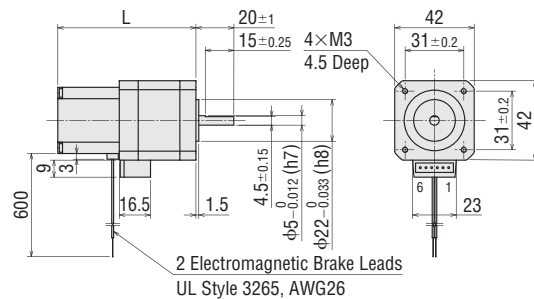
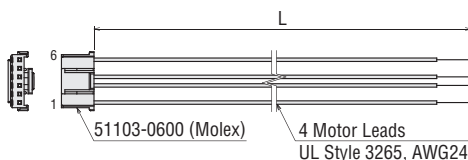

## Inner Wiring Diagram of Motor

Wiring Diagram No.: ②

- Refer to page A-431 for inner wiring diagram of motor.

## Standard Type with Electromagnetic Brake

Frame Size 42 mm (Unipolar 6 lead wires)

### Specifications

Product Name	Maximum Holding Torque N·m	Rotor Inertia J: kg·m <sup>2</sup>	Rated Current A/Phase	Voltage VDC	Winding Resistance Ω/Phase	Inductance mH/Phase	Basic Step Angle	Electromagnetic Brake Static Friction Torque N·m
<b>PKP243U09M</b>	0.25	$48 \times 10^{-7}$	0.95	4.47	4.7	5	1.8°	0.3
<b>PKP244U12M</b>	0.39	$69 \times 10^{-7}$	1.2	4.8	4	3.9		
<b>PKP245U12M</b>	0.45	$95 \times 10^{-7}$		4.56	3.8	5		
<b>PKP246U12M</b>	0.75	$126 \times 10^{-7}$		7.2	6	6.5		

● Refer to page A-430 for electromagnetic brake specifications.

### Speed – Torque Characteristics (Reference values)

**PKP243U09M**

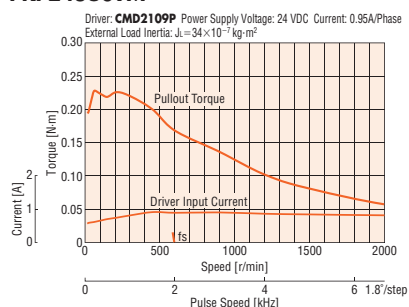

**PKP244U12M**

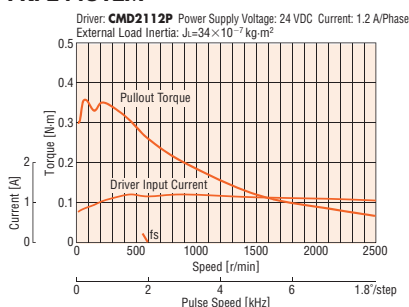

**PKP245U12M**

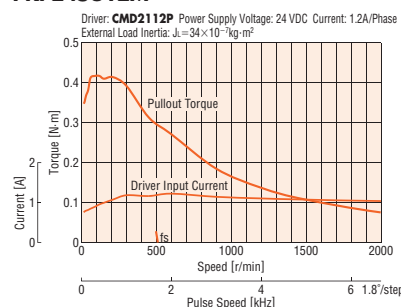

**PKP246U12M**

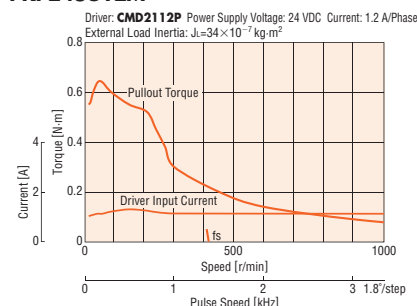

#### Note

- Data for the speed – torque characteristics is based on Oriental Motor's internal measurement conditions. If the conditions are changed, the characteristics may also change as a result.
- The data in the speed – torque characteristics represents the use of an external load inertia.
- Depending on the driving conditions, a considerable amount of heat may be generated by the motor. Be sure to keep the motor case temperature at 100°C or less.

### Dimensions (Unit = mm)

#### ● Motor

Product Name	L	Mass kg
<b>PKP243U09M</b>	67	0.36
<b>PKP244U12M</b>	73	0.41
<b>PKP245U12M</b>	81	0.5
<b>PKP246U12M</b>	93	0.61

- Applicable Connector (Molex)  
Connector Housing: 51103-0600  
Contact: 50351-8100  
Crimp Tool: 57295-5000

#### ● Connection Cable (Sold separately)

##### ◇ For Motor

Product Name	Length L (m)
<b>LC2U06B</b>	0.6
<b>LC2U10B</b>	1

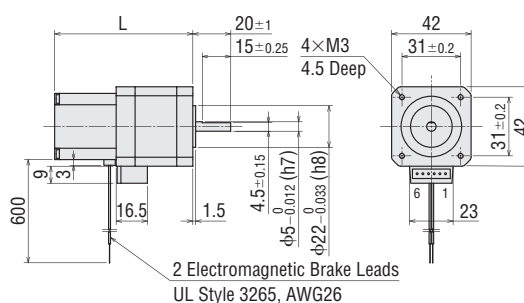
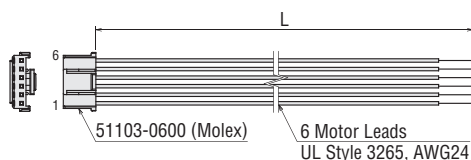

### Inner Wiring Diagram of Motor

Wiring Diagram No.: ⑥

● Refer to page A-431 for inner wiring diagram of motor.

Overview,  
Product  
Series

AC Input  
Motor &  
Driver

0.36°/Geared  
αSTEP  
Absolute  
AZ

0.36°/Geared  
αSTEP  
AR

0.72°/Geared  
RKII

DC Input  
Motor &  
Driver

0.36°/Geared  
αSTEP  
Absolute  
AZ

0.36°/Geared  
αSTEP  
AR

1.8°/0.72°  
/0.36°  
CVK

0.72°/0.36°  
/Geared  
CRK

1.8°/Geared  
RBK

Motor Only  
/Driver Only

1.8°/0.9°  
PKP/PK

Geared  
PKP/PK

0.72°/0.36°  
PKP/PK

Driver

Accessories

# Standard Type Frame Size 50 mm (Unipolar 6 lead wires)

## Specifications

Product Name	Maximum Holding Torque N·m	Rotor Inertia J: kg·m <sup>2</sup>	Rated Current A/Phase	Voltage VDC	Winding Resistance Ω/Phase	Inductance mH/Phase	Basic Step Angle	Recommended Driver Product Name*
PK256-02□	0.6	230×10 <sup>-7</sup>	2	3	1.5	1.4	1.8°	CMD2120P
PK258-02□	1.2	420×10 <sup>-7</sup>		4.8	2.4	2.87		

● Either **A** (Single Shaft) or **B** (Double Shaft) indicating the configuration is specified where the box □ is located in the product name.

\*Refer to page A-445 for details on the recommended driver.

## Speed – Torque Characteristics (Reference values)

PK256-02A/PK256-02B

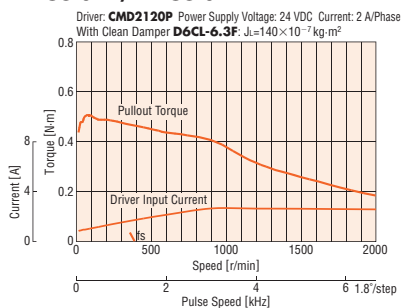

PK258-02A/PK258-02B

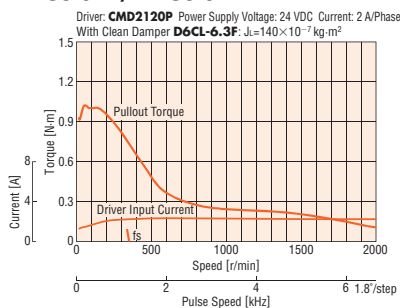

**Note**

- Data for the speed – torque characteristics is based on Oriental Motor's internal measurement conditions. If the conditions are changed, the characteristics may also change as a result.
- If there is a "clean damper" entry in the speed – torque characteristics, the data is for a double shaft motor when a clean damper is equipped.
- Depending on the driving conditions, a considerable amount of heat may be generated by the motor. Be sure to keep the motor case temperature at 100°C or less.

## Dimensions (Unit = mm)

● Motor

Product Name	L1	L2	Mass kg
PK256-02A	51.5	—	0.53
PK256-02B		67.5	
PK258-02A	81	—	0.89
PK258-02B		97	

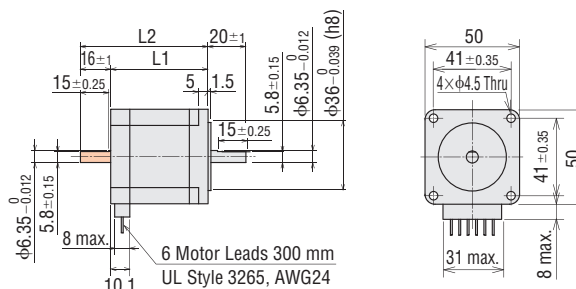

- These dimensions are for double shaft motors.  
For single shaft motors, ignore the shaded areas.

## Inner Wiring Diagram of Motor

Wiring Diagram No.: ⑦

- Refer to page A-431 for inner wiring diagram of motor.

## Standard Type Frame Size 56.4 mm (Bipolar 4 lead wires)

### Specifications

Product Name	Maximum Holding Torque N·m	Rotor Inertia J: kg·m <sup>2</sup>	Rated Current A/Phase	Voltage VDC	Winding Resistance Ω/Phase	Inductance mH/Phase	Basic Step Angle	Recommended Driver Product Name*			
PKP264D14□2	0.74	140×10 <sup>-7</sup>	1.4	2.9	2.1	6	1.8°	CVD228BR-K			
PKP264D28□2			2.8	1.6	0.57	1.5			CVD242BR-K		
PKP264D42□2			4.2	1	0.24	0.65					
PKP266D14□2	1.4	270×10 <sup>-7</sup>	1.4	4.6	3.3	12		1.8°	CVD228BR-K		
PKP266D28□2			2.8	2.4	0.86	2.9				CVD242BR-K	
PKP266D42□2			4.2	1.6	0.38	1.3					
PKP268D14□2	2.5	500×10 <sup>-7</sup>	1.4	6.6	4.7	18			1.8°	CVD228BR-K	
PKP268D28□2			2.8	3.4	1.2	4.6					CVD242BR-K
PKP268D42□2			4.2	2.2	0.53	2					

● Either **A** (Single Shaft) or **B** (Double Shaft) indicating the configuration is specified where the box □ is located in the product name.  
\*Refer to page A-439 for details on the recommended driver.

### Speed – Torque Characteristics (Reference values)

PKP264D14A2/PKP264D14B2

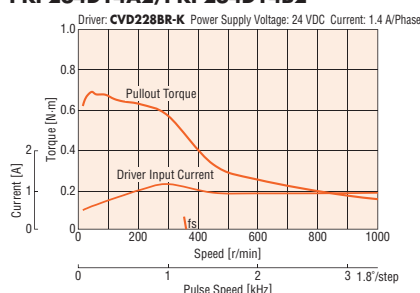

PKP264D28A2/PKP264D28B2

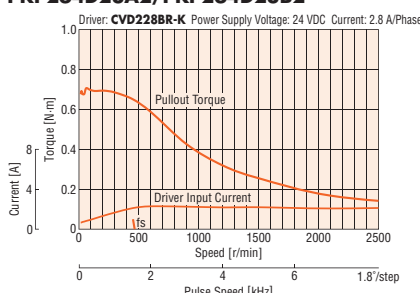

PKP264D42A2/PKP264D42B2

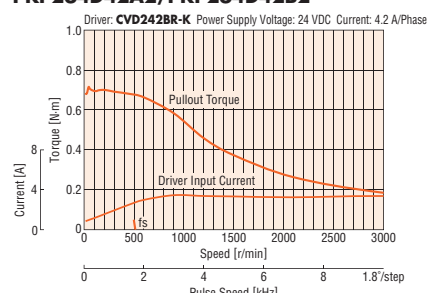

PKP266D14A2/PKP266D14B2

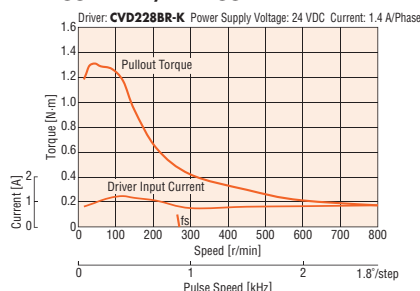

PKP266D28A2/PKP266D28B2

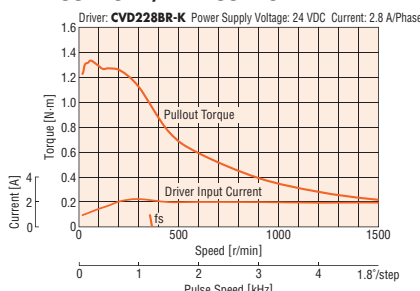

PKP266D42A2/PKP266D42B2

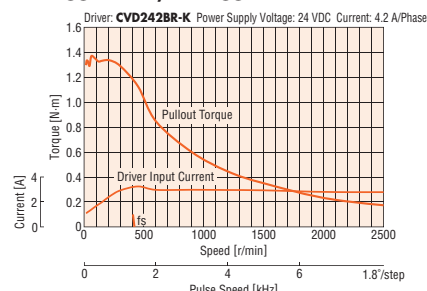

PKP268D14A2/PKP268D14B2

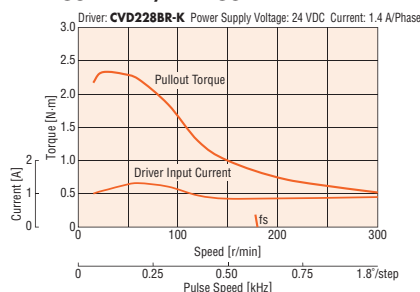

PKP268D28A2/PKP268D28B2

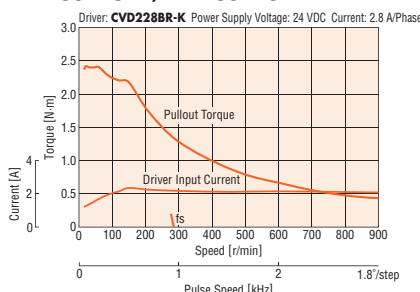

PKP268D42A2/PKP268D42B2

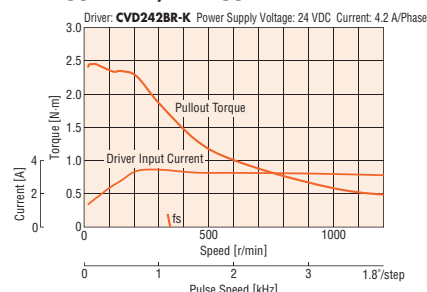

#### Note

- Data for the speed – torque characteristics is based on Oriental Motor's internal measurement conditions. If the conditions are changed, the characteristics may also change as a result.
- Depending on the driving conditions, a considerable amount of heat may be generated by the motor. Be sure to keep the motor case temperature at 100°C or less.

Overview, Product Series

AC Input Motor & Driver

0.36°/Geared Absolute AZ

0.36°/Geared Absolute AR

0.72°/Geared RK II

DC Input Motor & Driver

0.36°/Geared Absolute AZ

0.36°/Geared Absolute AR

1.8°/0.72°/0.36° CVK

0.72°/0.36°/Geared CRK

1.8°/Geared RBK

Motor Only /Driver Only

1.8°/0.9° PKP/PK

Geared PKP/PK

0.72°/0.36° PKP/PK

Driver

Accessories

**Dimensions (Unit = mm)**

● Motor

Product Name	L1	L2	Mass kg
PKP264D14A2	39	-	0.45
PKP264D14B2		62	
PKP264D28A2		-	
PKP264D28B2		62	
PKP264D42A2		-	
PKP264D42B2	62	-	
PKP266D14A2	54	-	0.7
PKP266D14B2		77	
PKP266D28A2		-	
PKP266D28B2		77	
PKP266D42A2		-	
PKP266D42B2	77	-	
PKP268D14A2	76	-	1.1
PKP268D14B2		99	
PKP268D28A2		-	
PKP268D28B2		99	
PKP268D42A2		-	
PKP268D42B2	99	-	

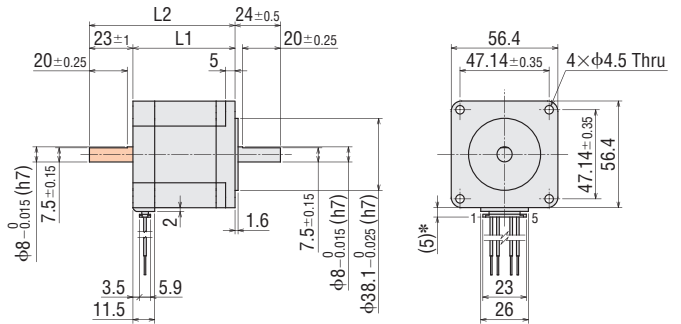

\*With connection cable  
● These dimensions are for double shaft motors.  
For single shaft motors, ignore the shaded areas.

● Applicable Connector

Connector Housing: MDF97-5S-3.5C (HIROSE ELECTRIC CO., LTD.)  
Contact: MDF97-22SC (HIROSE ELECTRIC CO., LTD.)  
Crimp Tool: HT801/MDF97-22S (HIROSE ELECTRIC CO., LTD.)

● Connection Cable (Sold separately)

◇ For Motor

Product Name	Length L (m)
LC2B06E	0.6

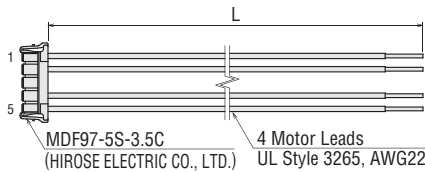

**Inner Wiring Diagram of Motor**

Wiring Diagram No.: ①

● Refer to page A-431 for inner wiring diagram of motor.



## Standard Type Frame Size 56.4 mm (Unipolar 5 lead wires)

### Specifications

Product Name	Maximum Holding Torque N·m	Rotor Inertia J: kg·m <sup>2</sup>	Rated Current A/Phase	Voltage VDC	Winding Resistance Ω/Phase	Inductance mH/Phase	Basic Step Angle	Recommended Driver Product Name*
PKP264U10□2	0.58	140×10 <sup>-7</sup>	1	4.4	4.4	6	1.8°	CMD2120P
PKP264U20□2			2	2.2	1.1	1.5		
PKP266U10□2	1.1	270×10 <sup>-7</sup>	1	6.9	6.9	11.6		
PKP266U20□2			2	3.4	1.7	2.9		
PKP268U10□2	2	500×10 <sup>-7</sup>	1	9.9	9.9	18.4		
PKP268U20□2			2	4.8	2.4	4.6		

● Either **A** (Single Shaft) or **B** (Double Shaft) indicating the configuration is specified where the box □ is located in the product name.  
\*Refer to page A-445 for details on the recommended driver.

### Speed – Torque Characteristics (Reference values)

PKP264U10A2/PKP264U10B2

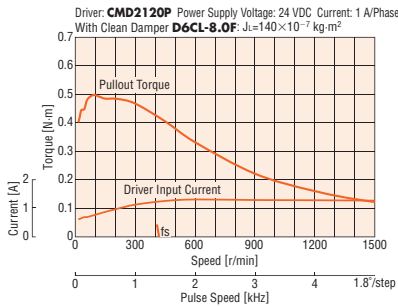

PKP266U10A2/PKP266U10B2

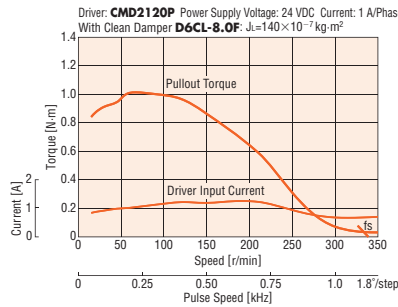

PKP268U10A2/PKP268U10B2

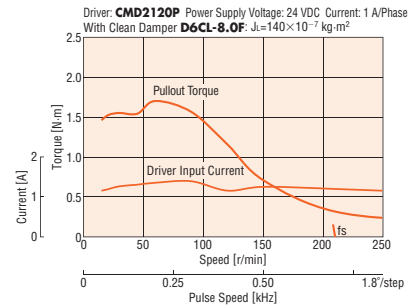

PKP264U20A2/PKP264U20B2

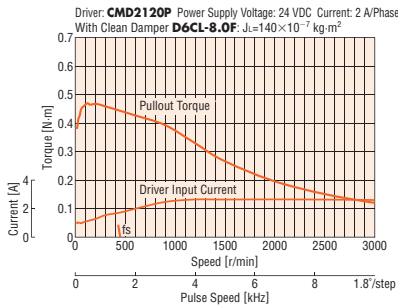

PKP266U20A2/PKP266U20B2

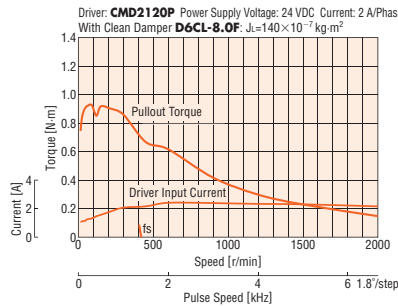

PKP268U20A2/PKP268U20B2

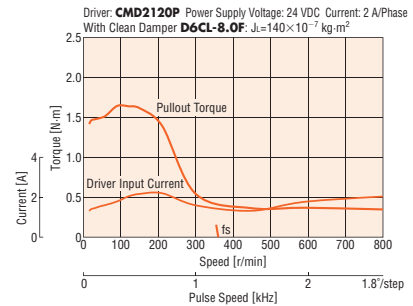

#### Note

- Data for the speed – torque characteristics is based on Oriental Motor's internal measurement conditions. If the conditions are changed, the characteristics may also change as a result.
- If there is a "clean damper" entry in the speed – torque characteristics, the data is for a double shaft motor when a clean damper is equipped.
- Depending on the driving conditions, a considerable amount of heat may be generated by the motor. Be sure to keep the motor case temperature at 100°C or less.

### Dimensions (Unit = mm)

#### ● Motor

Product Name	L1	L2	Mass kg
PKP264U10A2	39	—	0.45
PKP264U10B2		62	
PKP264U20A2	54	—	0.7
PKP264U20B2		62	
PKP266U10A2	54	—	0.7
PKP266U10B2		77	
PKP266U20A2	76	—	1.1
PKP266U20B2		77	
PKP268U10A2	76	—	1.1
PKP268U10B2		99	
PKP268U20A2	99	—	1.1
PKP268U20B2		99	

#### ● Applicable Connector

Connector Housing: MDF97-5S-3.5C (HIROSE ELECTRIC CO., LTD.)  
Contact: MDF97-22SC (HIROSE ELECTRIC CO., LTD.)  
Crimp Tool: HT801/MDF97-22S (HIROSE ELECTRIC CO., LTD.)

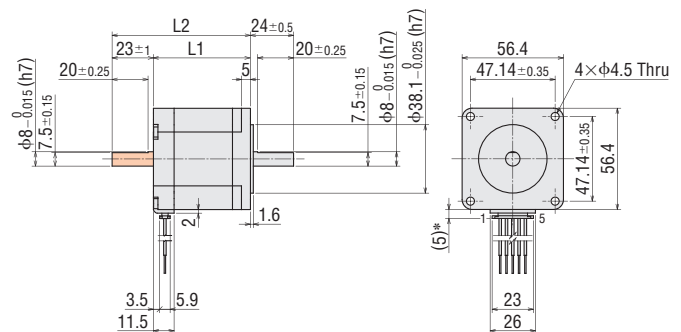

- \*With connection cable
- These dimensions are for double shaft motors. For single shaft motors, ignore the shaded areas.

#### ● Connection Cable (Sold separately)

##### ◇ For Motor

Product Name	Length L (m)
LC2U06E	0.6

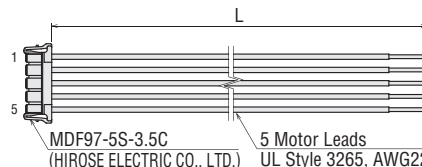

### Inner Wiring Diagram of Motor

Wiring Diagram No.: ④

- Refer to page A-431 for inner wiring diagram of motor.

Overview, Product Series

AC Input Motor & Driver

0.36°/Geared  
αSTEP Absolute AZ

0.36°/Geared  
αSTEP AR

0.72°/Geared  
RKII

DC Input Motor & Driver

0.36°/Geared  
αSTEP Absolute AZ

0.36°/Geared  
αSTEP AR

1.8°/0.72°/0.36°  
CVK

0.72°/0.36°/Geared  
CRK

1.8°/Geared  
RBK

Motor Only / Driver Only

1.8°/0.9°  
PKP/PK

Geared  
PKP/PK

0.72°/0.36°  
PKP/PK

Driver

Accessories



## Dimensions (Unit = mm)

### ● Motor

Product Name	L	Mass kg
PKP264D14A2-R2EL	55.5	0.45
PKP264D14A2-R2FL		
PKP264D28A2-R2EL		
PKP264D28A2-R2FL		
PKP264D42A2-R2EL	70.5	0.7
PKP264D42A2-R2FL		
PKP266D14A2-R2EL		
PKP266D14A2-R2FL		
PKP266D28A2-R2EL	92.5	1.1
PKP266D28A2-R2FL		
PKP266D42A2-R2EL		
PKP266D42A2-R2FL		

### ● Applicable Connector

	Motor (HIROSE ELECTRIC CO., LTD.)	Encoder (Molex)
Connector Housing	MDF97-5S-3.5C	51021-0800
Contact	MDF97-22SC	50079-8100
Crimp Tool	HT801/MDF97-22S	57067-3000

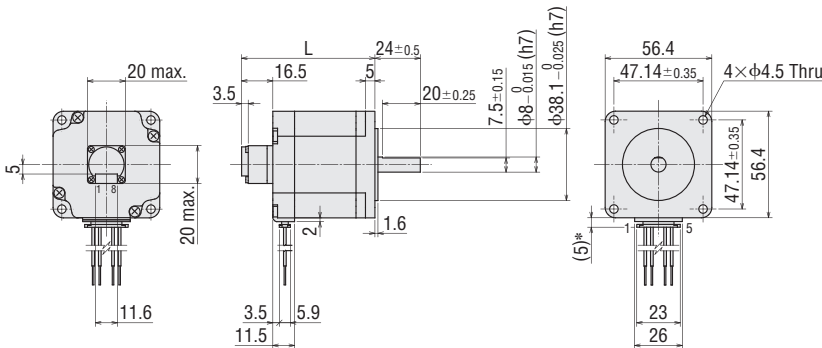

\*With connection cable

### ● Connection Cable (Sold separately)

#### ◇ For Motor

Product Name	Length L (m)
LC2B06E	0.6

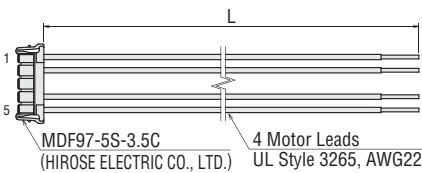

#### ◇ For Encoder

Product Name	Length L (m)
LCE08A-006	0.6

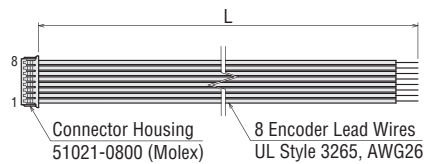

## Inner Wiring Diagram of Motor

Wiring Diagram No.: ①

● Refer to page A-431 for inner wiring diagram of motor.

Overview,  
Product  
Series

AC Input  
Motor &  
Driver

0.36°/Geared  
**αSTEP**  
Absolute  
**AZ**

0.36°/Geared  
**αSTEP**  
**AR**

0.72°/Geared  
**RKII**

DC Input  
Motor &  
Driver

0.36°/Geared  
**αSTEP**  
Absolute  
**AZ**

0.36°/Geared  
**αSTEP**  
**AR**

1.8°/0.72°  
/0.36°  
**CVK**

0.72°/0.36°  
/Geared  
**CRK**

1.8°/Geared  
**RBK**

Motor Only  
/Driver Only

1.8°/0.9°  
**PKP/PK**

Geared  
**PKP/PK**

0.72°/0.36°  
**PKP/PK**

Driver

Accessories

# Standard Type with Encoder Frame Size 56.4 mm (Unipolar 5 lead wires)

## Specifications

Product Name	Maximum Holding Torque N·m	Rotor Inertia J: kg·m <sup>2</sup>	Rated Current A/Phase	Voltage VDC	Winding Resistance Ω/Phase	Inductance mH/Phase	Basic Step Angle	Recommended Driver Product Name*	
<b>PKP264U10A2-R2EL</b>	0.58	140×10 <sup>-7</sup>	1	4.4	4.4	6	1.8°	<b>CMD2120P</b>	
<b>PKP264U10A2-R2FL</b>			2	2.2	1.1	1.5			
<b>PKP264U20A2-R2EL</b>	1.1	270×10 <sup>-7</sup>	1	6.9	6.9	11.6			
<b>PKP264U20A2-R2FL</b>			2	3.4	1.7	2.9			
<b>PKP266U10A2-R2EL</b>	2	500×10 <sup>-7</sup>	1	9.9	9.9	18.4			
<b>PKP266U10A2-R2FL</b>			2	4.8	2.4	4.6			
<b>PKP266U20A2-R2EL</b>									
<b>PKP266U20A2-R2FL</b>									

● Refer to page A-430 for encoder specifications.

\*Refer to page A-445 for details on the recommended driver.

## Speed – Torque Characteristics (Reference values)

**PKP264U10A2-R2EL**  
**PKP264U10A2-R2FL**

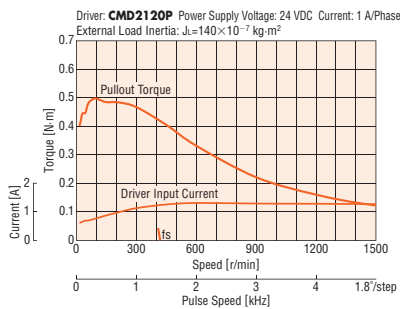

**PKP266U10A2-R2EL**  
**PKP266U10A2-R2FL**

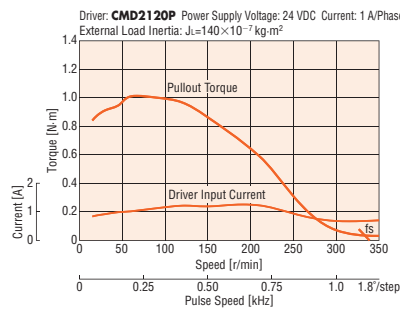

**PKP268U10A2-R2EL**  
**PKP268U10A2-R2FL**

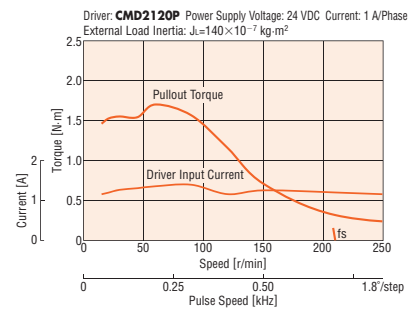

**PKP264U20A2-R2EL**  
**PKP264U20A2-R2FL**

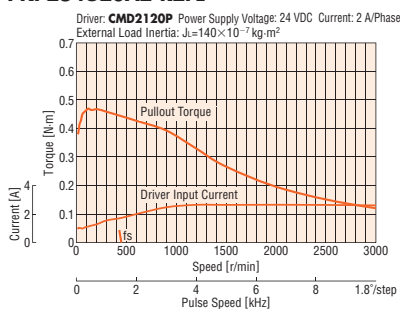

**PKP266U20A2-R2EL**  
**PKP266U20A2-R2FL**

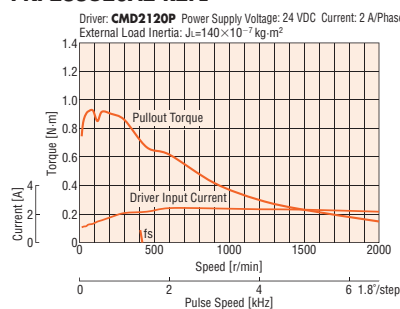

**PKP268U20A2-R2EL**  
**PKP268U20A2-R2FL**

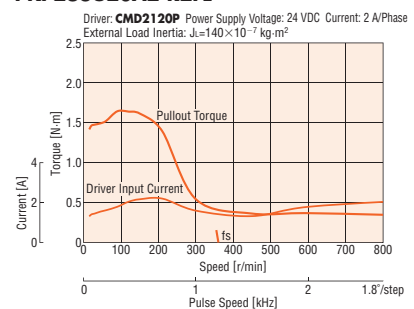

**Note**

- Data for the speed – torque characteristics is based on Oriental Motor's internal measurement conditions. If the conditions are changed, the characteristics may also change as a result.
- The data in the speed – torque characteristics represents the use of an external load inertia.
- Depending on the driving conditions, a considerable amount of heat may be generated by the motor. To protect the encoder, be sure to keep the motor case temperature at 85°C max.

## Dimensions (Unit = mm)

### ● Motor

Product Name	L	Mass kg
PKP264U10A2-R2EL	55.5	0.45
PKP264U10A2-R2FL		
PKP264U20A2-R2EL		
PKP264U20A2-R2FL	70.5	0.7
PKP266U10A2-R2EL		
PKP266U10A2-R2FL		
PKP266U20A2-R2EL	92.5	1.1
PKP266U20A2-R2FL		
PKP268U10A2-R2EL		
PKP268U10A2-R2FL		
PKP268U20A2-R2EL		
PKP268U20A2-R2FL		

### ● Applicable Connector

	Motor (HIROSE ELECTRIC CO., LTD.)	Encoder (Molex)
Connector Housing	MDF97-5S-3.5C	51021-0800
Contact	MDF97-22SC	50079-8100
Crimp Tool	HT801/MDF97-22S	57067-3000

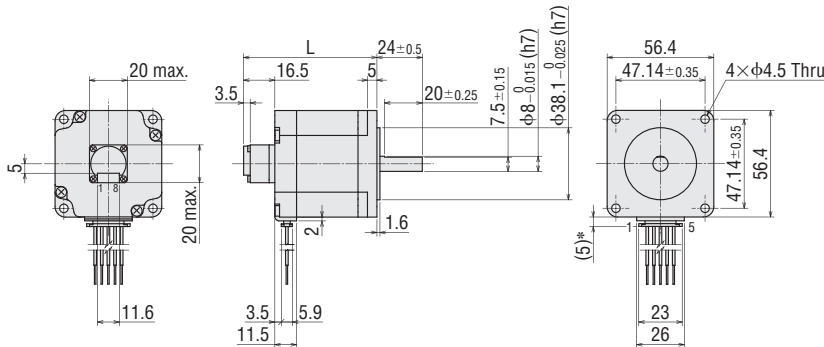

\*With Connection Cable

### ● Connection Cable (Sold separately)

#### ◇ For Motor

Product Name	Length L (m)
LC2U06E	0.6

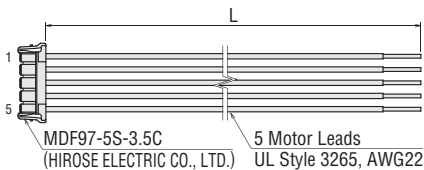

#### ◇ For Encoder

Product Name	Length L (m)
LCE08A-006	0.6

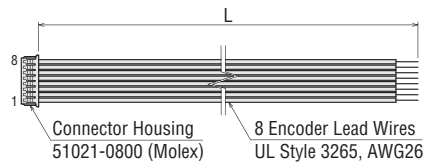

## Inner Wiring Diagram of Motor

Wiring Diagram No.: ④

● Refer to page A-431 for inner wiring diagram of motor.

Overview,  
Product  
Series

AC Input  
Motor &  
Driver

0.36°/Geared  
**αSTEP**  
Absolute  
**AZ**

0.36°/Geared  
**αSTEP**  
**AR**

0.72°/Geared  
**RKII**

DC Input  
Motor &  
Driver

0.36°/Geared  
**αSTEP**  
Absolute  
**AZ**

0.36°/Geared  
**αSTEP**  
**AR**

1.8°/0.72°  
/0.36°  
**CVK**

0.72°/0.36°  
/Geared  
**CRK**

1.8°/Geared  
**RBK**

Motor Only  
/Driver Only

1.8°/0.9°  
**PKP/PK**

Geared  
**PKP/PK**

0.72°/0.36°  
**PKP/PK**

Driver

Accessories

# Standard Type with Electromagnetic Brake

Frame Size 56.4 mm (Bipolar 4 lead wires)

## Specifications

Product Name	Maximum Holding Torque N·m	Rotor Inertia J: kg·m <sup>2</sup>	Rated Current A/Phase	Voltage VDC	Winding Resistance Ω/Phase	Inductance mH/Phase	Basic Step Angle	Electromagnetic Brake Static Friction Torque N·m
<b>PKP264D28M</b>	0.6	270×10 <sup>-7</sup>	2.8	2	0.73	1.8	1.8°	1.5
<b>PKP266D28M</b>	1.4	440×10 <sup>-7</sup>		2.8	1	2.9		
<b>PKP268D28M</b>	2.3	640×10 <sup>-7</sup>		3.4	1.23	4.4		

● Refer to page A-430 for electromagnetic brake specifications.

## Speed – Torque Characteristics (Reference values)

**PKP264D28M**

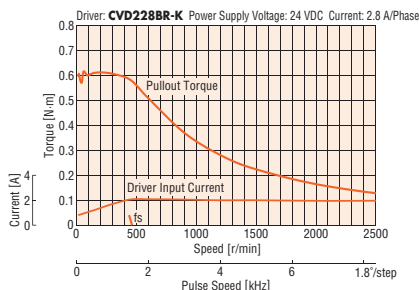

**PKP266D28M**

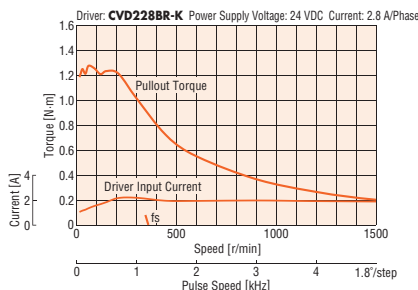

**PKP268D28M**

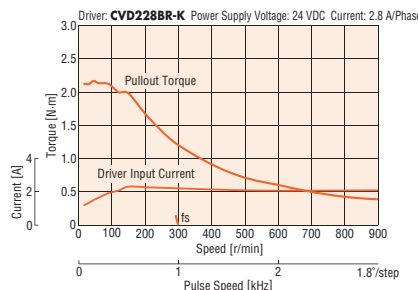

**Note**

- Data for the speed – torque characteristics is based on Oriental Motor's internal measurement conditions. If the conditions are changed, the characteristics may also change as a result.
- Depending on the driving conditions, a considerable amount of heat may be generated by the motor. Be sure to keep the motor case temperature at 100°C or less.

## Dimensions (Unit = mm)

● Motor

Product Name	L	Mass kg
<b>PKP264D28M</b>	75.5	0.76
<b>PKP266D28M</b>	90.5	1.03
<b>PKP268D28M</b>	112.5	1.4

- Applicable Connector (Molex)  
Connector Housing: 51067-0600  
Contact: 50217-9101  
Crimp Tool: 57189-5000  
57190-5000

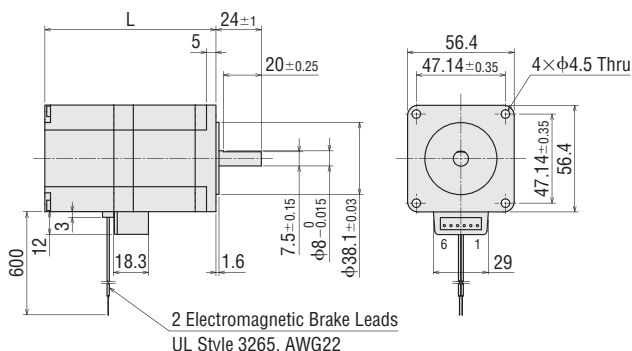

## Inner Wiring Diagram of Motor

Wiring Diagram No.: ②

- Refer to page A-431 for inner wiring diagram of motor.

● Connection Cable (Sold separately)

◇ For Motor

Product Name	Length L (m)
<b>LC2B06C</b>	0.6

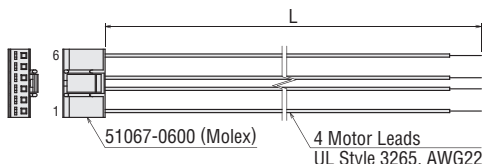

## Standard Type with Electromagnetic Brake

Frame Size 56.4 mm (Unipolar 6 lead wires)

### Specifications

Product Name	Maximum Holding Torque N·m	Rotor Inertia J: kg·m <sup>2</sup>	Rated Current A/Phase	Voltage VDC	Winding Resistance Ω/Phase	Inductance mH/Phase	Basic Step Angle	Electromagnetic Brake Static Friction Torque N·m
<b>PKP264U20M</b>	0.51	$270 \times 10^{-7}$	2	2.9	1.45	1.8	1.8°	1.5
<b>PKP266U20M</b>	1.1	$440 \times 10^{-7}$		4	2	2.9		
<b>PKP268U20M</b>	1.75	$640 \times 10^{-7}$		4.9	2.45	4.4		

● Refer to page A-430 for electromagnetic brake specifications.

### Speed – Torque Characteristics (Reference values)

**PKP264U20M**

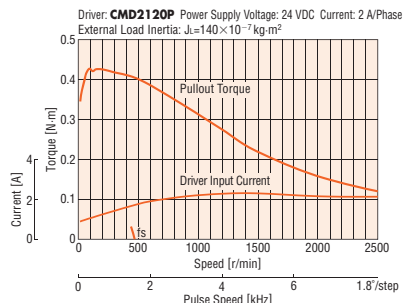

**PKP266U20M**

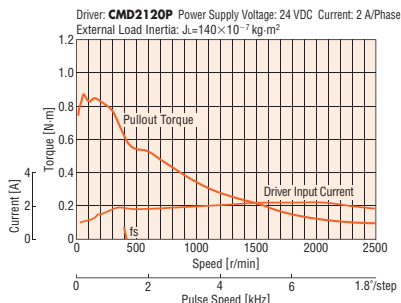

**PKP268U20M**

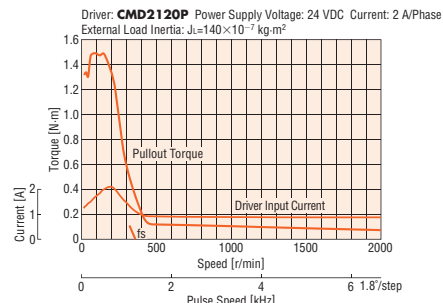

**Note**

- Data for the speed – torque characteristics is based on Oriental Motor's internal measurement conditions. If the conditions are changed, the characteristics may also change as a result.
- The data in the speed – torque characteristics represents the use of an external load inertia.
- Depending on the driving conditions, a considerable amount of heat may be generated by the motor. Be sure to keep the motor case temperature at 100°C or less.

### Dimensions (Unit = mm)

● Motor

Product Name	L	Mass kg
<b>PKP264U20M</b>	75.5	0.76
<b>PKP266U20M</b>	90.5	1.03
<b>PKP268U20M</b>	112.5	1.4

- Applicable Connector (Molex)  
Connector Housing: 51067-0600  
Contact: 50217-9101  
Crimp Tool: 57189-5000  
57190-5000

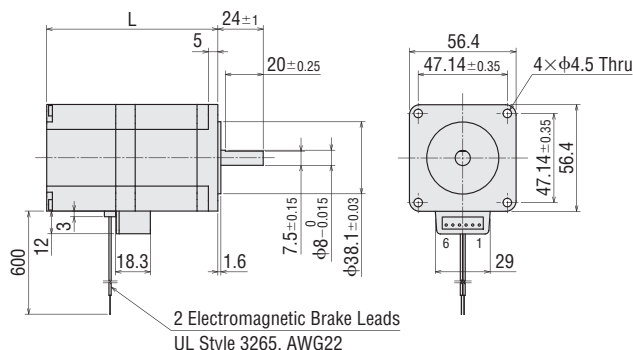

● Connection Cable (Sold separately)

◇ For Motor

Product Name	Length L (m)
<b>LC2U06C</b>	0.6
<b>LC2U10C</b>	1

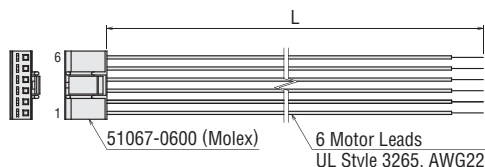

### Inner Wiring Diagram of Motor

Wiring Diagram No.: ⑥

● Refer to page A-431 for inner wiring diagram of motor.

Overview, Product Series

AC Input Motor & Driver

0.36°/Geared  
αSTEP Absolute AZ

0.36°/Geared  
αSTEP AR

0.72°/Geared  
RK II

DC Input Motor & Driver

0.36°/Geared  
αSTEP Absolute AZ

0.36°/Geared  
αSTEP AR

1.8°/0.72°/0.36°  
CVK

0.72°/0.36°/Geared  
CRK

1.8°/Geared  
RBK

Motor Only /Driver Only

1.8°/0.9°  
PKP/PK

Geared  
PKP/PK

0.72°/0.36°  
PKP/PK

Driver

Accessories

# Standard Type Frame Size 60 mm (Bipolar 4 lead wires)

## Specifications

Product Name	Maximum Holding Torque N·m	Rotor Inertia J: kg·m <sup>2</sup>	Rated Current A/Phase	Voltage VDC	Winding Resistance Ω/Phase	Inductance mH/Phase	Basic Step Angle
PK264JD□	1.06	280×10 <sup>-7</sup>	2.8	2.1	0.73	1.8	1.8°
PK266JD□	1.75	450×10 <sup>-7</sup>		2.8	1	3.05	
PK267JD□	2.2	570×10 <sup>-7</sup>		3.4	1.2	3.54	
PK269JD□	3.1	900×10 <sup>-7</sup>		4.2	1.49	5.7	

● Either **A** (Single Shaft) or **B** (Double Shaft) indicating the configuration is specified where the box □ is located in the product name.

## Speed – Torque Characteristics (Reference values)

**PK264JDA/PK264JDB**

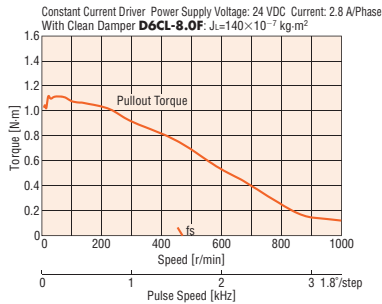

**PK266JDA/PK266JDB**

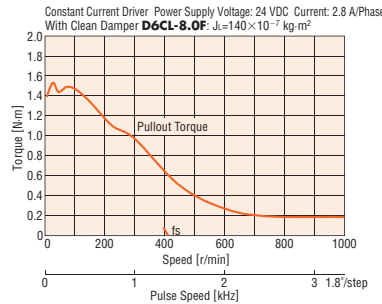

**PK267JDA/PK267JDB**

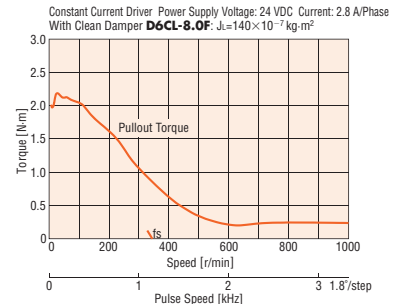

**PK269JDA/PK269JDB**

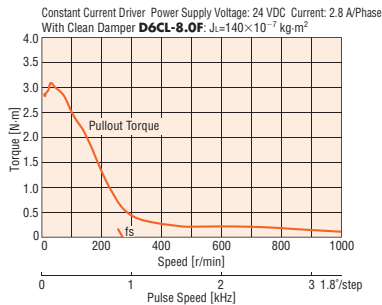

**Note**

- Data for the speed – torque characteristics is based on Oriental Motor's internal measurement conditions. If the conditions are changed, the characteristics may also change as a result.
- If there is a "clean damper" entry in the speed – torque characteristics, the data is for a double shaft motor when a clean damper is equipped.
- Depending on the driving conditions, a considerable amount of heat may be generated by the motor. Be sure to keep the motor case temperature at 100°C or less.

## Dimensions (Unit = mm)

● Motor

Product Name	L1	L2	Mass kg
PK264JDA	43.5	—	0.6
PK264JDB		66.5	
PK266JDA	54	—	0.83
PK266JDB		77	
PK267JDA	65	—	1.02
PK267JDB		88	
PK269JDA	85	—	1.43
PK269JDB		108	

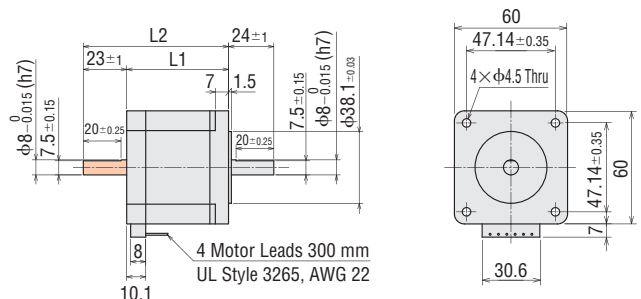

● These dimensions are for double shaft motors.  
For single shaft motors, ignore the shaded areas.

## Inner Wiring Diagram of Motor

Wiring Diagram No.: ③

- Refer to page A-431 for inner wiring diagram of motor.



## Standard Type Frame Size 60 mm (Unipolar 6 lead wires)

### Specifications

Product Name	Maximum Holding Torque N·m	Rotor Inertia J: kg·m <sup>2</sup>	Rated Current A/Phase	Voltage VDC	Winding Resistance Ω/Phase	Inductance mH/Phase	Basic Step Angle
PK264J□	0.75	$280 \times 10^{-7}$	2	2.9	1.46	1.8	1.8°
PK266J□	1.35	$450 \times 10^{-7}$		4	2	3.05	
PK267J□	1.7	$570 \times 10^{-7}$		4.8	2.4	3.54	
PK269J□	2.2	$900 \times 10^{-7}$		6	2.98	5.7	

● Either **A** (Single Shaft) or **B** (Double Shaft) indicating the configuration is specified where the box □ is located in the product name.

### Speed – Torque Characteristics (Reference values)

#### PK264JA/PK264JB

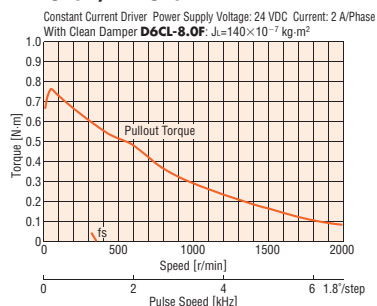

#### PK266JA/PK266JB

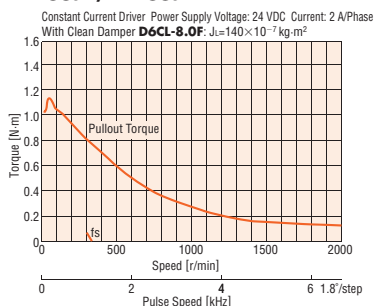

#### PK267JA/PK267JB

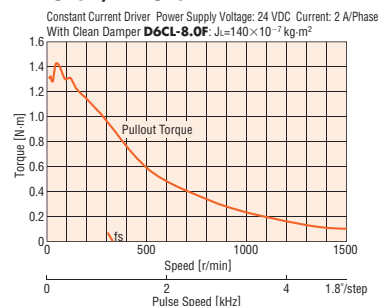

#### PK269JA/PK269JB

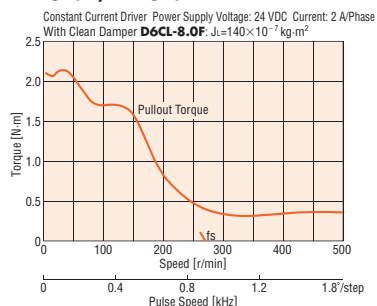

#### Note

- Data for the speed – torque characteristics is based on Oriental Motor's internal measurement conditions. If the conditions are changed, the characteristics may also change as a result.
- If there is a "clean damper" entry in the speed – torque characteristics, the data is for a double shaft motor when a clean damper is equipped.
- Depending on the driving conditions, a considerable amount of heat may be generated by the motor. Be sure to keep the motor case temperature at 100°C or less.

### Dimensions (Unit = mm)

#### Motor

Product Name	L1	L2	Mass kg
PK264JA	43.5	–	0.6
PK264JB		66.5	
PK266JA	54	–	0.83
PK266JB		77	
PK267JA	65	–	1.02
PK267JB		88	
PK269JA	85	–	1.43
PK269JB		108	

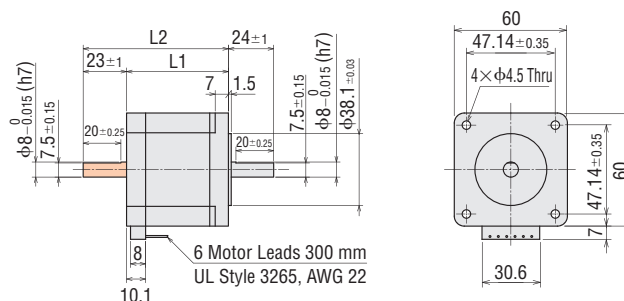

- These dimensions are for double shaft motors.  
For single shaft motors, ignore the shaded areas.

### Inner Wiring Diagram of Motor

Wiring Diagram No.: ①

- Refer to page A-431 for inner wiring diagram of motor.

Overview,  
Product  
Series

AC Input  
Motor &  
Driver

0.36°/Geared  
Absolute  
AZ

0.36°/Geared  
AR

0.72°/Geared  
RK II

DC Input  
Motor &  
Driver

0.36°/Geared  
Absolute  
AZ

0.36°/Geared  
AR

1.8°/0.72°  
/0.36°  
CVK

0.72°/0.36°  
/Geared  
CRK

1.8°/Geared  
RBK

Motor Only  
/Driver Only

1.8°/0.9°  
PKP/PK

Geared  
PKP/PK

0.72°/0.36°  
PKP/PK

Driver

Accessories

# Standard Type Frame Size 85 mm (Bipolar 4 lead wires)

## Specifications

Product Name	Maximum Holding Torque N·m	Rotor Inertia J: kg·m <sup>2</sup>	Rated Current A/Phase	Voltage VDC	Winding Resistance Ω/Phase	Inductance mH/Phase	Basic Step Angle	Recommended Driver Product Name*
PKP296D45□	3.3	1100×10 <sup>-7</sup>	4.5	1.9	0.42	3.1	1.8°	CVD245BR-K
PKP296D63□			6.3	1.4	0.23	1.6		-
PKP299D45□	6.4	2200×10 <sup>-7</sup>	4.5	2.7	0.6	5.4		CVD245BR-K
PKP299D63□			6.3	2	0.32	2.6		-
PKP2913D45□	9.5	3400×10 <sup>-7</sup>	4.5	3.5	0.78	6.9		CVD245BR-K
PKP2913D56□			5.6	2.6	0.47	4.4		-

● Either **A** (Single Shaft) or **B** (Double Shaft) indicating the configuration is specified where the box □ is located in the product name.

\*Refer to page A-439 for details on the recommended driver.

## Speed – Torque Characteristics (Reference values)

**PKP296D45A/PKP296D45B**

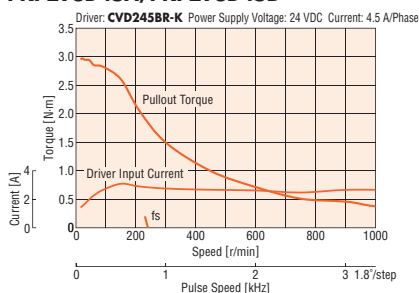

**PKP299D45A/PKP299D45B**

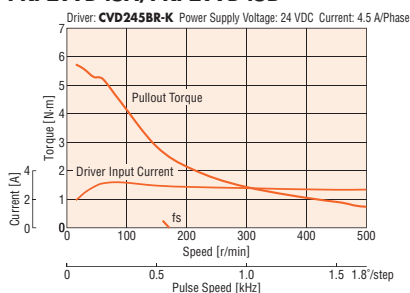

**PKP2913D45A/PKP2913D45B**

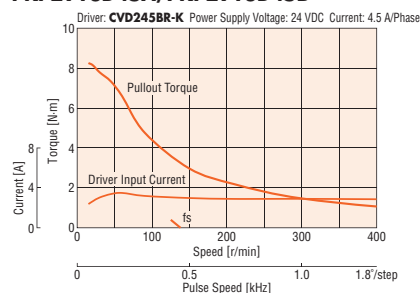

**PKP296D63A/PKP296D63B**

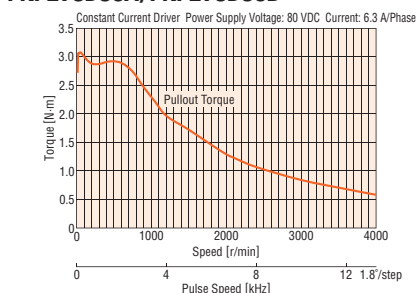

**PKP299D63A/PKP299D63B**

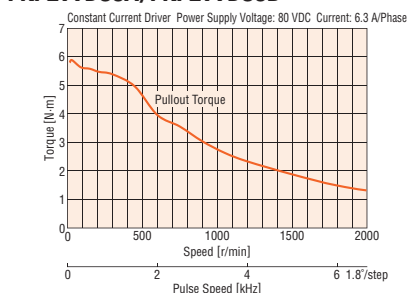

**PKP2913D56A/PKP2913D56B**

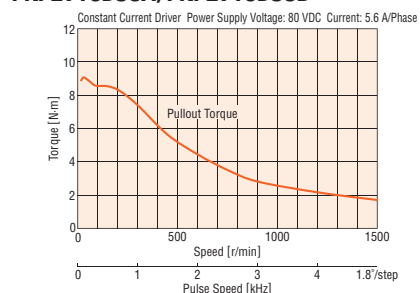

**Note**

- Data for the speed – torque characteristics is based on Oriental Motor's internal measurement conditions. If the conditions are changed, the characteristics may also change as a result.
- Depending on the driving conditions, a considerable amount of heat may be generated by the motor. Be sure to keep the motor case temperature at 100°C or less.

## Dimensions (Unit = mm)

### Motor

Product Name	L1	L2	Mass kg
PKP296D45A	66	-	1.8
PKP296D45B		100	
PKP296D63A		-	
PKP296D63B	96	100	2.9
PKP299D45A		-	
PKP299D45B		130	
PKP299D63A	126	-	4
PKP299D63B		130	
PKP2913D45A		-	
PKP2913D45B	126	160	4
PKP2913D56A		-	
PKP2913D56B		160	

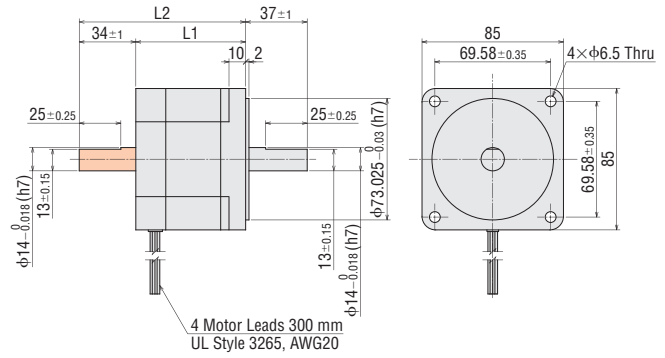

● These dimensions are for double shaft motors.  
For single shaft motors, ignore the shaded areas.

## Inner Wiring Diagram of Motor

Wiring Diagram No.: ③

● Refer to page A-431 for inner wiring diagram of motor.

Overview, Product Series

AC Input Motor & Driver

0.36°/Geared  
αSTEP Absolute  
AZ

0.36°/Geared  
αSTEP AR

0.72°/Geared  
RK II

DC Input Motor & Driver

0.36°/Geared  
αSTEP Absolute  
AZ

0.36°/Geared  
αSTEP AR

1.8°/0.72°  
/0.36°  
CVK

0.72°/0.36°  
/Geared  
CRK

1.8°/Geared  
RBK

Motor Only /Driver Only

1.8°/0.9°  
PKP/PK

Geared  
PKP/PK

0.72°/0.36°  
PKP/PK

Driver

Accessories

# Standard Type Frame Size 85 mm (Unipolar 6 lead wires)

## Specifications

Product Name	Maximum Holding Torque N·m	Rotor Inertia J: kg·m <sup>2</sup>	Rated Current A/Phase	Voltage VDC	Winding Resistance Ω/Phase	Inductance mH/Phase	Basic Step Angle
PKP296U20□	2.6	1100×10 <sup>-7</sup>	2	4.4	2.2	7.8	1.8°
PKP296U30□			3	3	1.0	3.5	
PKP296U45□			4.5	2	0.45	1.6	
PKP299U20□	5.0	2200×10 <sup>-7</sup>	2	6.4	3.2	13.2	
PKP299U30□			3	4.5	1.5	6	
PKP299U45□			4.5	2.8	0.63	2.6	
PKP2913U20□	7.3	3400×10 <sup>-7</sup>	2	7.6	3.8	18	
PKP2913U40□			4	3.8	0.94	4.4	

● Either **A** (Single Shaft) or **B** (Double Shaft) indicating the configuration is specified where the box □ is located in the product name.

## Speed – Torque Characteristics (Reference values)

**PKP296U20A/PKP296U20B**

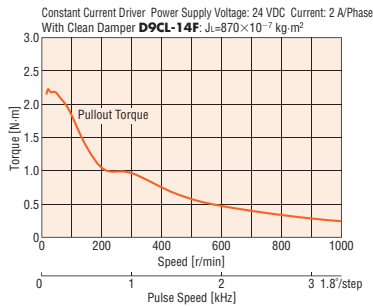

**PKP299U20A/PKP299U20B**

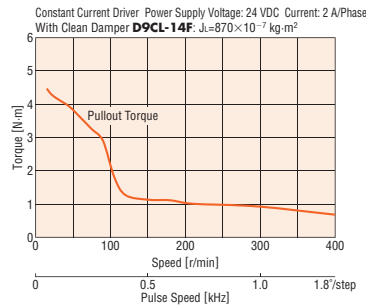

**PKP2913U20A/PKP2913U20B**

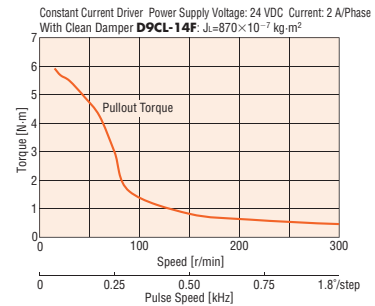

**PKP296U30A/PKP296U30B**

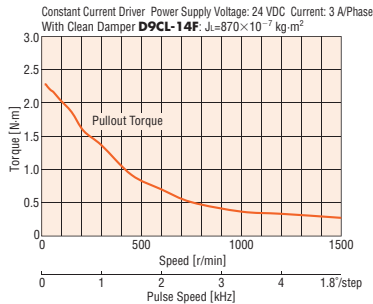

**PKP299U30A/PKP299U30B**

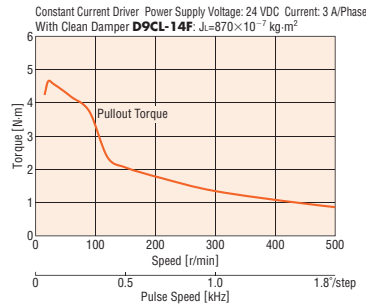

**PKP2913U40A/PKP2913U40B**

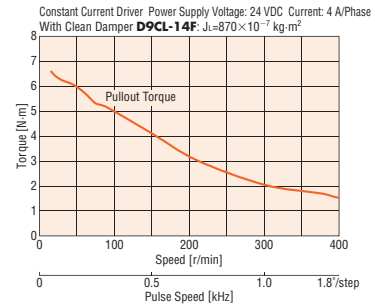

**PKP296U45A/PKP296U45B**

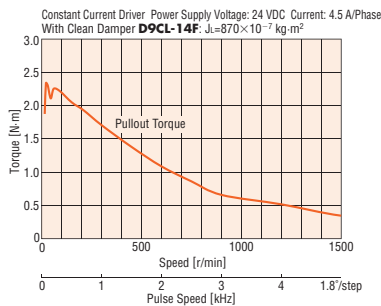

**PKP299U45A/PKP299U45B**

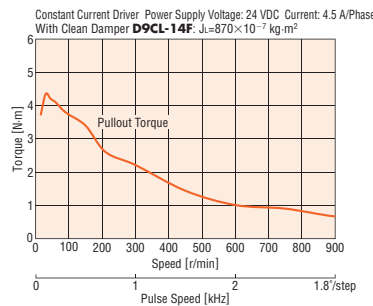

**Note**

- Data for the speed – torque characteristics is based on Oriental Motor's internal measurement conditions. If the conditions are changed, the characteristics may also change as a result.
- If there is a "clean damper" entry in the speed – torque characteristics, the data is for a double shaft motor when a clean damper is equipped.
- Depending on the driving conditions, a considerable amount of heat may be generated by the motor. Be sure to keep the motor case temperature at 100°C or less.

## Dimensions (Unit = mm)

### Motor

Product Name	L1	L2	Mass kg
PKP296U20A	66	-	1.8
PKP296U20B		100	
PKP296U30A		-	
PKP296U30B		100	
PKP296U45A		-	
PKP296U45B	100		
PKP299U20A	96	-	2.9
PKP299U20B		130	
PKP299U30A		-	
PKP299U30B		130	
PKP299U45A		-	
PKP299U45B	130		
PKP2913U20A	126	-	4
PKP2913U20B		160	
PKP2913U40A		-	
PKP2913U40B		160	

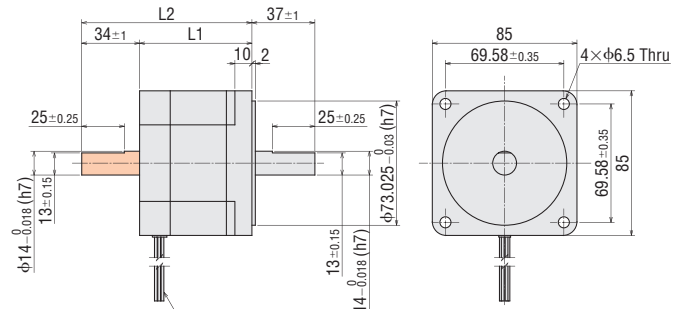

● These dimensions are for double shaft motors.  
For single shaft motors, ignore the shaded areas.

## Inner Wiring Diagram of Motor

Wiring Diagram No.: ⑦

● Refer to page A-431 for inner wiring diagram of motor.

Overview, Product Series

AC Input Motor & Driver

0.36°/Geared  
**αSTEP Absolute AZ**

0.36°/Geared  
**αSTEP AR**

0.72°/Geared  
**RK II**

DC Input Motor & Driver

0.36°/Geared  
**αSTEP Absolute AZ**

0.36°/Geared  
**αSTEP AR**

1.8°/0.72° / 0.36°  
**CVK**

0.72°/0.36° / Geared  
**CRK**

1.8°/Geared  
**RBK**

Motor Only / Driver Only

1.8°/0.9°  
**PKP/PK**

Geared  
**PKP/PK**

0.72°/0.36°  
**PKP/PK**

Driver

Accessories

# High-Resolution Type Frame Size 42 mm (Bipolar 4 lead wires)

## Specifications

Product Name	Maximum Holding Torque N·m	Rotor Inertia J: kg·m <sup>2</sup>	Rated Current A/Phase	Voltage VDC	Winding Resistance Ω/Phase	Inductance mH/Phase	Basic Step Angle	Recommended Driver Product Name*
PKP243MD15□	0.30	$36 \times 10^{-7}$	1.5	2.85	1.9	6.6	0.9°	CVD215BR-K
PKP244MD15□	0.42	$57 \times 10^{-7}$		3.9	2.6	7.6		

● Either **A** (single shaft) or **B** (double shaft) indicating the configuration is specified where the box □ is located in the product name.  
\*Refer to page A-439 for details on the recommended driver.

## Speed – Torque Characteristics (Reference values)

PKP243MD15A/PKP243MD15B

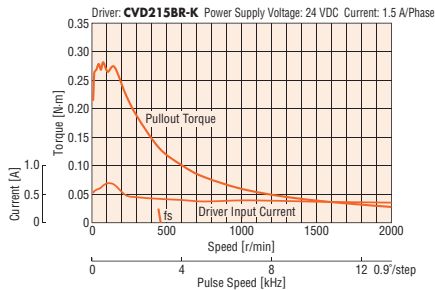

PKP244MD15A/PKP244MD15B

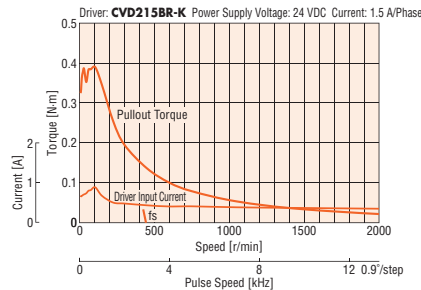

### Note

- Data for the speed – torque characteristics is based on Oriental Motor's internal measurement conditions. If the conditions are changed, the characteristics may also change as a result.
- Depending on the driving conditions, a considerable amount of heat may be generated by the motor. Be sure to keep the motor case temperature at 100°C or less.

## Dimensions (Unit = mm)

### Motor

Product Name	L1	L2	Mass kg
PKP243MD15A	33	—	0.25
PKP243MD15B		48	
PKP244MD15A	39	—	0.3
PKP244MD15B		54	

- Applicable Connector  
Connector housing: 51103-0600 (Molex)  
Contact: 50351-8100 (Molex)  
Crimp tool: 57295-5000 (Molex)

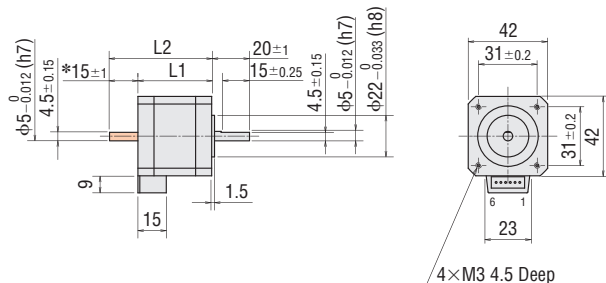

- \*The length of the shaft flat on the double shaft model is 15 ± 0.25.
- These dimensions are for double shaft motors.  
For single shaft motors, ignore the shaded areas.

### Connection Cable (Sold separately)

#### ◇ For Motor

Product Name	Length L (m)
LC2B06B	0.6

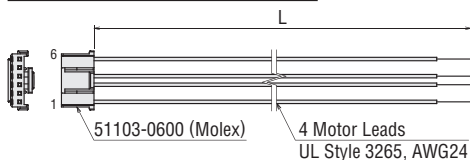

## Inner Wiring Diagram of Motor

Wiring Diagram No.: ②

- Refer to page A-431 for inner wiring diagram of motor.

## High-Resolution Type Frame Size 42 mm (Unipolar 6 lead wires)

### Specifications

Product Name	Maximum Holding Torque N·m	Rotor Inertia J: kg·m <sup>2</sup>	Rated Current A/Phase	Voltage VDC	Winding Resistance Ω/Phase	Inductance mH/Phase	Basic Step Angle	Recommended Driver Product Name*
PKP243MU09□	0.25	$36 \times 10^{-7}$	0.95	4.47	4.7	6.6	0.9°	<b>CMD2109P</b>
PKP244MU12□	0.35	$57 \times 10^{-7}$	1.2	4.8	4	6		<b>CMD2112P</b>

● Either **A** (single shaft) or **B** (double shaft) indicating the configuration is specified where the box □ is located in the product name.

\*Refer to page A-445 for details on the recommended driver.

### Speed – Torque Characteristics (Reference values)

**PKP243MU09A/PKP243MU09B**

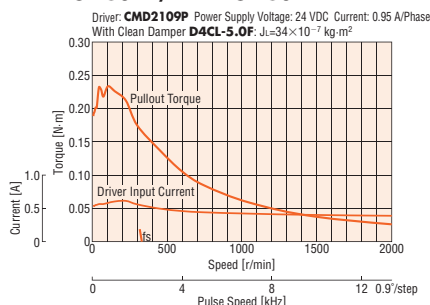

**PKP244MU12A/PKP244MU12B**

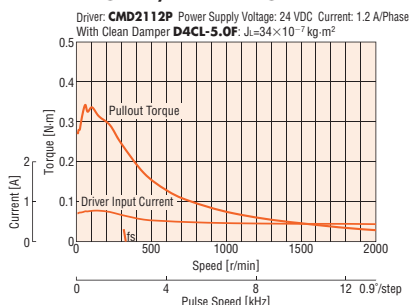

**Note**

- Data for the speed – torque characteristics is based on Oriental Motor's internal measurement conditions. If the conditions are changed, the characteristics may also change as a result.
- If there is a "clean damper" entry in the speed – torque characteristics, the data is for a double shaft motor when a clean damper is equipped.
- Depending on the driving conditions, a considerable amount of heat may be generated by the motor. Be sure to keep the motor case temperature at 100°C or less.

### Dimensions (Unit = mm)

● Motor

Product Name	L1	L2	Mass kg
PKP243MU09A	33	–	0.25
PKP243MU09B		48	
PKP244MU12A	39	–	0.3
PKP244MU12B		54	

- Applicable Connector  
Connector housing: 51103-0600 (Molex)  
Contact: 50351-8100 (Molex)  
Crimp tool: 57295-5000 (Molex)

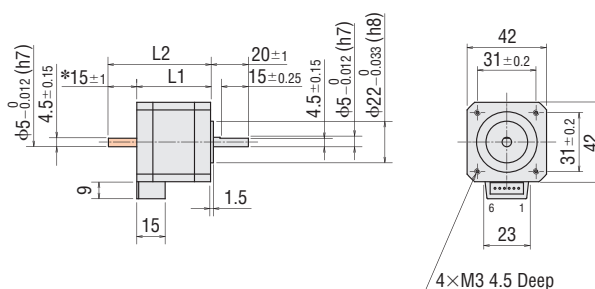

- \*The length of the shaft flat on the double shaft model is  $15 \pm 0.25$ .
- These dimensions are for double shaft motors.  
For single shaft motors, ignore the shaded areas.

● Connection Cable (Sold separately)

◇ For Motor

Product name	Length L (m)
LC2U06B	0.6
LC2U10B	1

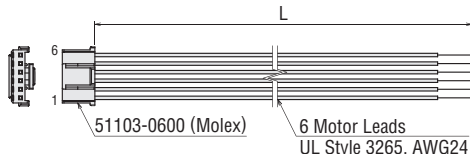

### Inner Wiring Diagram of Motor

Wiring Diagram No.: ⑥

- Refer to page A-431 for inner wiring diagram of motor.

Overview,  
Product  
Series

AC Input  
Motor &  
Driver

0.36°/Geared  
**αSTEP**  
Absolute  
**AZ**

0.36°/Geared  
**αSTEP**  
**AR**

0.72°/Geared  
**RKII**

DC Input  
Motor &  
Driver

0.36°/Geared  
**αSTEP**  
Absolute  
**AZ**

0.36°/Geared  
**αSTEP**  
**AR**

1.8°/0.72°  
/0.36°  
**CVK**

0.72°/0.36°  
/Geared  
**CRK**

1.8°/Geared  
**RBK**

Motor Only  
/Driver Only

1.8°/0.9°  
**PKP/PK**

Geared  
**PKP/PK**

0.72°/0.36°  
**PKP/PK**

Driver

Accessories

# High-Resolution Type with Encoder

Frame Size 42 mm (Bipolar 4 lead wires)

## Specifications

Product Name	Maximum Holding Torque N·m	Rotor Inertia J: kg·m <sup>2</sup>	Rated Current A/Phase	Voltage VDC	Winding Resistance Ω/Phase	Inductance mH/Phase	Basic Step Angle	Recommended Driver Product Name*
<b>PKP243MD15A-R2FL</b>	0.30	$36 \times 10^{-7}$	1.5	2.85	1.9	6.6	0.9°	<b>CVD215BR-K</b>
<b>PKP244MD15A-R2FL</b>	0.42	$57 \times 10^{-7}$		3.9	2.6	7.6		

● Refer to page A-430 for encoder specifications.

\*Refer to page A-439 for details on the recommended driver.

## Speed – Torque Characteristics (Reference values)

**PKP243MD15A-R2FL**

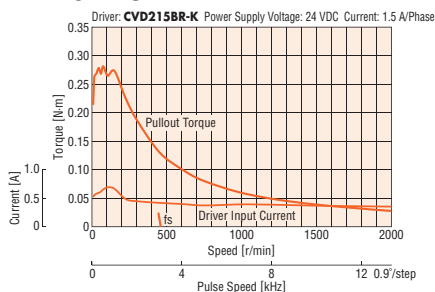

**PKP244MD15A-R2FL**

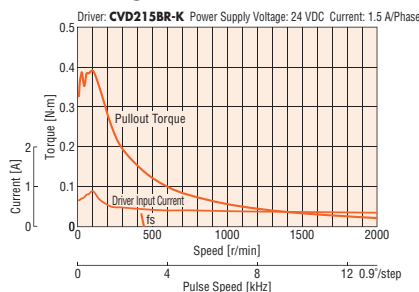

**Note**

- Data for the speed – torque characteristics is based on Oriental Motor's internal measurement conditions. If the conditions are changed, the characteristics may also change as a result.
- Depending on the driving conditions, a considerable amount of heat may be generated by the motor. To protect the encoder, be sure to keep the motor case temperature at 85°C max.

## Dimensions (Unit = mm)

### Motor

Product Name	L	Mass kg
<b>PKP243MD15A-R2FL</b>	46.5	0.26
<b>PKP244MD15A-R2FL</b>	52.5	0.31

● Applicable Connector (Molex)

	Motor	Encoder
Connector Housing	51103-0600	51021-0800
Contact	50351-8100	50079-8100
Crimp Tool	57295-5000	57067-3000

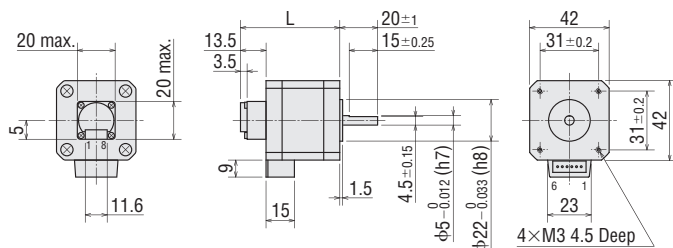

### Connection Cable (Sold separately)

#### ◇ For Motor

Product Name	Length L (m)
<b>LC2B06B</b>	0.6

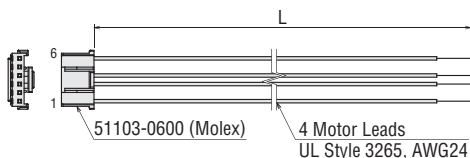

#### ◇ For Encoder

Product Name	Length L (m)
<b>LCE08A-006</b>	0.6

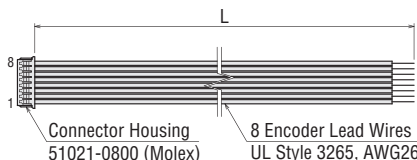

## Inner Wiring Diagram of Motor

Wiring Diagram No.: ②

● Refer to page A-431 for inner wiring diagram of motor.



## High-Resolution Type with Encoder

Frame Size 42 mm (Unipolar 6 lead wires)

### Specifications

Product Name	Maximum Holding Torque N·m	Rotor Inertia J: kg·m <sup>2</sup>	Rated Current A/Phase	Voltage VDC	Winding Resistance Ω/Phase	Inductance mH/Phase	Basic Step Angle	Recommended Driver Product Name*
<b>PKP243MU09A-R2FL</b>	0.25	36×10 <sup>-7</sup>	0.95	4.47	4.7	6.6	0.9°	<b>CMD2109P</b>
<b>PKP244MU12A-R2FL</b>	0.35	57×10 <sup>-7</sup>	1.2	4.8	4	6		<b>CMD2112P</b>

● Refer to page A-430 for encoder specifications.

\*Refer to page A-445 for details on the recommended driver.

### Speed – Torque Characteristics (Reference values)

**PKP243MU09A-R2FL**

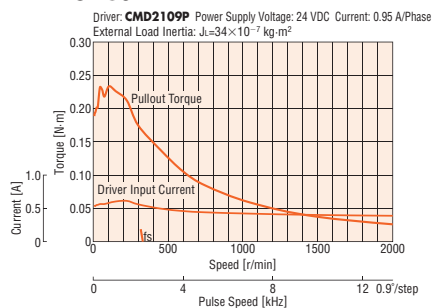

**PKP244MU12A-R2FL**

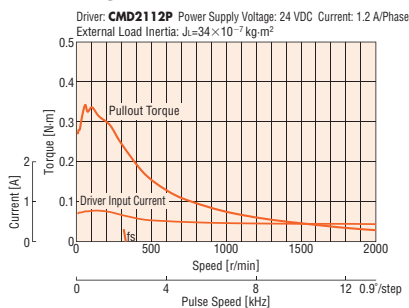

**Note**

- Data for the speed – torque characteristics is based on Oriental Motor's internal measurement conditions. If the conditions are changed, the characteristics may also change as a result.
- The data in the speed – torque characteristics represents the use of an external load inertia.
- Depending on the driving conditions, a considerable amount of heat may be generated by the motor. To protect the encoder, be sure to keep the motor case temperature at 85°C max.

### Dimensions (Unit = mm)

● Motor

Product Name	L	Mass kg
<b>PKP243MU09A-R2FL</b>	46.5	0.26
<b>PKP244MU12A-R2FL</b>	52.5	0.31

● Applicable Connector (Molex)

	Motor	Encoder
Connector Housing	51103-0600	51021-0800
Contact	50351-8100	50079-8100
Crimp Tool	57295-5000	57067-3000

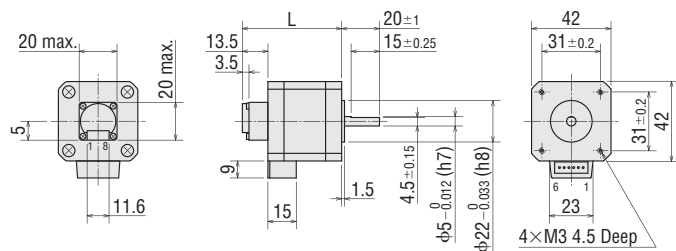

● Connection Cable (Sold separately)

◇ For Motor

Product Name	Length L (m)
<b>LC2U06B</b>	0.6
<b>LC2U10B</b>	1

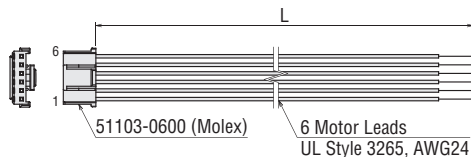

◇ For Encoder

Product Name	Length L (m)
<b>LCE08A-006</b>	0.6

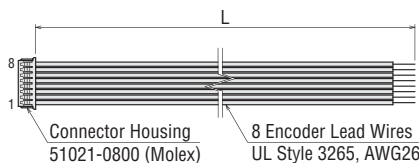

### Inner Wiring Diagram of Motor

Wiring Diagram No.: ⑥

- Refer to page A-431 for inner wiring diagram of motor.

Overview,  
Product  
Series

AC Input  
Motor &  
Driver

0.36°/Geared  
**αSTEP**  
Absolute  
**AZ**

0.36°/Geared  
**αSTEP**  
**AR**

0.72°/Geared  
**RKII**

DC Input  
Motor &  
Driver

0.36°/Geared  
**αSTEP**  
Absolute  
**AZ**

0.36°/Geared  
**αSTEP**  
**AR**

1.8°/0.72°  
/0.36°  
**CVK**

0.72°/0.36°  
/Geared  
**CRK**

1.8°/Geared  
**RBK**

Motor Only  
/Driver Only

1.8°/0.9°  
**PKP/PK**

Geared  
**PKP/PK**

0.72°/0.36°  
**PKP/PK**

Driver

Accessories

# High-Resolution Type with Electromagnetic Brake

## Frame Size 42 mm (Bipolar 4 lead wires)

### Specifications

Product Name	Maximum Holding Torque N·m	Rotor Inertia J: kg·m <sup>2</sup>	Rated current A/Phase	Voltage VDC	Winding Resistance Ω/Phase	Inductance mH/Phase	Basic Step Angle	Electromagnetic Brake Static Friction Torque N·m
<b>PKP243MD15M</b>	0.30	$48 \times 10^{-7}$	1.5	2.85	1.9	6.6	0.9°	0.3
<b>PKP244MD15M</b>	0.42	$69 \times 10^{-7}$		3.9	2.6	7.6		

● Refer to page A-430 for electromagnetic brake specifications.

### Speed – Torque Characteristics (Reference values)

**PKP243MD15M**

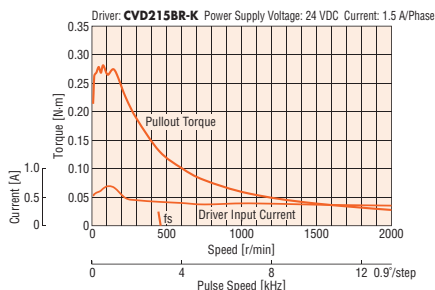

**PKP244MD15M**

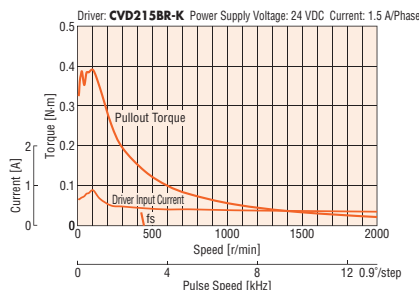

**Note**

- Data for the speed – torque characteristics is based on Oriental Motor's internal measurement conditions. If the conditions are changed, the characteristics may also change as a result.
- Depending on the driving conditions, a considerable amount of heat may be generated by the motor. Be sure to keep the motor case temperature at 100°C or less.

### Dimensions (Unit = mm)

● Motor

Product name	L	Mass kg
<b>PKP243MD15M</b>	67	0.36
<b>PKP244MD15M</b>	73	0.41

● Applicable Connector (Molex)

Connector housing: 51103-0600  
Contact: 50351-8100  
Crimp tool: 57295-5000

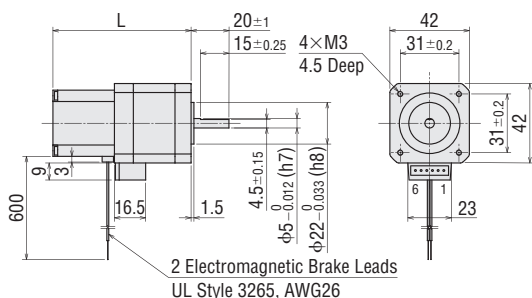

● Connection Cable (Sold separately)

◇ For Motor

Product Name	Length L (m)
<b>LC2B06B</b>	0.6

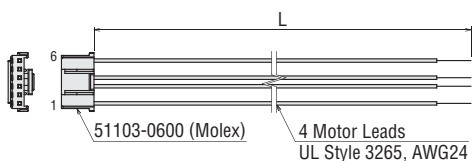

### Inner Wiring Diagram of Motor

Wiring Diagram No.: ②

- Refer to page A-431 for inner wiring diagram of motor.

## High-Resolution Type with Electromagnetic Brake

Frame Size 42 mm (Unipolar 6 lead wires)

### Specifications

Product Name	Maximum Holding Torque N·m	Rotor Inertia J: kg·m <sup>2</sup>	Rated Current A/Phase	Voltage VDC	Winding Resistance Ω/Phase	Inductance mH/Phase	Basic Step Angle	Electromagnetic Brake Static Friction Torque N·m
<b>PKP243MU09M</b>	0.25	$48 \times 10^{-7}$	0.95	4.47	4.7	6.6	0.9°	0.3
<b>PKP244MU12M</b>	0.35	$69 \times 10^{-7}$	1.2	4.8	4	6		

● Refer to page A-430 for electromagnetic brake specifications.

### Speed – Torque Characteristics (Reference values)

**PKP243MU09M**

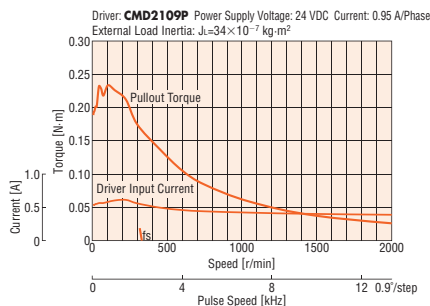

**PKP244MU12M**

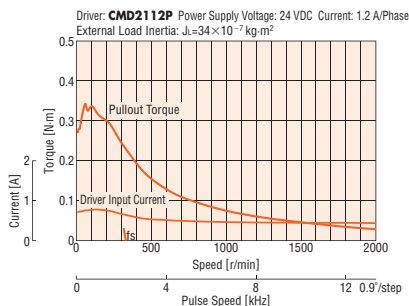

**Note**

- Data for the speed – torque characteristics is based on Oriental Motor's internal measurement conditions. If the conditions are changed, the characteristics may also change as a result.
- The data in the speed – torque characteristics represents the use of an external load inertia.
- Depending on the driving conditions, a considerable amount of heat may be generated by the motor. Be sure to keep the motor case temperature at 100°C or less.

### Dimensions (Unit = mm)

● Motor

Product Name	L	Mass kg
<b>PKP243MU09M</b>	67	0.36
<b>PKP244MU12M</b>	73	0.41

- Applicable Connector (Molex)  
Connector housing: 51103-0600  
Contact: 50351-8100  
Crimp tool: 57295-5000

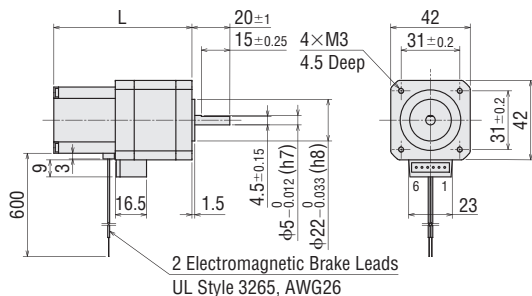

● Connection Cable (Sold separately)

◇ For Motor

Product Name	Length L (m)
<b>LC2U06B</b>	0.6
<b>LC2U10B</b>	1

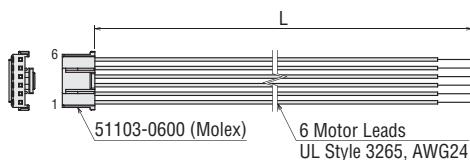

### Inner Wiring Diagram of Motor

Wiring Diagram No.: ⑥

- Refer to page A-431 for inner wiring diagram of motor.

Overview,  
Product  
Series

AC Input  
Motor &  
Driver

0.36°/Geared  
**αSTEP**  
Absolute  
**AZ**

0.36°/Geared  
**αSTEP**  
**AR**

0.72°/Geared  
**RKII**

DC Input  
Motor &  
Driver

0.36°/Geared  
**αSTEP**  
Absolute  
**AZ**

0.36°/Geared  
**αSTEP**  
**AR**

1.8°/0.72°  
/0.36°  
**CVK**

0.72°/0.36°  
/Geared  
**CRK**

1.8°/Geared  
**RBK**

Motor Only  
/Driver Only

1.8°/0.9°  
**PKP/PK**

Geared  
**PKP/PK**

0.72°/0.36°  
**PKP/PK**

Driver

Accessories

# High-Resolution Type Frame Size 56.4 mm (Bipolar 4 lead wires)

## Specifications

Product Name	Maximum Holding Torque N·m	Rotor Inertia J: kg·m <sup>2</sup>	Rated Current A/Phase	Voltage VDC	Winding Resistance Ω/Phase	Inductance mH/Phase	Basic Step Angle	Recommended Driver Product Name*
PKP264MD28□	0.6	120×10 <sup>-7</sup>	2.8	2	0.73	2.1	0.9°	CVD228BR-K
PKP266MD28□	1.32	290×10 <sup>-7</sup>		2.8	1	3.9		
PKP268MD28□	2.23	490×10 <sup>-7</sup>		3.4	1.23	5.6		

● Either **A** (single shaft) or **B** (double shaft) indicating the configuration is specified where the box □ is located in the product name.  
\*Refer to page A-439 for details on the recommended driver.

## Speed – Torque Characteristics (Reference values)

PKP264MD28A/PKP264MD28B

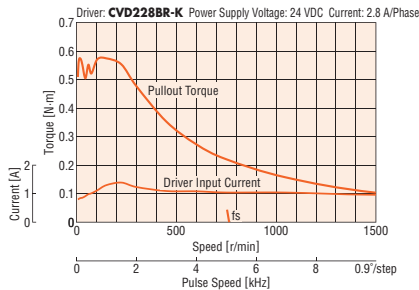

PKP266MD28A/PKP266MD28B

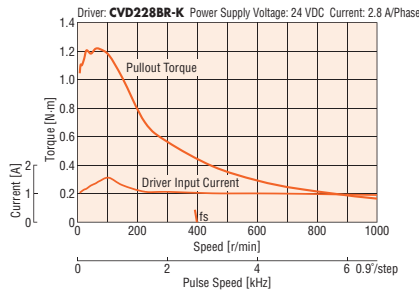

PKP268MD28A/PKP268MD28B

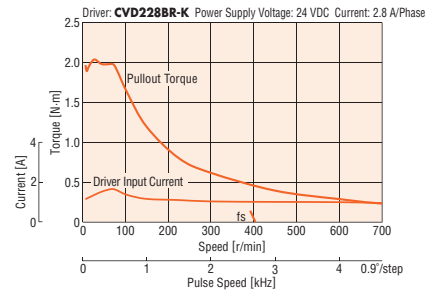

**Note**

- Data for the speed – torque characteristics is based on Oriental Motor's internal measurement conditions. If the conditions are changed, the characteristics may also change as a result.
- Depending on the driving conditions, a considerable amount of heat may be generated by the motor. Be sure to keep the motor case temperature at 100°C or less.

## Dimensions (Unit = mm)

### Motor

Product Name	L1	L2	Mass kg
PKP264MD28A	39	–	0.46
PKP264MD28B		62	
PKP266MD28A	54	–	0.73
PKP266MD28B		77	
PKP268MD28A	76	–	1.1
PKP268MD28B		99	

- Applicable Connector  
Connector housing: 51067-0600 (Molex)  
Contact: 50217-9101 (Molex)  
Crimp tool: 57189-5000 (Molex)  
57190-5000 (Molex)

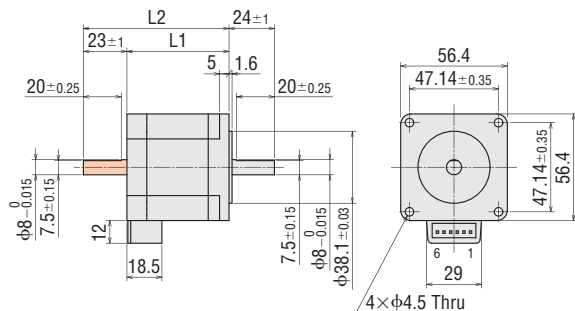

- These dimensions are for double shaft motors.  
For single shaft motors, ignore the shaded areas.

### Connection Cable (Sold separately)

#### For Motor

Product Name	Length L (m)
LC2B06C	0.6

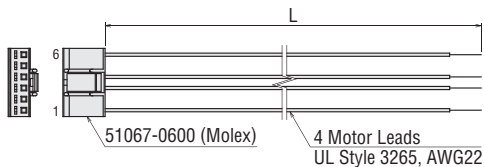

## Inner Wiring Diagram of Motor

Wiring Diagram No.: ②

- Refer to page A-431 for inner wiring diagram of motor.



# High-Resolution Type with Encoder

Frame Size 56.4 mm (Bipolar 4 lead wires)

## Specifications

Product Name	Maximum Holding Torque N·m	Rotor Inertia J: kg·m <sup>2</sup>	Rated Current A/Phase	Voltage VDC	Winding Resistance Ω/Phase	Inductance mH/Phase	Basic Step Angle	Recommended Driver Product Name*
<b>PKP264MD28A-R2FL</b>	0.6	120×10 <sup>-7</sup>	2.8	2	0.73	2.1	0.9°	<b>CVD228BR-K</b>
<b>PKP266MD28A-R2FL</b>	1.32	290×10 <sup>-7</sup>		2.8	1	3.9		
<b>PKP268MD28A-R2FL</b>	2.23	490×10 <sup>-7</sup>		3.4	1.23	5.6		

● Refer to page A-430 for encoder specifications.

\*Refer to page A-439 for details on the recommended driver.

## Speed – Torque Characteristics (Reference values)

**PKP264MD28A-R2FL**

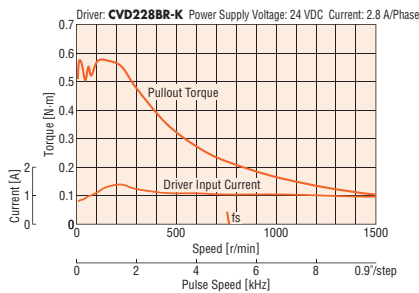

**PKP266MD28A-R2FL**

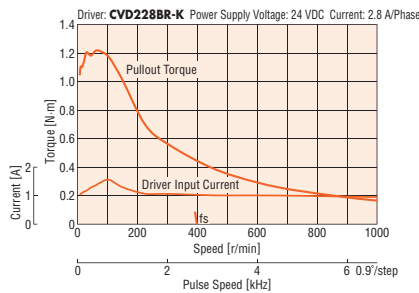

**PKP268MD28A-R2FL**

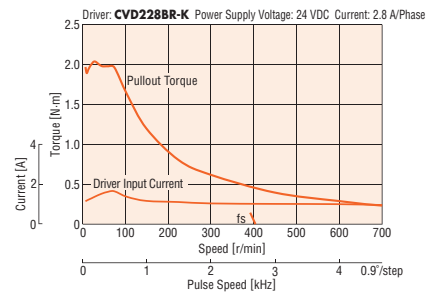

**Note**

- Data for the speed – torque characteristics is based on Oriental Motor’s internal measurement conditions. If the conditions are changed, the characteristics may also change as a result.
- Depending on the driving conditions, a considerable amount of heat may be generated by the motor. To protect the encoder, be sure to keep the motor case temperature at 85°C max.

## Dimensions (Unit = mm)

● Motor

Product Name	L	Mass kg
<b>PKP264MD28A-R2FL</b>	55.5	0.47
<b>PKP266MD28A-R2FL</b>	70.5	0.74
<b>PKP268MD28A-R2FL</b>	92.5	1.11

● Applicable Connector (Molex)

	Motor	Encoder
Connector Housing	51067-0600	51021-0800
Contact	50217-9101	50079-8100
Crimp Tool	57189-5000 57190-5000	57067-3000

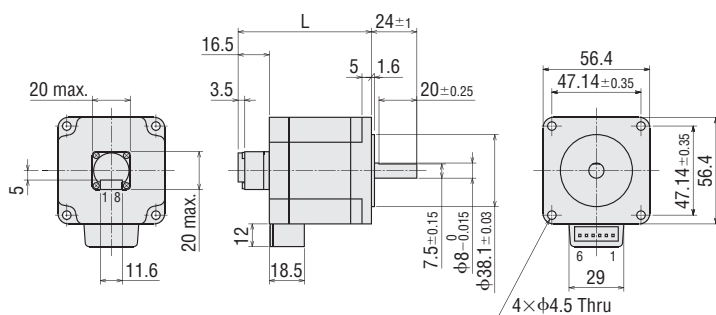

● Connection Cable (Sold separately)

◇ For Motor

Product Name	Length L (m)
<b>LC2B06C</b>	0.6

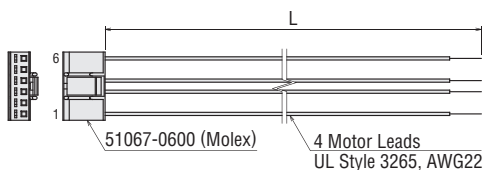

◇ For Encoder

Product Name	Length L (m)
<b>LCE08A-006</b>	0.6

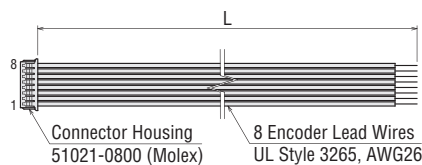

## Inner Wiring Diagram of Motor

Wiring Diagram No.: ②

● Refer to page A-431 for inner wiring diagram of motor.

## High-Resolution Type with Encoder

Frame Size 56.4 mm (Unipolar 6 lead wires)

### Specifications

Product Name	Maximum Holding Torque N·m	Rotor Inertia J: kg·m <sup>2</sup>	Rated Current A/Phase	Voltage VDC	Winding Resistance Ω/Phase	Inductance mH/Phase	Basic Step Angle	Recommended Driver Product Name*
<b>PKP264MU20A-R2FL</b>	0.51	120×10 <sup>-7</sup>	2	2.9	1.45	2.1	0.9°	<b>CMD2120P</b>
<b>PKP266MU20A-R2FL</b>	1.1	290×10 <sup>-7</sup>		4	2	3.9		
<b>PKP268MU20A-R2FL</b>	1.75	490×10 <sup>-7</sup>		4.9	2.45	5.6		

● Refer to page A-430 for encoder specifications.

\*Refer to page A-445 for details on the recommended driver.

### Speed – Torque Characteristics (Reference values)

**PKP264MU20A-R2FL**

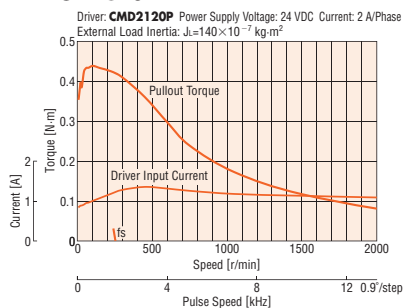

**PKP266MU20A-R2FL**

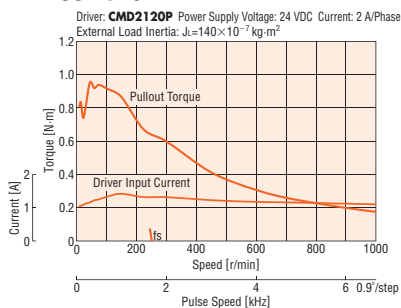

**PKP268MU20A-R2FL**

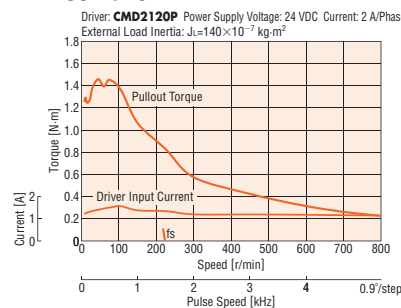

**Note**

- Data for the speed – torque characteristics is based on Oriental Motor's internal measurement conditions. If the conditions are changed, the characteristics may also change as a result.
- The data in the speed – torque characteristics represents the use of an external load inertia.
- Depending on the driving conditions, a considerable amount of heat may be generated by the motor. To protect the encoder, be sure to keep the motor case temperature at 85°C max.

### Dimensions (Unit = mm)

● Motor

Product Name	L	Mass kg
<b>PKP264MU20A-R2FL</b>	55.5	0.47
<b>PKP266MU20A-R2FL</b>	70.5	0.74
<b>PKP268MU20A-R2FL</b>	92.5	1.11

● Applicable Connector (Molex)

	Motor	Encoder
Connector Housing	51067-0600	51021-0800
Contact	50217-9101	50079-8100
Crimp Tool	57189-5000 57190-5000	57067-3000

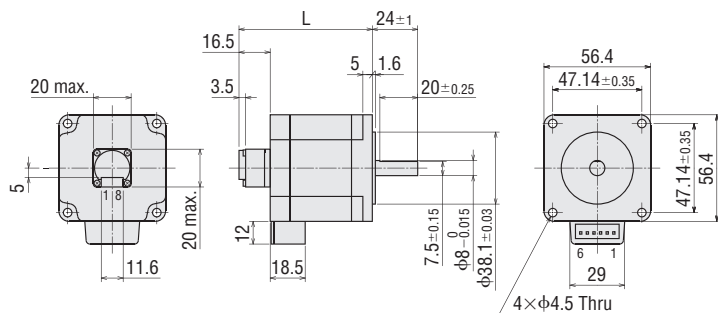

● Connection Cable (Sold separately)

◇ For Motor

Product Name	Length L (m)
<b>LC2U06C</b>	0.6
<b>LC2U10C</b>	1

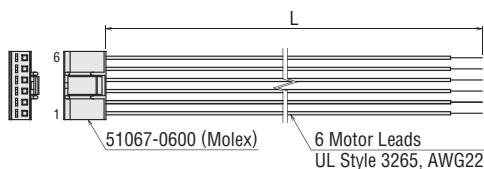

◇ For Encoder

Product Name	Length L (m)
<b>LCE08A-006</b>	0.6

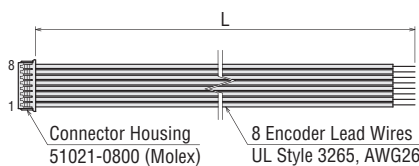

### Inner Wiring Diagram of Motor

Wiring Diagram No.: ⑥

● Refer to page A-431 for inner wiring diagram of motor.

Overview,  
Product  
Series

AC Input  
Motor &  
Driver

0.36°/Geared  
Absolute  
AZ

0.36°/Geared  
AR

0.72°/Geared  
RK II

DC Input  
Motor &  
Driver

0.36°/Geared  
Absolute  
AZ

0.36°/Geared  
AR

1.8°/0.72°  
/0.36°  
CVK

0.72°/0.36°  
/Geared  
CRK

1.8°/Geared  
RBK

Motor Only  
/Driver Only

1.8°/0.9°  
PKP/PK

Geared  
PKP/PK

0.72°/0.36°  
PKP/PK

Driver

Accessories

# High-Resolution Type with Electromagnetic Brake

Frame Size 56.4 mm (Bipolar 4 lead wires)

## Specifications

Product Name	Maximum Holding Torque N·m	Rotor Inertia J: kg·m <sup>2</sup>	Rated Current A/Phase	Voltage VDC	Winding Resistance Ω/Phase	Inductance mH/Phase	Basic Step Angle	Electromagnetic brake Static friction torque N·m
<b>PKP264MD28M</b>	0.6	270×10 <sup>-7</sup>	2.8	2	0.73	2.1	0.9°	1.5
<b>PKP266MD28M</b>	1.32	440×10 <sup>-7</sup>		2.8	1	3.9		
<b>PKP268MD28M</b>	2.23	640×10 <sup>-7</sup>		3.4	1.23	5.6		

● Refer to page A-430 for electromagnetic brake specifications.

## Speed – Torque Characteristics (Reference values)

**PKP264MD28M**

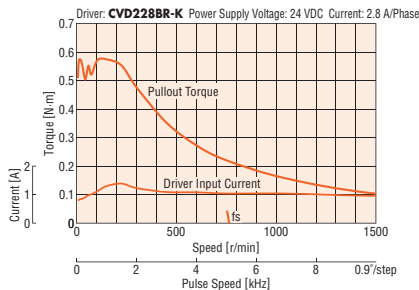

**PKP266MD28M**

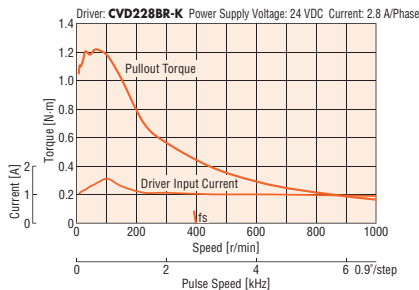

**PKP268MD28M**

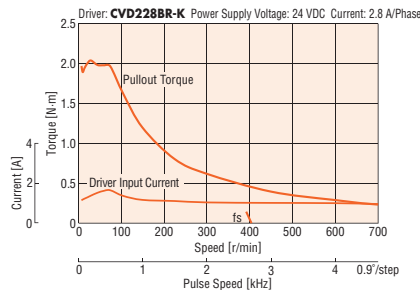

**Note**

- Data for the speed – torque characteristics is based on Oriental Motor’s internal measurement conditions. If the conditions are changed, the characteristics may also change as a result.
- Depending on the driving conditions, a considerable amount of heat may be generated by the motor. Be sure to keep the motor case temperature at 100°C or less.

## Dimensions (Unit = mm)

● Motor

Product Name	L	Mass kg
<b>PKP264MD28M</b>	75.5	0.76
<b>PKP266MD28M</b>	90.5	1.03
<b>PKP268MD28M</b>	112.5	1.4

- Applicable Connector (Molex)  
Connector housing: 51067-0600  
Contact: 50217-9101  
Crimp tool: 57189-5000  
57190-5000

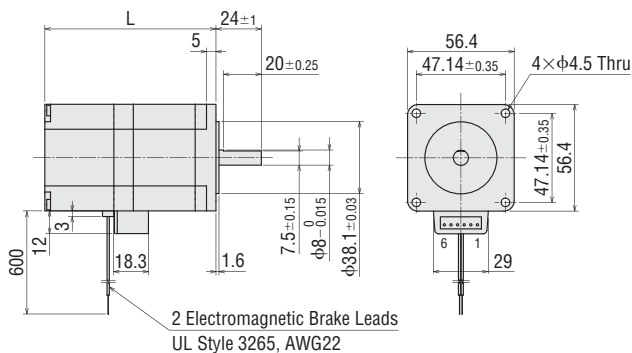

● Connection Cable (Sold separately)

◇ For Motor

Product Name	Length L (m)
<b>LC2B06C</b>	0.6

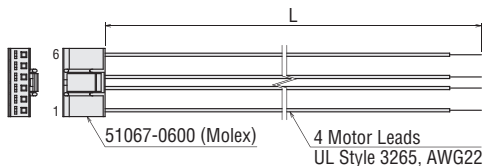

## Inner Wiring Diagram of Motor

Wiring Diagram No.: ②

- Refer to page A-431 for inner wiring diagram of motor.



## High-Resolution Type with Electromagnetic Brake

Frame Size 56.4 mm (Unipolar 6 lead wires)

### Specifications

Product Name	Maximum Holding Torque N·m	Rotor Inertia J: kg·m <sup>2</sup>	Rated Current A/Phase	Voltage VDC	Winding Resistance Ω/Phase	Inductance mH/Phase	Basic Step Angle	Electromagnetic brake Static friction torque N·m
<b>PKP264MU20M</b>	0.51	270×10 <sup>-7</sup>	2	2.9	1.45	2.1	0.9°	1.5
<b>PKP266MU20M</b>	1.1	440×10 <sup>-7</sup>		4	2	3.9		
<b>PKP268MU20M</b>	1.75	640×10 <sup>-7</sup>		4.9	2.45	5.6		

● Refer to page A-430 for electromagnetic brake specifications.

### Speed – Torque Characteristics (Reference values)

**PKP264MU20M**

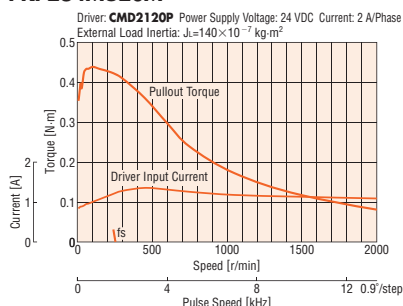

**PKP266MU20M**

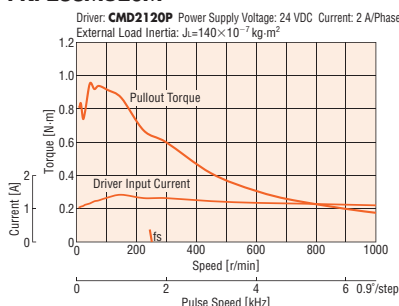

**PKP268MU20M**

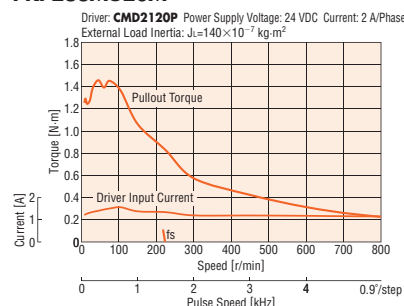

**Note**

- Data for the speed – torque characteristics is based on Oriental Motor’s internal measurement conditions. If the conditions are changed, the characteristics may also change as a result.
- The data in the speed – torque characteristics represents the use of an external load inertia.
- Depending on the driving conditions, a considerable amount of heat may be generated by the motor. Be sure to keep the motor case temperature at 100°C or less.

### Dimensions (Unit = mm)

● Motor

Product Name	L	Mass kg
<b>PKP264MU20M</b>	75.5	0.76
<b>PKP266MU20M</b>	90.5	1.03
<b>PKP268MU20M</b>	112.5	1.4

- Applicable Connector (Molex)  
Connector housing: 51067-0600  
Contact: 50217-9101  
Crimp tool: 57189-5000  
57190-5000

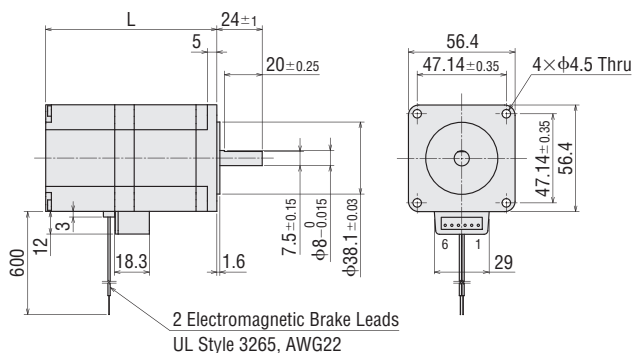

### Inner Wiring Diagram of Motor

Wiring Diagram No.: ⑥

- Refer to page A-431 for inner wiring diagram of motor.

● Connection Cable (Sold separately)

◇ For Motor

Product Name	Length L (m)
<b>LC2U06C</b>	0.6
<b>LC2U10C</b>	1

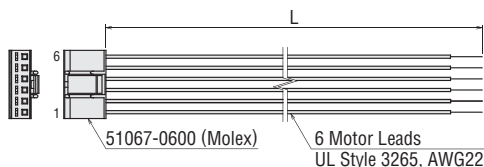

Overview,  
Product  
Series

AC Input  
Motor &  
Driver

0.36°/Geared  
**αSTEP**  
Absolute  
AZ

0.36°/Geared  
**αSTEP**  
AR

0.72°/Geared  
RKII

DC Input  
Motor &  
Driver

0.36°/Geared  
**αSTEP**  
Absolute  
AZ

0.36°/Geared  
**αSTEP**  
AR

1.8°/0.72°  
/0.36°  
CVK

0.72°/0.36°  
/Geared  
CRK

1.8°/Geared  
RBK

Motor Only  
/Driver Only

1.8°/0.9°  
PKP/PK

Geared  
PKP/PK

0.72°/0.36°  
PKP/PK

Driver

Accessories

# Flat Type Frame Size 60 mm (Bipolar 4 lead wires)

## Specifications

Product Name	Maximum Holding Torque N·m	Rotor Inertia J: kg·m <sup>2</sup>	Rated Current A/Phase	Voltage VDC	Winding Resistance Ω/Phase	Inductance mH/Phase	Basic Step Angle	Recommended Driver Product Name*
<b>PKP262FD15AW</b>	0.18	$68 \times 10^{-7}$	1.5	2.25	1.5	1.4	1.8°	<b>CVD215BR-K</b>

\*Refer to page A-439 for details on the recommended driver.

## Speed – Torque Characteristics (Reference values)

### PKP262FD15AW

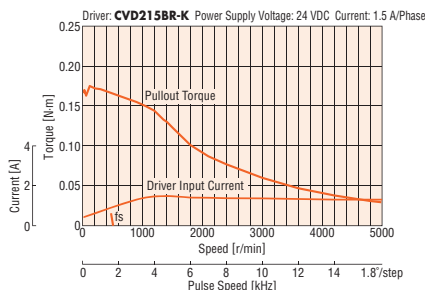

#### Note

- Data for the speed – torque characteristics is based on Oriental Motor's internal measurement conditions. If the conditions are changed, the characteristics may also change as a result.
- Depending on the driving conditions, a considerable amount of heat may be generated by the motor. Be sure to keep the motor case temperature at 100°C or less.

## Dimensions (Unit = mm)

### Motor

Product Name	Mass kg
<b>PKP262FD15AW</b>	0.2

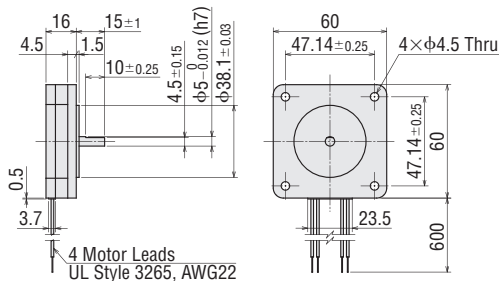

## Inner Wiring Diagram of Motor

Wiring Diagram No.: ③

- Refer to page A-431 for inner wiring diagram of motor.

## Flat Type with Harmonic Gear

Frame Size  $\phi 72$  mm (Bipolar 4 lead wires)

### Specifications

Product Name	Maximum Holding Torque N·m	Rotor Inertia J: kg·m <sup>2</sup>	Rated Current A/Phase	Voltage VDC	Winding Resistance $\Omega$ /Phase	Inductance mH/Phase	Basic Step Angle	Gear Ratio	Permissible Torque N·m	Maximum Instantaneous Torque N·m	Lost Motion (Load Torque) arcmin	Speed Range r/min	Recommended Driver Product Name*
<b>PKP262FD15AW-H50</b>	3.7	90×10 <sup>-7</sup>	1.5	1.65	1.1	0.8	0.036°	50	3.7	4.8	1.5 max. (±0.18 N·m)	0~70	<b>CVD215BR-K</b>
<b>PKP262FD15AW-H100</b>	5.4						0.018°	100	5.4	7.7	1.5 max. (±0.27 N·m)	0~35	

\*Refer to page A-439 for details on the recommended driver.

**Note**

- The rotor inertia represents a sum of the inertia of the harmonic gear converted to motor shaft values.

### Speed – Torque Characteristics (Reference values)

**PKP262FD15AW-H50**

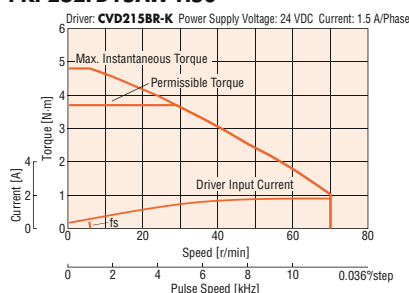

**PKP262FD15AW-H100**

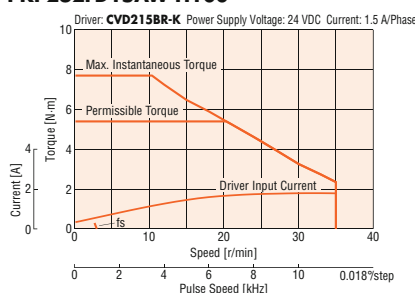

**Note**

- Data for the speed – torque characteristics is based on Oriental Motor's internal measurement conditions. If the conditions are changed, the characteristics may also change as a result.
- Depending on the driving conditions, a considerable amount of heat may be generated by the motor. Be sure to keep the motor case temperature at 100°C or less.

### Dimensions (Unit = mm)

● Motor

Product Name	Mass kg
<b>PKP262FD15AW-H50</b>	0.6
<b>PKP262FD15AW-H100</b>	

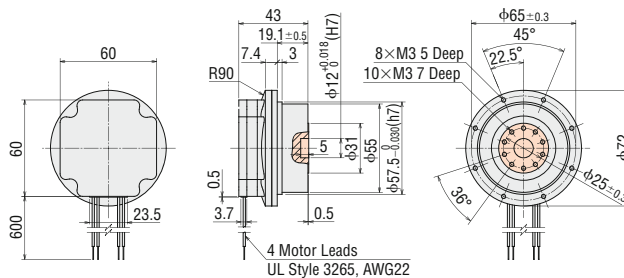

● shaded areas are rotating parts.

### Inner Wiring Diagram of Motor

Wiring Diagram No.: ③

- Refer to page A-431 for inner wiring diagram of motor.

Overview, Product Series

AC Input Motor & Driver

0.36°/Geared  $\alpha$ STEP Absolute AZ

0.36°/Geared  $\alpha$ STEP AR

0.72°/Geared RKII

DC Input Motor & Driver

0.36°/Geared  $\alpha$ STEP Absolute AZ

0.36°/Geared  $\alpha$ STEP AR

1.8°/0.72°/0.36° CVK

0.72°/0.36°/Geared CRK

1.8°/Geared RBK

Motor Only /Driver Only

1.8°/0.9° PKP/PK

Geared PKP/PK

0.72°/0.36° PKP/PK

Driver

Accessories

# SH Geared Type Frame Size 28 mm (Bipolar 4 lead wires)

## Specifications

Product Name	Maximum Holding Torque N·m	Rotor Inertia J: kg·m <sup>2</sup>	Rated Current A/Phase	Voltage VDC	Winding Resistance Ω/Phase	Inductance mH/Phase	Basic Step Angle	Gear Ratio	Permissible Torque N·m	Speed Range r/min	Backlash arcmin	Recommended Driver Product Name*
PKP223D15□-SG7.2	0.3	9×10 <sup>-7</sup>	1.5	1.8	1.2	0.74	0.25°	7.2	0.3	0~416	90 (1.5)	CVD215BR-K
PKP223D15□-SG9							0.2°	9		0~333		
PKP223D15□-SG10	0.4	9×10 <sup>-7</sup>	1.5	1.8	1.2	0.74	0.18°	10	0.4	0~300	90 (1.5)	CVD215BR-K
PKP223D15□-SG18							0.1°	18		0~166		
PKP223D15□-SG36							0.05°	36		0~83		

● Either **A** (single shaft) or **B** (double shaft) indicating the configuration is specified where the box □ is located in the product name.

\*Refer to page A-430 for details on the recommended driver.

## Speed – Torque Characteristics (Reference values)

PKP223D15A-SG7.2/PKP223D15B-SG7.2

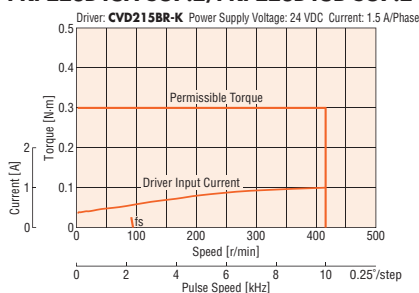

PKP223D15A-SG9/PKP223D15B-SG9

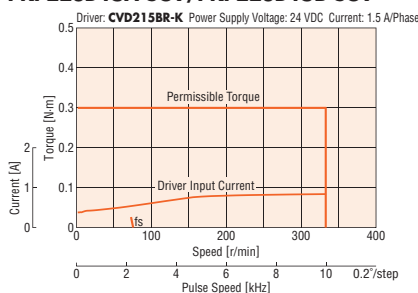

PKP223D15A-SG10/PKP223D15B-SG10

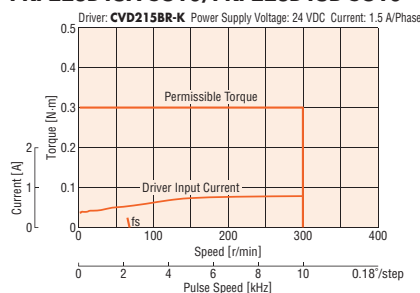

PKP223D15A-SG18/PKP223D15B-SG18

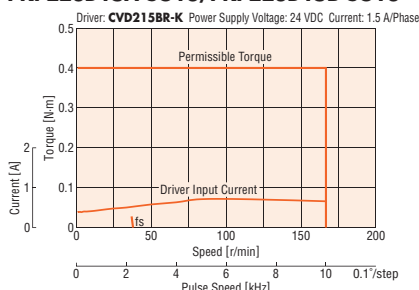

PKP223D15A-SG36/PKP223D15B-SG36

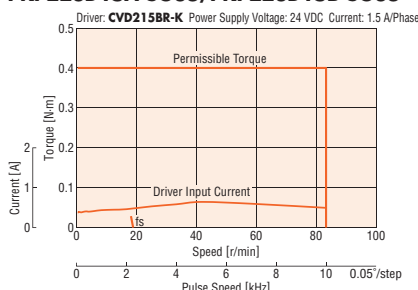

### Note

- Data for the speed – torque characteristics is based on Oriental Motor's internal measurement conditions. If the conditions are changed, the characteristics may also change as a result.
- Depending on the driving conditions, a considerable amount of heat may be generated by the motor. Be sure to keep the motor case temperature at 100°C or less.

## Dimensions (Unit = mm)

### Motor

Product Name	Gear Ratio	Mass kg
PKP223D15A-SG□	7.2, 9, 10, 18, 36	0.16
PKP223D15B-SG□		

- A number indicating the gear ratio is specified in the box □ in the product name.
- Applicable Connector  
Connector housing: 51065-0600 (Molex)  
Contact: 50212-8100 (Molex)  
Crimp tool: 57176-5000 (Molex)

### Connection Cable (Sold separately)

#### ◇ For Motor

Product Name	Length L (m)
LC2B06A	0.6

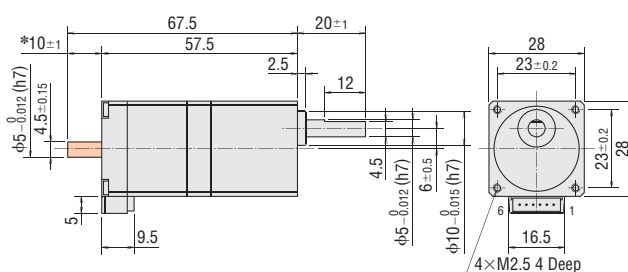
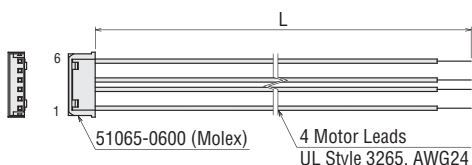

\*The length of the shaft flat on the double shaft model is 10±0.25.

- These dimensions are for double shaft motors.  
For single shaft motors, ignore the shaded areas.

## Inner Wiring Diagram of Motor

Wiring Diagram No.: ②

- Refer to page A-431 for inner wiring diagram of motor.

## SH Geared Type Frame Size 28 mm (Unipolar 6 lead wires)

### Specifications

Product Name	Maximum Holding Torque N-m	Rotor Inertia J: kg·m <sup>2</sup>	Rated Current A/Phase	Voltage VDC	Winding Resistance Ω/Phase	Inductance mH/Phase	Basic Step Angle	Gear Ratio	Permissible Torque N-m	Speed Range r/min	Backlash arcmin	Recommended Driver Product Name*
PKP223U09□-SG7.2	0.3	9×10 <sup>-7</sup>	0.95	2.66	2.8	1	0.25°	7.2	0.3	0~416	90 (1.5°)	CMD2109P
PKP223U09□-SG9							0.2°	9		0~333		
PKP223U09□-SG10	0.4	9×10 <sup>-7</sup>	0.95	2.66	2.8	1	0.18°	10	0.4	0~300	90 (1.5°)	CMD2109P
PKP223U09□-SG18							0.1°	18		0~166		
PKP223U09□-SG36							0.05°	36		0~83		

● Either **A** (single shaft) or **B** (double shaft) indicating the configuration is specified where the box □ is located in the product name.  
\*Refer to page A-445 for details on the recommended driver.

### Speed – Torque Characteristics (Reference values)

PKP223U09A-SG7.2/PKP223U09B-SG7.2

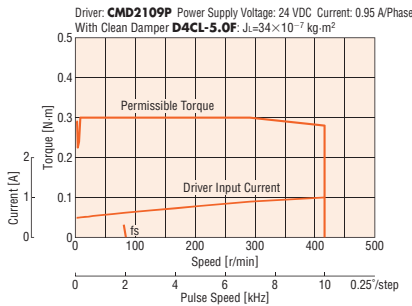

PKP223U09A-SG9/PKP223U09B-SG9

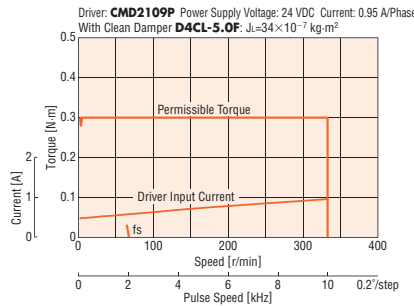

PKP223U09A-SG10/PKP223U09B-SG10

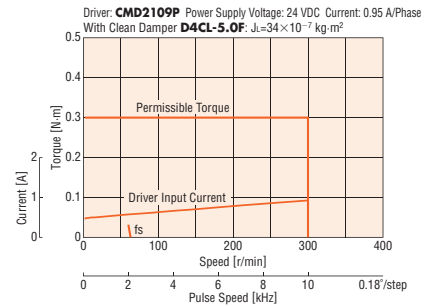

PKP223U09A-SG18/PKP223U09B-SG18

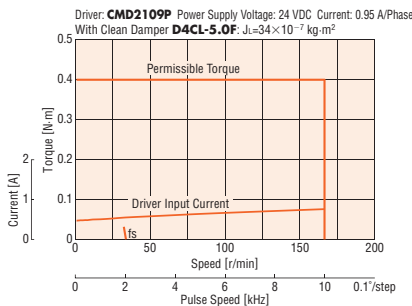

PKP223U09A-SG36/PKP223U09B-SG36

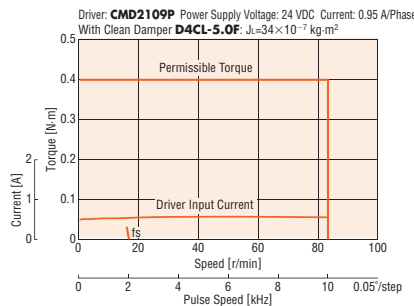

#### Note

- Data for the speed – torque characteristics is based on Oriental Motor's internal measurement conditions. If the conditions are changed, the characteristics may also change as a result.
- If there is a "clean damper" entry in the speed – torque characteristics, the data is for a double shaft motor when a clean damper is equipped.
- Depending on the driving conditions, a considerable amount of heat may be generated by the motor. Be sure to keep the motor case temperature at 100°C or less.

### Dimensions (Unit = mm)

#### Motor

Product Name	Gear Ratio	Mass kg
PKP223U09A-SG□	7.2, 9, 10, 18, 36	0.16
PKP223U09B-SG□		

- A number indicating the gear ratio is specified in the box □ in the product name.
- Applicable Connector  
Connector housing: 51065-0600 (Molex)  
Contact: 50212-8100 (Molex)  
Crimp tool: 57176-5000 (Molex)

#### Connection Cable (Sold separately)

##### ◇ For Motor

Product Name	Length L (m)
LC2U06A	0.6
LC2U10A	1

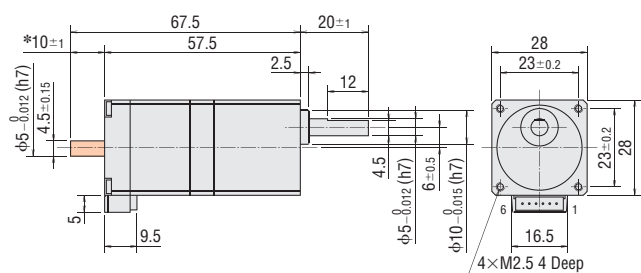
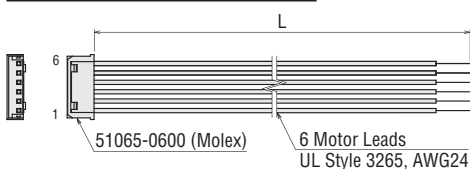

- \*The length of the shaft flat on the double shaft model is 10±0.25.
- These dimensions are for double shaft motors.  
For single shaft motors, ignore the shaded areas.

### Inner Wiring Diagram of Motor

Wiring Diagram No.: ⑥

- Refer to page A-431 for inner wiring diagram of motor.

Overview,  
Product  
Series

AC Input  
Motor &  
Driver

0.36°/Geared  
αSTEP  
Absolute  
AZ

0.36°/Geared  
αSTEP  
AR

0.72°/Geared  
RKII

DC Input  
Motor &  
Driver

0.36°/Geared  
αSTEP  
Absolute  
AZ

0.36°/Geared  
αSTEP  
AR

1.8°/0.72°  
/0.36°  
CVK

0.72°/0.36°  
/Geared  
CRK

1.8°/Geared  
RBK

Motor Only  
/Driver Only

1.8°/0.9°  
PKP/PK

Geared  
PKP/PK

0.72°/0.36°  
PKP/PK

Driver

Accessories

# SH Geared Type Frame Size 42 mm (Bipolar 4 lead wires)

## Specifications

Product Name	Maximum Holding Torque N·m	Rotor Inertia J: kg·m <sup>2</sup>	Rated Current A/ phase	Voltage VDC	Winding Resistance Ω/Phase	Inductance mH/Phase	Basic Step Angle	Gear Ratio	Permissible Torque N·m	Speed Range r/min	Backlash arcmin	Recommended Driver Product Name*
PKP243D15□2-SG3.6	0.2	36 × 10 <sup>-7</sup>	1.5	0.83	0.55	0.77	0.5°	3.6	0.2	0~833	90 (1.5°)	CVD223FBR-K
PKP243D23□2-SG3.6			2.3	0.87	0.38	0.41						
PKP243D15□2-SG7.2	0.4		1.5	0.83	0.55	0.77	0.25°	7.2	0.4	0~416		
PKP243D23□2-SG7.2			2.3	0.87	0.38	0.41						
PKP243D15□2-SG9	0.5		1.5	0.83	0.55	0.77	0.2°	9	0.5	0~333		
PKP243D23□2-SG9			2.3	0.87	0.38	0.41						
PKP243D15□2-SG10	0.56		1.5	0.83	0.55	0.77	0.18°	10	0.56	0~300		
PKP243D23□2-SG10			2.3	0.87	0.38	0.41						
PKP243D15□2-SG18	0.8		1.5	0.83	0.55	0.77	0.1°	18	0.8	0~166		
PKP243D23□2-SG18			2.3	0.87	0.38	0.41						
PKP243D15□2-SG36	0.8	1.5	0.83	0.55	0.77	0.05°	36	0.8	0~83			
PKP243D23□2-SG36		2.3	0.87	0.38	0.41							

● Either **A** (single shaft) or **B** (double shaft) indicating the configuration is specified where the box □ is located in the product name.  
\*Refer to page A-439 for details on the recommended driver.

## Speed – Torque Characteristics (Reference values)

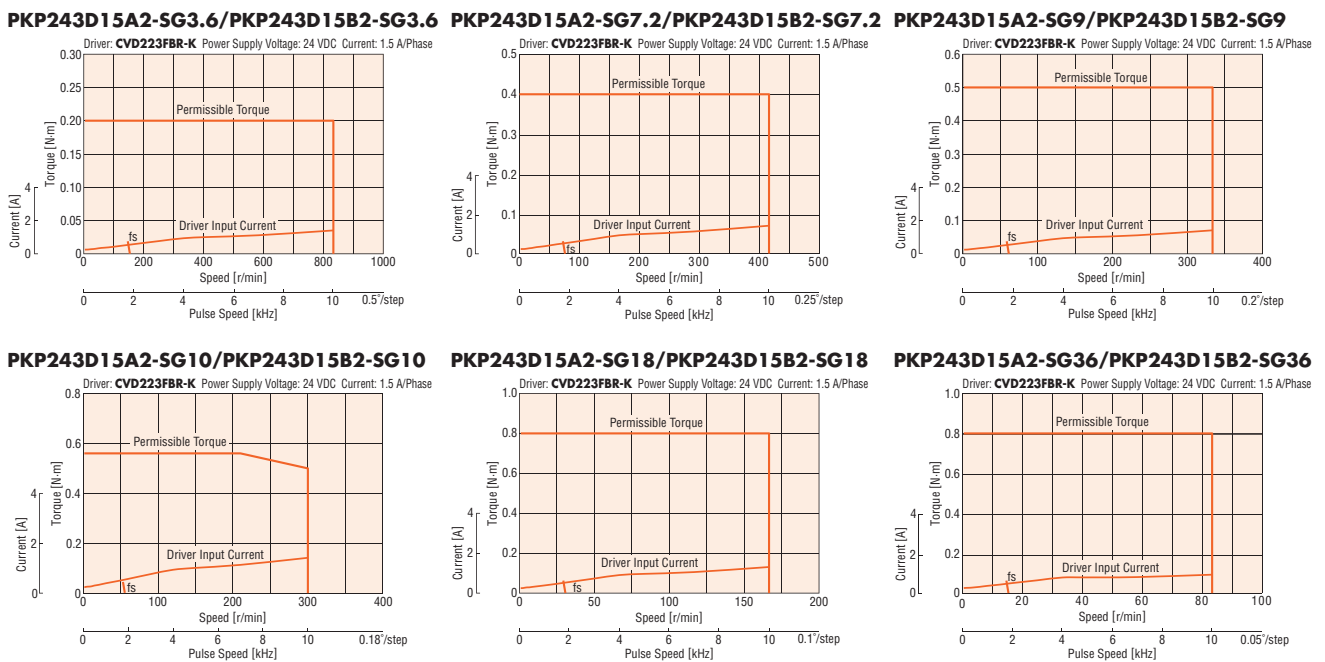

### Note

- Data for the speed – torque characteristics is based on Oriental Motor's internal measurement conditions. If the conditions are changed, the characteristics may also change as a result.
- Depending on the driving conditions, a considerable amount of heat may be generated by the motor. Be sure to keep the motor case temperature at 100°C or less.



# SH Geared Type Frame Size 42 mm (Unipolar 5 lead wires)

## Specifications

Product Name	Maximum Holding Torque N·m	Rotor Inertia J: kg·m <sup>2</sup>	Rated Current A/Phase	Voltage VDC	Winding Resistance Ω/Phase	Inductance mH/Phase	Basic Step Angle	Gear Ratio	Permissible Torque N·m	Speed Range r/min	Backlash arcmin	Recommended Driver Product Name*
PKP243U09□2-SG3.6	0.2	36×10 <sup>-7</sup>	0.95	2	2.1	1.8	0.5°	3.6	0.2	0~833	90 (1.5)	<b>CMD2109P</b>
PKP243U09□2-SG7.2	0.4						0.25°	7.2	0.4	0~416		
PKP243U09□2-SG9	0.5						0.2°	9	0.5	0~333		
PKP243U09□2-SG10	0.56						0.18°	10	0.56	0~300		
PKP243U09□2-SG18	0.8						0.1°	18	0.8	0~166		
PKP243U09□2-SG36	0.8						0.05°	36	0.8	0~83		

● Either **A** (single shaft) or **B** (double shaft) indicating the configuration is specified where the box □ is located in the product name.  
\*Refer to page A-445 for details on the recommended driver.

## Speed – Torque Characteristics (Reference values)

**PKP243U09A2-SG3.6/PKP243U09B2-SG3.6**   **PKP243U09A2-SG7.2/PKP243U09B2-SG7.2**   **PKP243U09A2-SG9/PKP243U09B2-SG9**

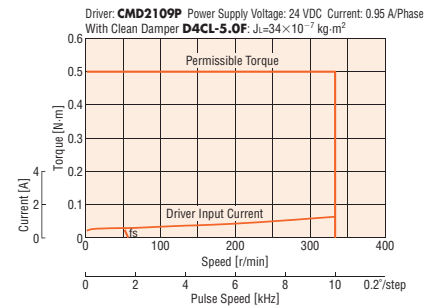
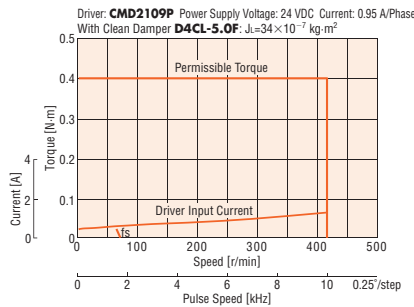
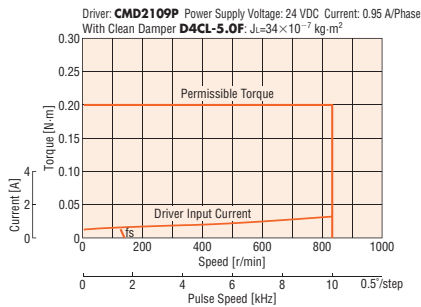

**PKP243U09A2-SG10/PKP243U09B2-SG10**   **PKP243U09A2-SG18/PKP243U09B2-SG18**   **PKP243U09A2-SG36/PKP243U09B2-SG36**

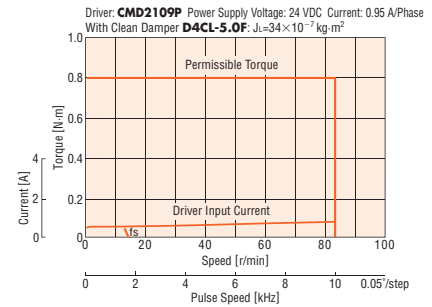
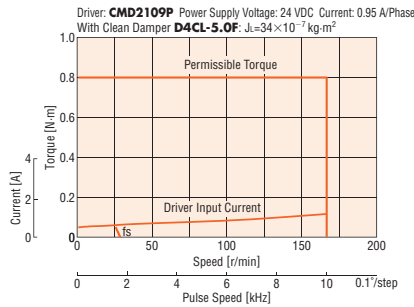
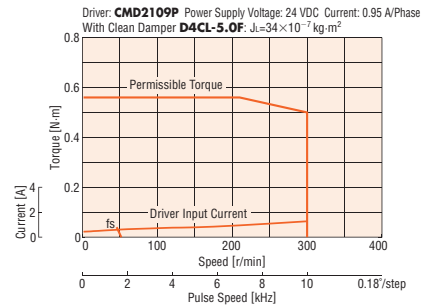

### Note

- Data for the speed – torque characteristics is based on Oriental Motor's internal measurement conditions. If the conditions are changed, the characteristics may also change as a result.
- If there is a "clean damper" entry in the speed – torque characteristics, the data is for a double shaft motor when a clean damper is equipped.
- Depending on the driving conditions, a considerable amount of heat may be generated by the motor. Be sure to keep the motor case temperature at 100°C or less.



## Dimensions (Unit = mm)

### Motor

Product Name	Gear Ratio	Mass kg
<b>PKP243U09A2-SG</b> □	<b>3.6, 7.2, 9, 10, 18, 36</b>	0.33
<b>PKP243U09B2-SG</b> □		

● A number indicating the gear ratio is specified in the box □ in the product name.

#### ● Applicable Connector

Connector Housing: MDF97-5S-3.5C (HIROSE ELECTRIC CO., LTD.)

Contact: MDF97-22SC (HIROSE ELECTRIC CO., LTD.)

Crimp Tool: HT801/MDF97-22S (HIROSE ELECTRIC CO., LTD.)

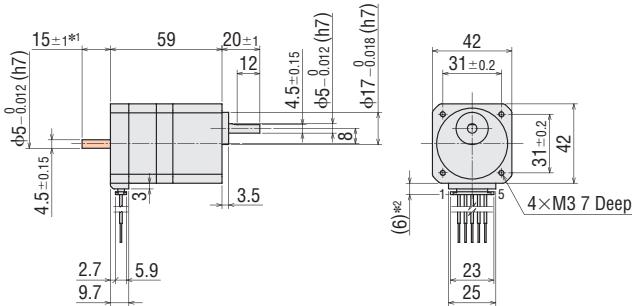

\*1 The length of the shaft flat on the double shaft model is 15±0.25.

\*2 With connection cable

● These dimensions are for double shaft motors. For single shaft motors, ignore the shaded areas.

### ● Connection Cable (Sold separately)

#### ◇ For Motor

Product Name	Length L (m)
<b>LC2U06E</b>	0.6

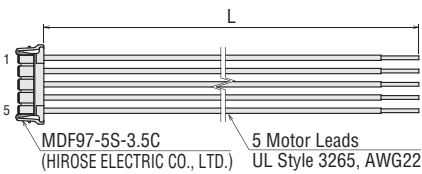

## Inner Wiring Diagram of Motor

Wiring Diagram No.: ④

● Refer to page A-431 for inner wiring diagram of motor.

Overview, Product Series

AC Input Motor & Driver

0.36°/Geared  
**αSTEP Absolute AZ**

0.36°/Geared  
**αSTEP AR**

0.72°/Geared  
**RK II**

DC Input Motor & Driver

0.36°/Geared  
**αSTEP Absolute AZ**

0.36°/Geared  
**αSTEP AR**

1.8°/0.72°/0.36°  
**CVK**

0.72°/0.36°/Geared  
**CRK**

1.8°/Geared  
**RBK**

Motor Only / Driver Only

1.8°/0.9°  
**PKP/PK**

Geared  
**PKP/PK**

0.72°/0.36°  
**PKP/PK**

Driver

Accessories

# SH Geared Type Frame Size 60 mm (Bipolar 4 lead wires)

## Specifications

Product Name	Maximum Holding Torque N·m	Rotor Inertia J: kg·m <sup>2</sup>	Rated Current A/Phase	Voltage VDC	Winding Resistance Ω/Phase	Inductance mH/Phase	Basic Step Angle	Gear Ratio	Permissible Torque N·m	Speed Range r/min	Backlash arcmin	Recommended Driver Product Name*
PKP264D14□2-SG3.6	1	140×10 <sup>-7</sup>	1.4	2	1.4	3.1	0.5°	3.6	1	0~833	70 (1.17°)	CVD228BR-K
PKP264D28□2-SG3.6			2.8	0.92	0.33	0.81						
PKP264D14□2-SG7.2	2		1.4	2	1.4	3.1	0.25°	7.2	2	0~416		
PKP264D28□2-SG7.2			2.8	0.92	0.33	0.81						
PKP264D14□2-SG9	2.5		1.4	2	1.4	3.1	0.2°	9	2.5	0~333		
PKP264D28□2-SG9			2.8	0.92	0.33	0.81						
PKP264D14□2-SG10	2.7		1.4	2	1.4	3.1	0.18°	10	2.7	0~300		
PKP264D28□2-SG10			2.8	0.92	0.33	0.81						
PKP264D14□2-SG18	3		1.4	2	1.4	3.1	0.1°	18	3	0~166		
PKP264D28□2-SG18			2.8	0.92	0.33	0.81						
PKP264D14□2-SG36	4	1.4	2	1.4	3.1	0.05°	36	4	0~83			
PKP264D28□2-SG36		2.8	0.92	0.33	0.81							

● Either **A** (single shaft) or **B** (double shaft) indicating the configuration is specified where the box □ is located in the product name.  
\*Refer to page A-439 for details on the recommended driver.

## Speed – Torque Characteristics (Reference values)

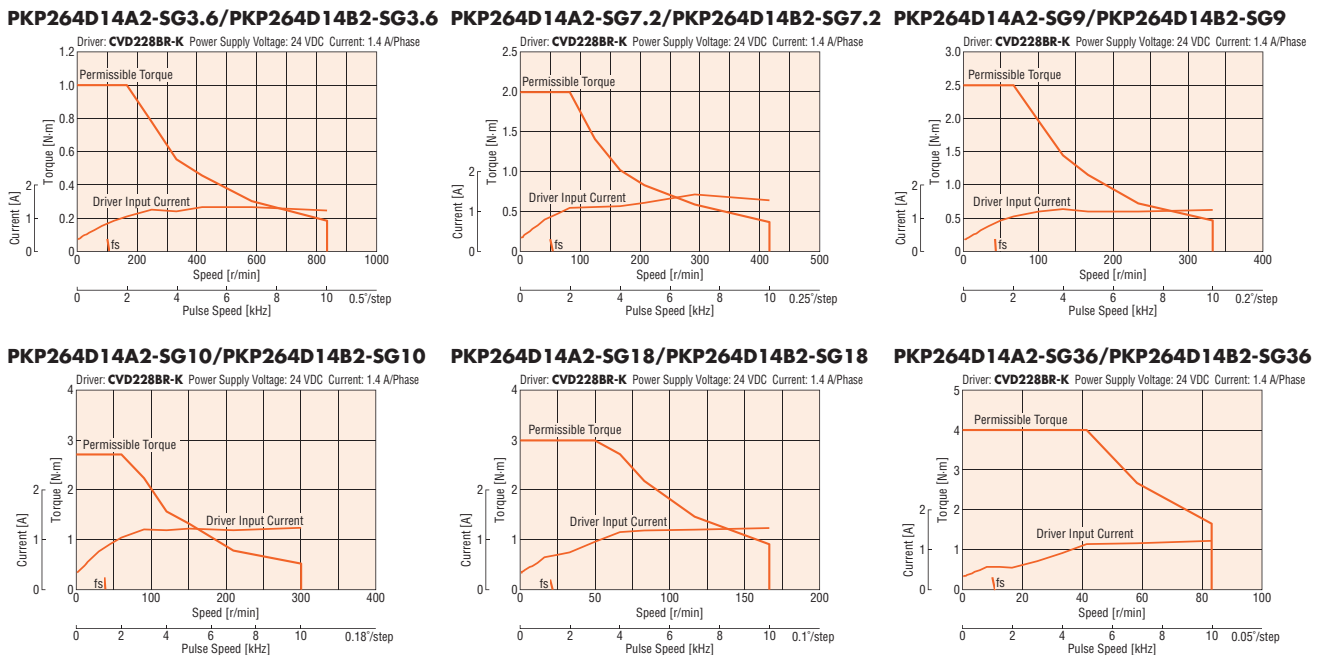

**Note**

- Data for the speed – torque characteristics is based on Oriental Motor's internal measurement conditions. If the conditions are changed, the characteristics may also change as a result.
- Depending on the driving conditions, a considerable amount of heat may be generated by the motor. Be sure to keep the motor case temperature at 100°C or less.

## Speed – Torque Characteristics (Reference values)

PKP264D28A2-SG3.6/PKP264D28B2-SG3.6 PKP264D28A2-SG7.2/PKP264D28B2-SG7.2 PKP264D28A2-SG9/PKP264D28B2-SG9

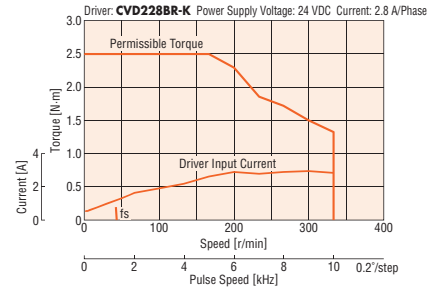
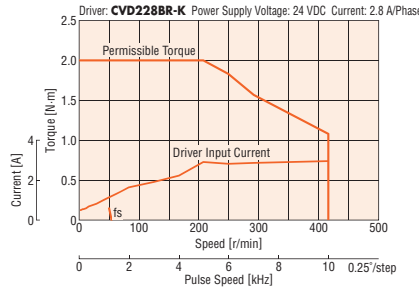
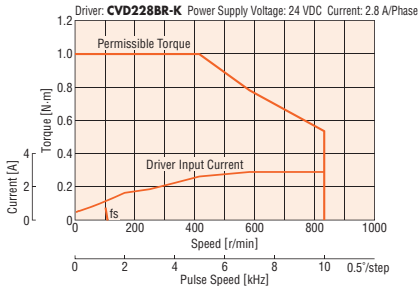

PKP264D28A2-SG10/PKP264D28B2-SG10

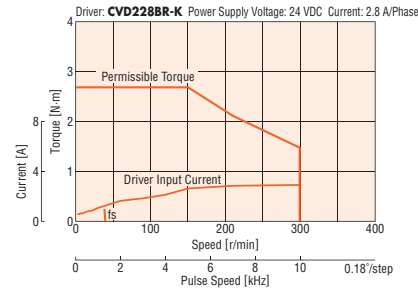

PKP264D28A2-SG18/PKP264D28B2-SG18

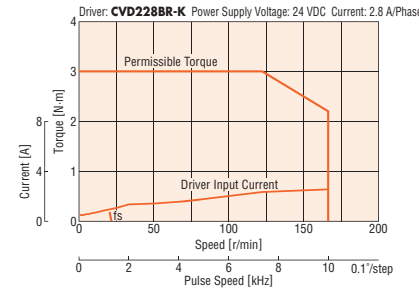

PKP264D28A2-SG36/PKP264D28B2-SG36

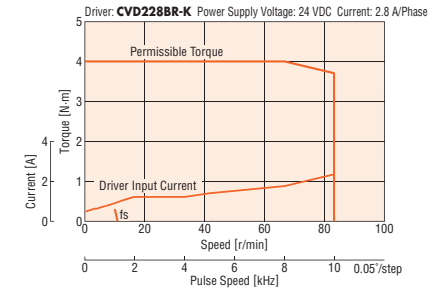

### Note

- Data for the speed – torque characteristics is based on Oriental Motor's internal measurement conditions. If the conditions are changed, the characteristics may also change as a result.
- Depending on the driving conditions, a considerable amount of heat may be generated by the motor. Be sure to keep the motor case temperature at 100°C or less.

## Dimensions (Unit = mm)

### Motor

Product Name	Gear Ratio	Mass kg
PKP264D14A2-SG□	3.6, 7.2, 9, 10, 18, 36	0.76
PKP264D14B2-SG□		
PKP264D28A2-SG□		
PKP264D28B2-SG□		

● A number indicating the gear ratio is specified in the box □ in the product name.

### Applicable Connector

Connector Housing: MDF97-5S-3.5C (HIROSE ELECTRIC CO., LTD.)  
 Contact: MDF97-22SC (HIROSE ELECTRIC CO., LTD.)  
 Crimp Tool: HT801/MDF97-22S (HIROSE ELECTRIC CO., LTD.)

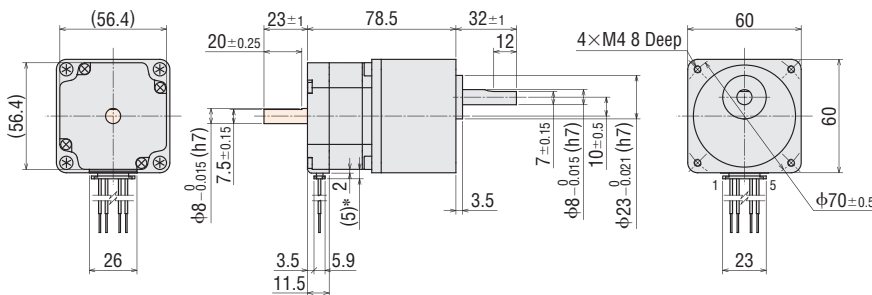

\*With connection cable

● These dimensions are for double shaft motors.

For single shaft motors, ignore the shaded areas.

### Connection Cable (Sold separately)

#### ◇ For Motor

Product Name	Length L (m)
LC2B06E	0.6

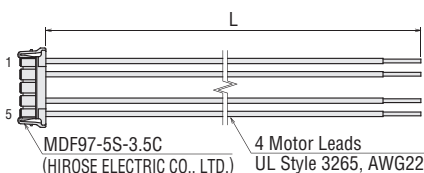

## Inner Wiring Diagram of Motor

Wiring Diagram No.: ①

● Refer to page A-431 for inner wiring diagram of motor.

Overview,  
Product  
Series

AC Input  
Motor &  
Driver

0.36°/Geared  
αSTEP  
Absolute  
AZ

0.36°/Geared  
αSTEP  
AR

0.72°/Geared  
RKII

DC Input  
Motor &  
Driver

0.36°/Geared  
αSTEP  
Absolute  
AZ

0.36°/Geared  
αSTEP  
AR

1.8°/0.72°  
/0.36°  
CVK

0.72°/0.36°  
/Geared  
CRK

1.8°/Geared  
RBK

Motor Only  
/Driver Only

1.8°/0.9°  
PKP/PK

Geared  
PKP/PK

0.72°/0.36°  
PKP/PK

Driver

Accessories

# SH Geared Type Frame Size 60 mm (Unipolar 5 lead wires)

## Specifications

Product Name	Maximum Holding Torque N·m	Rotor Inertia J: kg·m <sup>2</sup>	Rated Current A/Phase	Voltage VDC	Winding Resistance Ω/Phase	Inductance mH/Phase	Basic Step Angle	Gear Ratio	Permissible Torque N·m	Speed Range r/min	Backlash arcmin	Recommended Driver Product Name*
PKP264U10□2-SG3.6	1	140×10 <sup>-7</sup>	1	2.9	2.9	4.2	0.5°	3.6	1	0~833	70 (1.17°)	CMD2120P
PKP264U20□2-SG3.6			2	1.5	0.76	1						
PKP264U10□2-SG7.2	2		1	2.9	2.9	4.2	0.25°	7.2	2	0~416		
PKP264U20□2-SG7.2			2	1.5	0.76	1						
PKP264U10□2-SG9	2.5		1	2.9	2.9	4.2	0.2°	9	2.5	0~333		
PKP264U20□2-SG9			2	1.5	0.76	1						
PKP264U10□2-SG10	2.7		1	2.9	2.9	4.2	0.18°	10	2.7	0~300		
PKP264U20□2-SG10			2	1.5	0.76	1						
PKP264U10□2-SG18	3		1	2.9	2.9	4.2	0.1°	18	3	0~166		
PKP264U20□2-SG18			2	1.5	0.76	1						
PKP264U10□2-SG36	4	1	2.9	2.9	4.2	0.05°	36	4	0~83			
PKP264U20□2-SG36		2	1.5	0.76	1							

● Either **A** (single shaft) or **B** (double shaft) indicating the configuration is specified where the box □ is located in the product name.  
\*Refer to page A-445 for details on the recommended driver.

## Speed – Torque Characteristics (Reference values)

PKP264U10A2-SG3.6/PKP264U10B2-SG3.6 PKP264U10A2-SG7.2/PKP264U10B2-SG7.2 PKP264U10A2-SG9/PKP264U10B2-SG9

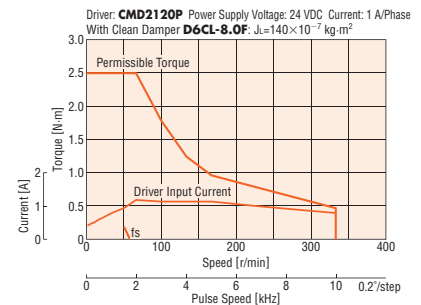
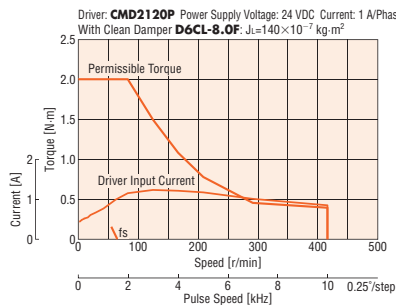
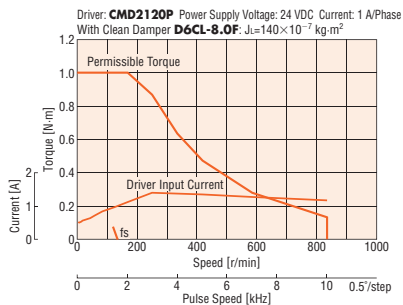

PKP264U10A2-SG10/PKP264U10B2-SG10

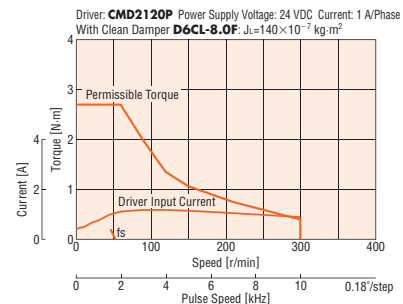

PKP264U10A2-SG18/PKP264U10B2-SG18

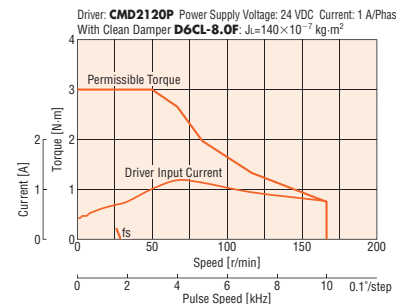

PKP264U10A2-SG36/PKP264U10B2-SG36

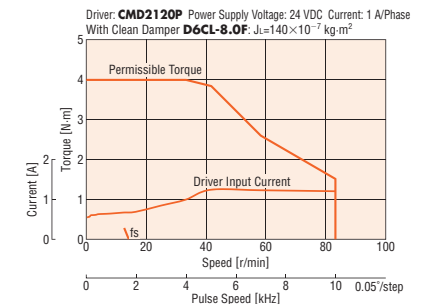

### Note

- Data for the speed – torque characteristics is based on Oriental Motor's internal measurement conditions. If the conditions are changed, the characteristics may also change as a result.
- If there is a "clean damper" entry in the speed – torque characteristics, the data is for a double shaft motor when a clean damper is equipped.
- Depending on the driving conditions, a considerable amount of heat may be generated by the motor. Be sure to keep the motor case temperature at 100°C or less.

## Speed – Torque Characteristics (Reference values)

PKP264U20A2-SG3.6/PKP264U20B2-SG3.6 PKP264U20A2-SG7.2/PKP264U20B2-SG7.2 PKP264U20A2-SG9/PKP264U20B2-SG9

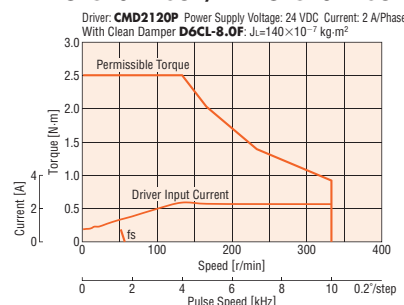
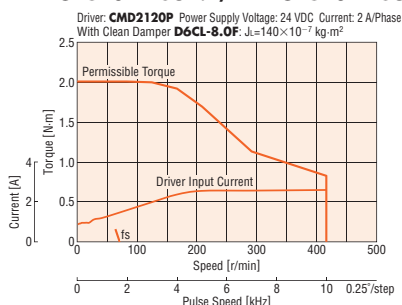
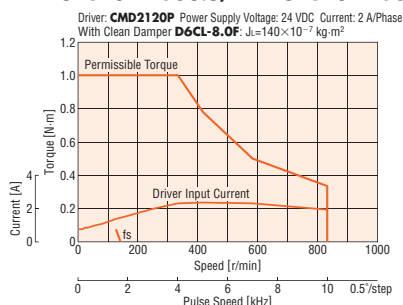

PKP264U20A2-SG10/PKP264U20B2-SG10

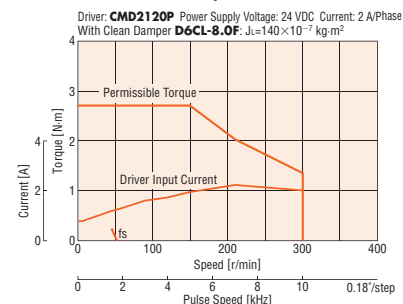

PKP264U20A2-SG18/PKP264U20B2-SG18

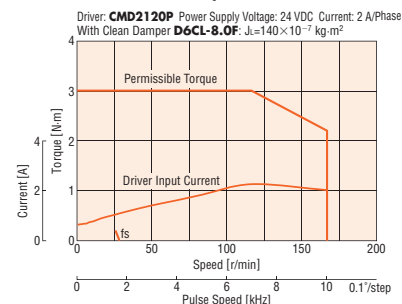

PKP264U20A2-SG36/PKP264U20B2-SG36

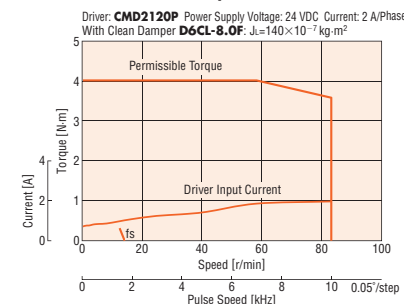

### Note

- Data for the speed – torque characteristics is based on Oriental Motor's internal measurement conditions. If the conditions are changed, the characteristics may also change as a result.
- If there is a "clean damper" entry in the speed – torque characteristics, the data is for a double shaft motor when a clean damper is equipped.
- Depending on the driving conditions, a considerable amount of heat may be generated by the motor. Be sure to keep the motor case temperature at 100°C or less.

## Dimensions (Unit = mm)

### Motor

Product Name	Gear Ratio	Mass kg
PKP264U10A2-SG□	3.6, 7.2, 9, 10, 18, 36	0.76
PKP264U10B2-SG□		
PKP264U20A2-SG□		
PKP264U20B2-SG□		

- A number indicating the gear ratio is specified in the box □ in the product name.

### Applicable Connector

Connector Housing: MDF97-5S-3.5C (HIROSE ELECTRIC CO., LTD.)

Contact: MDF97-22SC (HIROSE ELECTRIC CO., LTD.)

Crimp Tool: HT801/MDF97-22S (HIROSE ELECTRIC CO., LTD.)

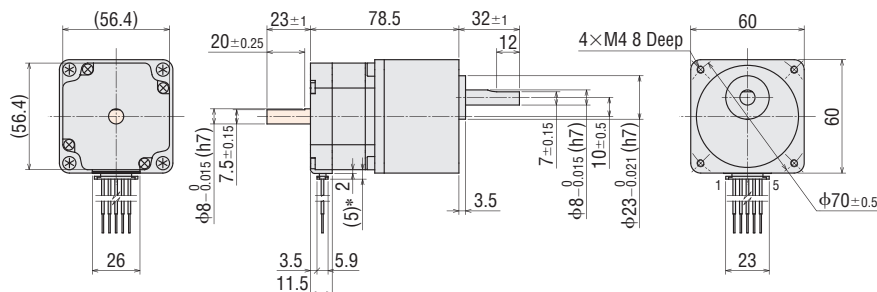

\*With connection cable

- These dimensions are for double shaft motors.

For single shaft motors, ignore the shaded areas.

### Connection Cable (Sold separately)

#### For Motor

Product Name	Length L (m)
LC2U06E	0.6

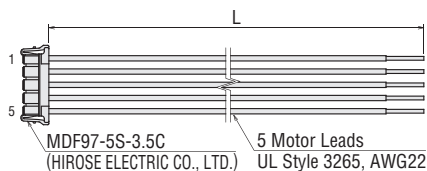

## Inner Wiring Diagram of Motor

Wiring Diagram No.: ④

- Refer to page A-431 for inner wiring diagram of motor.

Overview, Product Series

AC Input Motor & Driver

0.36°/Geared  
αSTEP Absolute AZ

0.36°/Geared  
αSTEP AR

0.72°/Geared  
RKII

DC Input Motor & Driver

0.36°/Geared  
αSTEP Absolute AZ

0.36°/Geared  
αSTEP AR

1.8°/0.72°/0.36°  
CVK

0.72°/0.36°/Geared  
CRK

1.8°/Geared  
RBK

Motor Only /Driver Only

1.8°/0.9°  
PKP/PK

Geared  
PKP/PK

0.72°/0.36°  
PKP/PK

Driver

Accessories

# SH Geared Type Frame Size 90 mm (8 lead wires)

## Specifications

### Motor Specifications

Product Name Single Shaft Double Shaft	Connection Type	Rotor Inertia J: kg·m <sup>2</sup>	Rated Current A/Phase	Voltage VDC	Resistance per Phase Ω/Phase	Inductance mH/Phase	Wirings and Connections (See Page A-431)
<b>PK296AE-SG</b> <span style="border: 1px solid black; padding: 0 2px;"> </span> <b>PK296BE-SG</b> <span style="border: 1px solid black; padding: 0 2px;"> </span>	Bipolar (Parallel)	1400×10 <sup>-7</sup>	4.2	1	0.24	1.5	⑧
	Bipolar (Series)		2.1	2	0.96	6	⑨
	Unipolar		3	1.4	0.48	1.5	⑩

- A number indicating the gear ratio is entered where the box   is located within the product name.
- Backlash value is approximately 1 to 2°.

### Gearmotor Specifications

Product Name Single Shaft Double Shaft	Maximum Holding Torque N·m	Basic Step Angle	Gear Ratio	Permissible Torque N·m	Speed Range r/min
<b>PK296AE-SG3.6</b> <b>PK296BE-SG3.6</b>	2.5	0.5°	3.6	2.5	0~500
<b>PK296AE-SG7.2</b> <b>PK296BE-SG7.2</b>	5	0.25°	7.2	5	0~250
<b>PK296AE-SG9</b> <b>PK296BE-SG9</b>	6.3	0.2°	9	6.3	0~200
<b>PK296AE-SG10</b> <b>PK296BE-SG10</b>	7	0.18°	10	7	0~180
<b>PK296AE-SG18</b> <b>PK296BE-SG18</b>	9	0.1°	18	9	0~100
<b>PK296AE-SG36</b> <b>PK296BE-SG36</b>	12	0.05°	36	12	0~50

- Maximum holding torque is the same regardless of the connection type due to the permissible torque limit of the gearhead.

## Speed – Torque Characteristics

### PK296AE-SG /PK296BE-SG

Bipolar (Series) 24 VDC

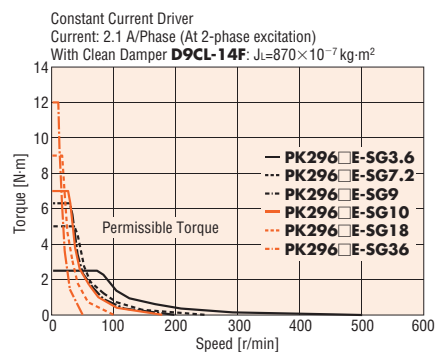

### PK296AE-SG /PK296BE-SG

Bipolar (Series) 48 VDC

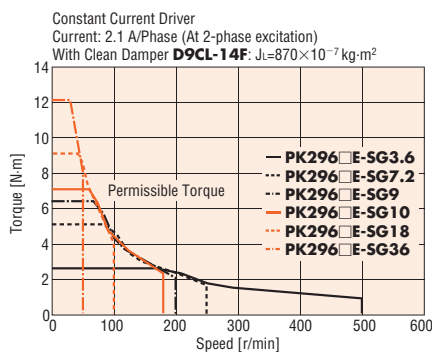

### PK296AE-SG /PK296BE-SG

Unipolar 24 VDC

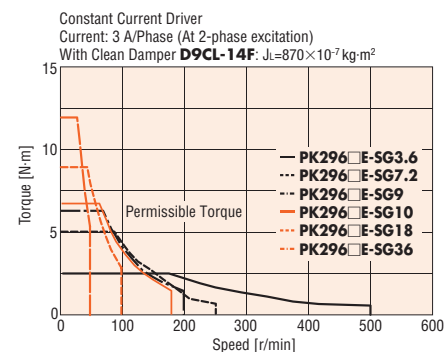

#### Note

- Data for the speed – torque characteristics is based on Oriental Motor's internal measurement conditions. If the conditions are changed, the characteristics may also change as a result.
- If there is a "clean damper" entry in the speed - torque characteristics, the data is for a double shaft motor when a clean damper is equipped.
- Depending on the driving conditions, a considerable amount of heat may be generated by the motor. Be sure to keep the motor case temperature at 100°C or less.

## Dimensions (Unit = mm)

### Motor

Product Name	Gear Ratio	Mass kg
PK296AE-SG <input type="checkbox"/>	3.6, 7.2, 9, 10, 18, 36	2.8
PK296BE-SG <input type="checkbox"/>		

● A number indicating the gear ratio is entered where the box  is located within the product name.

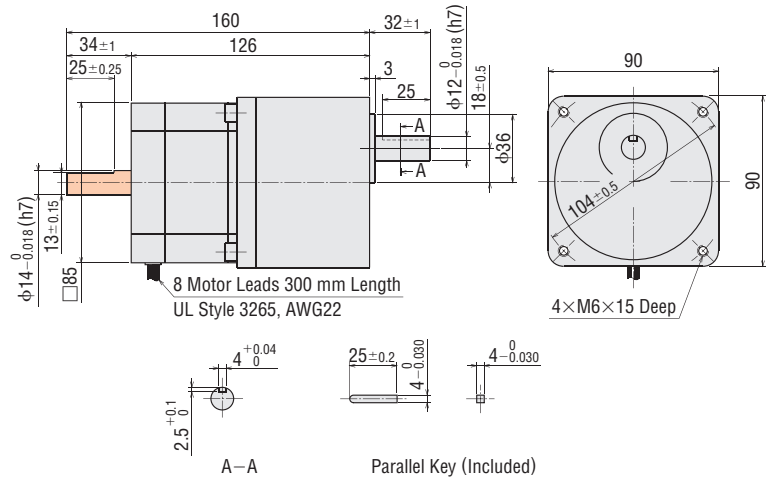

- Included  
Mounting Screws: M6 Length 18 mm×4
- These dimensions are for double shaft models. For single shaft models, ignore the shaft in the shaded  areas.

Overview,  
Product  
Series

AC Input  
Motor &  
Driver

0.36°/Geared  
**αSTEP**  
Absolute  
**AZ**

0.36°/Geared  
**αSTEP**  
**AR**

0.72°/Geared  
**RKII**

DC Input  
Motor &  
Driver

0.36°/Geared  
**αSTEP**  
Absolute  
**AZ**

0.36°/Geared  
**αSTEP**  
**AR**

1.8°/0.72°  
/0.36°  
**CVK**

0.72°/0.36°  
/Geared  
**CRK**

1.8°/Geared  
**RBK**

Motor Only  
/Driver Only

1.8°/0.9°  
**PKP/PK**

Geared  
**PKP/PK**

0.72°/0.36°  
**PKP/PK**

Driver

Accessories

### General Specifications

Specification		Motor
Thermal Class		130(B)
Insulation Resistance		The measured value is 100 MΩ or more when a 500 VDC megger is applied between the windings and the case under normal ambient temperature and humidity.
Dielectric Voltage		No abnormalities are observed, even when applying voltage between the windings and the case for 1 minute under normal ambient temperature and humidity with the following conditions. • Frame size 42 mm max., <b>PKP262</b> : 0.5 kVAC 50/60 Hz • Frame size 50 mm min.: 1.0 kVAC 50/60 Hz • <b>PKP29□</b> , <b>PK29□</b> : 1.5 kVAC 50/60 Hz
Operating Environment (In Operation)	Ambient temperature	-10~+50°C (Non-freezing) [0~+40°C for Flat Type with Harmonic Gear]
	Ambient humidity	85% or less (Non-condensing)
	Atmosphere	No corrosive gases or dust. The product should not be exposed to water, oil or other liquids.
Temperature Rise		Winding temperature rise 80°C max. (Based on Oriental Motor's internal measurement conditions)
Stop Position Accuracy*1		±3 arc minutes (±0.05°) [ <b>PKP21□</b> and <b>PKP262</b> are ±5 arc minutes (±0.083°), <b>PK26□J</b> and <b>PK26□JD</b> are ±2 arc minutes (±0.034°)]
Shaft Runout		0.05 T.I.R. (mm)*4
Radial Play*2		0.025 mm Max. (load 5 N)
Axial Play*3		0.075 mm max. (10 N load) [ <b>PKP21□</b> is 1 N load, <b>PKP22□</b> and <b>PKP262</b> are 2.5 N load]
Concentricity of Installation Pilot to the Shaft		0.075 T.I.R. (mm)*4
Perpendicularity of Installation Surface to the Shaft		0.075 T.I.R. (mm)*4

\*1 This value is for full step under no load. (The value changes with the size of the load.)

\*2 Radial Play: Displacement in shaft position in the radial direction when a 5 N load is applied in the vertical direction to the tip of the motor shaft.

\*3 Axial Play: Displacement in shaft position in the axial direction when a 10 N (**PKP21□** is 1 N, **PKP22□** and **PKP262** are 2.5 N) load is applied to the motor shaft in the axial direction.

\*4 T. I. R. (Total Indicator Reading): The total dial gauge reading when the measurement section is rotated once around the reference axis center.

**Note**

- Do not measure insulation resistance or perform a dielectric strength test while the motor and driver are connected. Also, do not conduct these tests on the motor encoder section.

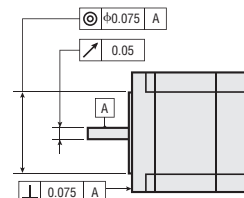

### Electromagnetic Brake Specifications

Product Name	PKP22	PKP23 · PKP24	PKP26	
Type	Power off Activated Type			
Power Supply Voltage	24 VDC ±5%			
Power Supply Current	A	0.05	0.07	0.23
Static Friction Torque	N·m	0.08	0.3	1.5
Brake Activation Time	ms	20		
Brake Release Time	ms	50		
Time Rating	Continuous			

The product names are listed such that the product names are distinguishable.

### Connecting the Electromagnetic Brake

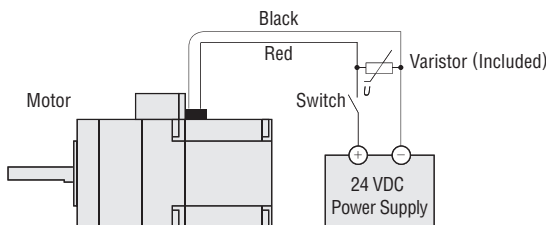

### Encoder Specifications

Encoder Product Name	R2EL	R2FL
Resolution	200P/R	400P/R
Output Circuit Type	Line Driver	
Output Mode	Incremental	
Output Signal	A Phase, B Phase, Z Phase (3 ch)	
Power Supply Voltage	5 VDC ± 10%	
Current	30 mA max.	

A voltage output type of encoder output circuit is also available. For details, please contact your nearest Oriental Motor sales office.



## Permissible Radial Load and Permissible Axial Load

→ Page A-18

## Inner Wiring Diagram of Motor

Wiring Diagram No.	Connection Diagram
①	<p>Bipolar 4 Lead Wires (Products using a compact/flat connector) Connector-Coupled Type</p> <p>Lead Wire Color Connector Terminal Number</p>
②	<p>Bipolar 4 Lead Wires Connector-Coupled Type</p> <p>Lead Wire Color Connector Terminal Number</p>
③	<p>Bipolar 4 Lead Wires Lead Wire Type</p> <p>Lead Wire Color</p>
④	<p>Unipolar 5 Lead Wires Connector-Coupled Type</p> <p>Lead Wire Color Connector Terminal Number</p>
⑤	<p>Unipolar 5 Lead Wires Lead Wire Type</p> <p>Lead Wire Color</p>

Wiring Diagram No.	Connection Diagram
⑥	<p>Unipolar 6 Lead Wires Connector-Coupled Type</p> <p>Lead Wire Color Connector Terminal Number</p>
⑦	<p>Unipolar 6 Lead Wires Lead Wire Type</p> <p>Lead Wire Color</p>
⑧	<p>Parallel Bipolar 8 Lead Wires Lead Wire Type</p> <p>Lead Wire Color</p>
⑨	<p>Series Bipolar 8 Lead Wires Lead Wire Type</p> <p>Lead Wire Color</p>
⑩	<p>Unipolar 8 Lead Wires Lead Wire Type</p> <p>Lead Wire Color</p>

Overview,  
Product  
Series

AC Input  
Motor &  
Driver

0.36°/Geared  
**αSTEP**  
Absolute  
**AZ**

0.36°/Geared  
**αSTEP**  
**AR**

0.72°/Geared  
**RKII**

DC Input  
Motor &  
Driver

0.36°/Geared  
**αSTEP**  
Absolute  
**AZ**

0.36°/Geared  
**αSTEP**  
**AR**

1.8°/0.72°  
/0.36°  
**CVK**

0.72°/0.36°  
/Geared  
**CRK**

1.8°/Geared  
**RBK**

Motor Only  
/Driver Only

1.8°/0.9°  
**PKP/PK**

Geared  
**PKP/PK**

0.72°/0.36°  
**PKP/PK**

Driver

Accessories

# 0.72°/0.36° Stepper Motors PKP Series/PK Series

<Additional Information>  
 • Technical reference → Page H-1  
 • Regulations & Standards → Page I-2

● For detailed information about regulations and standards, please see the Oriental Motor website.



This is a high torque and low vibration stepper motor with a basic step angle of 0.72° (resolution of 500 steps per revolution).

High positioning accuracy is possible through low vibration and reduced noise.

(A separate dedicated driver is required to operate each motor.)

## Features

### High Accuracy

Since the step angle of 0.72°/0.36° Stepper Motor in the **PKP** Series is at 0.72° (high-resolution type at 0.36°) and the stopping accuracy is at ±0.05°, highly accurate positioning is possible. In addition, the stop position accuracy controlled by a microstep driver has almost the same high accuracy as that controlled by a full-step driver.

#### ● General 1.8° Stepper Motor

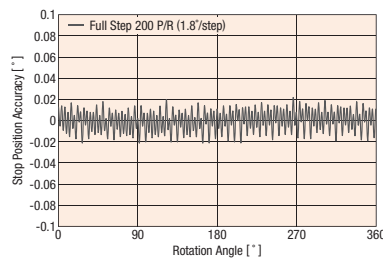

Stopping accuracy gets worse with microstep.

#### ● 0.72°/0.36° Stepper Motor **PKP** Series (Driver: **CVD** driver for 0.72°/0.36° Stepper Motor)

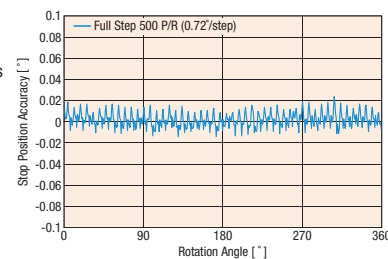

Stopping accuracy does not get worse with microstep.

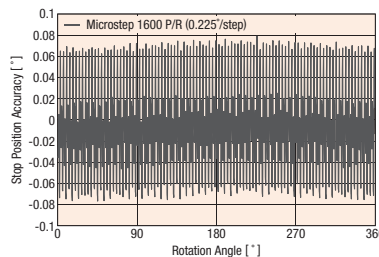

**PKP Series**  
Highly accurate positioning for 0.72°/0.36° Stepper Motor is possible.

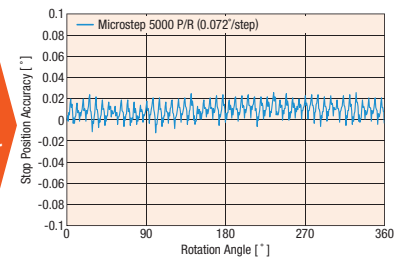

### Low Vibration and Reduced Noise

Because the basic step angle is small at 0.72° (0.36° for high-resolution type), the vibrations and noise are lower than the 1.8° stepper motor with a basic step angle of 1.8°. Also, vibrations and noise can be further reduced through control with the driver of the microstep drive.

#### ● Example of 1.8° Stepper Motor Vibration Characteristics

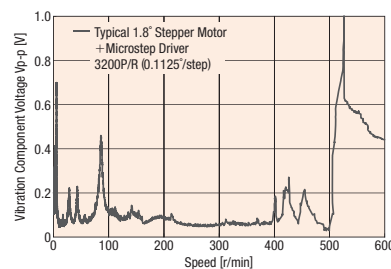





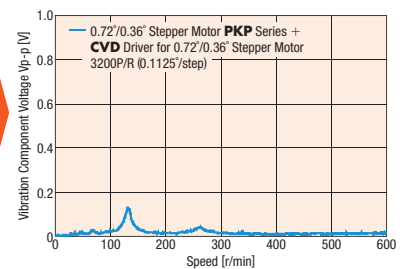







**PKP Series**  
Vibration characteristics for 0.72°/0.36° Stepper Motor have been further improved.

#### ● Example of 0.72°/0.36° Stepper Motor Vibration Characteristics



## Product Line

--: Not Offered in This Product Line

Type	Basic Step Angle	Frame Size					
		20 mm	28 mm	42 mm	56.4 mm	60 mm	85 mm
Standard Type	0.72°						
High-Resolution Type	0.36°	--	--		--		--
Standard Type with Encoder	0.72°		--				--

### ● 0.72°/0.36° Stepper Motor and Driver Package CVK Series

These packages consists of a motor and DC power supply input driver, enabling the performance of the 0.72°/0.36° stepper motor **PKP** Series motor to be maximized.

High-performance 0.72°/0.36° stepper motor and driver packages reduce vibrations and noise by utilizing a digitally-controlled full-time microstep driver.

→ Page A-268

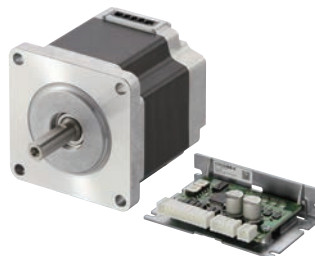

Overview, Product Series

AC Input Motor & Driver

0.36°/Geared  
**αSTEP Absolute AZ**

0.36°/Geared  
**αSTEP AR**

0.72°/Geared  
**RKII**

DC Input Motor & Driver

0.36°/Geared  
**αSTEP Absolute AZ**

0.36°/Geared  
**αSTEP AR**

1.8°/0.72°/0.36°  
**CVK**

0.72°/0.36°/Geared  
**CRK**

1.8°/Geared  
**RBK**

Motor Only / Driver Only

1.8°/0.9°  
**PKP/PK**

Geared  
**PKP/PK**

0.72°/0.36°  
**PKP/PK**

Driver

Accessories

### System Configuration

These accessories allow 0.72°/0.36° stepper motor in the **PKP** Series to be used for various operations.

\* Not supplied.

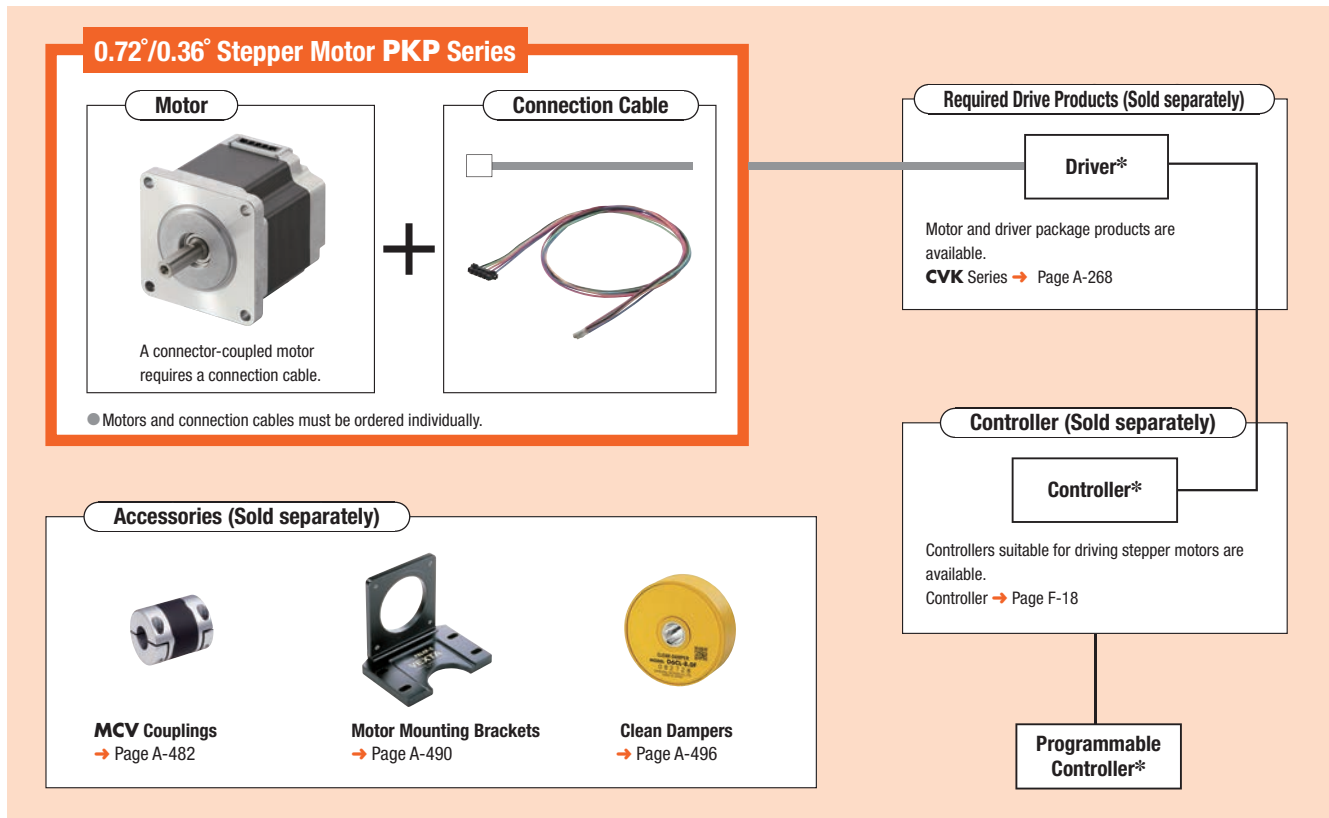

● **Example of System Configuration**

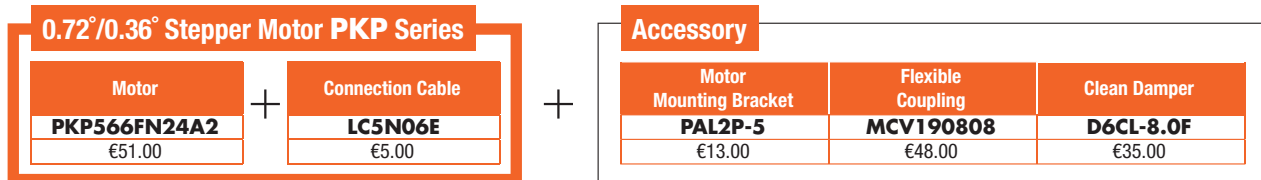

● The system configuration shown above is an example. Other combinations are also available.

## Product Number

### Motor

◇ Frame Size 20 mm, 85 mm

Standard type

**PK 5 1 3 P A**

① ② ③ ④ ⑤ ⑧

**PK 5 9 6 H N A W**

① ② ③ ④ ⑥ ⑦ ⑧ ⑪

Standard Type with Encoder

**PK 5 1 3 P A - R2G L**

① ② ③ ④ ⑤ ⑧ ⑨ ⑩

◇ Frame Size 28 mm, 42 mm, 56.4 mm, 60 mm

Standard Type, High-Resolution Type

**PKP 5 6 6 F N 24 A 2**

① ② ③ ④ ⑤ ⑦ ⑧ ⑨ ⑩

**PKP 5 4 4 M N 18 A**

① ② ③ ④ ⑥ ⑦ ⑧ ⑨

Standard Type with Encoder

**PKP 5 6 6 F N 24 A 2 - R2G L**

① ② ③ ④ ⑤ ⑦ ⑧ ⑨ ⑩ ⑪ ⑫

### Connection Cable

◇ Connection Cable for Motor

**LC 5 N 06 E**

① ② ③ ④ ⑤

◇ Connection Cable for Encoder

**LC E 08 A - 006**

① ② ③ ④ ⑤

①	Series Name	<b>PK: PK Series</b>
②	<b>5: 0.72°/0.36° Stepper Motor</b>	
③	Motor Frame Size	<b>1: 20 mm 9: 85 mm</b>
④	Motor Case Length	
⑤	Motor Classification	
⑥	Motor Type	Blank: Standard Specifications <b>H: High-Speed Specifications</b>
⑦	Number of Lead Wires	<b>N: 5 Leads</b>
⑧	Configuration	<b>A: Single Shaft B: Double Shaft</b>
⑨	Encoder Resolution	<b>R2G: 500 P/R</b>
⑩	Encoder Output Circuit Type	<b>L: Line Driver Output</b>
⑪	Cable Identification	Blank: Connector Connection Method <b>W: Lead Wire Type</b>

①	Series Name	<b>PKP: PKP Series</b>
②	<b>5: 0.72°/0.36° Stepper Motor</b>	
③	Motor Frame Size	<b>2: 28 mm 4: 42 mm</b> <b>6: 56.4 mm</b> (60 mm when the motor classification is "F")
④	Motor Case Length	
⑤	Motor Classification	<b>F: Motor Frame Size of 60 mm</b>
⑥	Motor Type	Blank: Standard Type <b>M: High-Resolution Type</b>
⑦	Number of Lead Wires	<b>N: 5 Leads</b>
⑧	Motor Winding Specifications	
⑨	Configuration	<b>A: Single Shaft B: Double Shaft</b>
⑩	Reference Number	
⑪	Encoder Resolution	<b>R2G: 500 P/R</b>
⑫	Encoder Output Circuit Type	<b>L: Line Driver Output*</b>

\*Encoder of voltage output for output circuit type is also available.  
For details, please contact your nearest Oriental Motor sales office.

①	Cables	<b>LC: Connector-Type Leads</b>
②	<b>5: 0.72°/0.36° Stepper Motor</b>	
③	Cable Type	<b>N: For 0.72°/0.36° Stepper Motor</b>
④	Cable Length	<b>06: 0.6 m 10: 1 m</b>
⑤	Reference Number	

①	Cables	<b>LC: Connector-Type Leads</b>
②	Cable Type	<b>E: For Encoder</b>
③	Applicable Models	<b>08: For Line Driver Output*</b>
④	Reference Number	
⑤	Cable Length	<b>006: 0.6 m</b>

\*A voltage output cable is available.  
For details, please contact your nearest Oriental Motor sales office.

Overview,  
Product  
Series

AC Input  
Motor &  
Driver

0.36°/Geared  
**αSTEP**  
Absolute  
**AZ**

0.36°/Geared  
**αSTEP**  
**AR**

0.72°/Geared  
**RKII**

DC Input  
Motor &  
Driver

0.36°/Geared  
**αSTEP**  
Absolute  
**AZ**

0.36°/Geared  
**αSTEP**  
**AR**

1.8°/0.72°  
/0.36°  
**CVK**

0.72°/0.36°  
/Geared  
**CRK**

1.8°/Geared  
**RBK**

Motor Only  
/Driver Only

1.8°/0.9°  
**PKP/PK**

Geared  
**PKP/PK**

0.72°/0.36°  
**PKP/PK**

Driver

Accessories

## Product Line

### Motor

#### ◇ Standard Type

Product Name (Single Shaft)	List Price	Product Name (Double Shaft)	List Price
<b>PK513PA</b>	€93.00	<b>PK513PB</b>	€97.00
<b>PKP523N12A</b>	€35.00	<b>PKP523N12B</b>	€37.00
<b>PKP525N12A</b>	€41.00	<b>PKP525N12B</b>	€43.00
<b>PKP543N18A2</b>	€35.00	<b>PKP543N18B2</b>	€37.00
<b>PKP544N18A2</b>	€37.00	<b>PKP544N18B2</b>	€39.00
<b>PKP545N18A2</b>	€41.00	<b>PKP545N18B2</b>	€43.00
<b>PKP546N18A2</b>	€43.00	<b>PKP546N18B2</b>	€45.00
<b>PKP564N28A2</b>	€43.00	<b>PKP564N28B2</b>	€45.00
<b>PKP566N28A2</b>	€47.00	<b>PKP566N28B2</b>	€49.00
<b>PKP568N28A2</b>	€59.00	<b>PKP568N28B2</b>	€61.00
<b>PKP564FN24A2</b>	€47.00	<b>PKP564FN24B2</b>	€49.00
<b>PKP564FN38A2</b>	€47.00	<b>PKP564FN38B2</b>	€49.00
<b>PKP566FN24A2</b>	€51.00	<b>PKP566FN24B2</b>	€53.00
<b>PKP566FN38A2</b>	€51.00	<b>PKP566FN38B2</b>	€53.00
<b>PKP569FN24A2</b>	€63.00	<b>PKP569FN24B2</b>	€65.00
<b>PKP569FN38A2</b>	€63.00	<b>PKP569FN38B2</b>	€65.00
<b>PK596HNAW</b>	€107.00	<b>PK596HNBW</b>	€110.00
<b>PK599HNAW</b>	€142.00	<b>PK599HNBW</b>	€146.00
<b>PK5913HNAW</b>	€178.00	<b>PK5913HNBW</b>	€185.00

#### ◇ High-Resolution Type

Product Name (Single Shaft)	List Price	Product Name (Double Shaft)	List Price
<b>PKP544MN18A</b>	€37.00	<b>PKP544MN18B</b>	€39.00
<b>PKP546MN18A</b>	€43.00	<b>PKP546MN18B</b>	€45.00
<b>PKP564FMN24A</b>	€47.00	<b>PKP564FMN24B</b>	€49.00
<b>PKP566FMN24A</b>	€51.00	<b>PKP566FMN24B</b>	€53.00
<b>PKP569FMN24A</b>	€63.00	<b>PKP569FMN24B</b>	€65.00

### ● Connection Cable for Motor

Product Name	Length L (m)	List Price
<b>LC5N06A</b>	0.6	€5.00
<b>LC5N10A</b>	1	€7.00
<b>LC5N06B</b>	0.6	€5.00
<b>LC5N10B</b>	1	€7.00
<b>LC5N06C</b>	0.6	€7.00
<b>LC5N10C</b>	1	€9.00
<b>LC5N06E</b>	0.6	€5.00

### ● Connection Cable for Encoder

#### ◇ For Line Driver Output

Product Name	Length L (m)	List Price
<b>LCE08A-006</b>	0.6	€10.00

## Included

Type	Operating Manual
Common to All Types	1 Set

## Details Including Specifications

The motors specified by the above product names are the same as products in the **CVK** Series. Refer to 0.72°/0.36° stepper motor **CVK** Series (Page A-268) for details on specifications, speed – torque characteristics, dimensions, etc.

#### ◇ Standard Type with Encoder

Product Name	List Price
<b>PK513PA-R2GL</b>	€147.00
<b>PKP543N18A2-R2GL</b>	€85.00
<b>PKP544N18A2-R2GL</b>	€87.00
<b>PKP545N18A2-R2GL</b>	€91.00
<b>PKP546N18A2-R2GL</b>	€93.00
<b>PKP564N28A2-R2GL</b>	€93.00
<b>PKP566N28A2-R2GL</b>	€97.00
<b>PKP568N28A2-R2GL</b>	€109.00
<b>PKP564FN24A2-R2GL</b>	€97.00
<b>PKP564FN38A2-R2GL</b>	€97.00
<b>PKP566FN24A2-R2GL</b>	€101.00
<b>PKP566FN38A2-R2GL</b>	€101.00
<b>PKP569FN24A2-R2GL</b>	€113.00
<b>PKP569FN38A2-R2GL</b>	€113.00

Overview,  
Product  
Series

AC Input  
Motor &  
Driver

0.36°/Geared  
***α*STEP  
Absolute  
AZ**

0.36°/Geared  
***α*STEP  
AR**

0.72°/Geared  
**RK II**

DC Input  
Motor &  
Driver

0.36°/Geared  
***α*STEP  
Absolute  
AZ**

0.36°/Geared  
***α*STEP  
AR**

1.8°/0.72°  
/0.36°  
**CVK**

0.72°/0.36°  
/Geared  
**CRK**

1.8°/Geared  
**RBK**

Motor Only  
/Driver Only

1.8°/0.9°  
**PKP/PK**

Geared  
**PKP/PK**

0.72°/0.36°  
**PKP/PK**

Driver

Accessories