

RoHS RoHS-Compliant

Speed Controller

ES01/ES02



ES01 and **ES02** are speed controllers designed for ultimate ease of use when operating and wiring, focusing on the functions required for speed control. A wide range of speed control motors are available for use with these controllers.

Features

Multi-Functions

Provide the functions necessary for speed control.

- Speed Control 90~1400 r/min (50 Hz)
90~1600 r/min (60 Hz)
- Instantaneous Stop
- Acceleration/deceleration function that enables smooth start and stop

Can Be Used World-Wide

The **ES01/ES02** speed controllers conform to major power-supply specifications world-wide. They are recognized by UL and certified by CSA, while implementing CE Marking under the EMC Directive and low-voltage directive.

Simple Wiring

For easy of wiring the new design provides separate connector terminals for power-supply cables and control-signal lines.

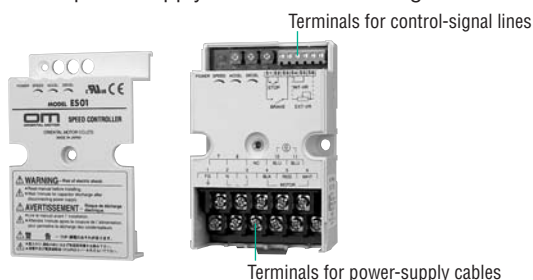

Controlling 6 W to 60 W with a Single Unit

One **ES01/ES02** unit is all you need to operate speed-control motors with varying output of 6 W to 60 W.

IP20-Compliant

The IP20-compliant construction prevents the operator from touching the terminal block, thereby ensuring a high degree of safety.

RoHS-Compliant

ES01/ES02 and the applicable control motors conform to the RoHS Directive, which prohibits the use of six chemical substances including lead and cadmium.

RoHS (Restriction of Hazardous Substances) Directive:
Directive on restriction of the use of certain hazardous substances in electrical and electronic equipment (2002/95/EC). The RoHS Directive prohibits the use of six chemical substances in electrical and electronic products sold in the EU member states. The six controlled substances are: lead, hexavalent chromium, cadmium, mercury and two specific brominated flame-retardants (PBB and PBDE).

Product Line

Speed Controllers **RoHS**

Model	Voltage
ES01	Single-Phase 100-115 VAC
ES02	Single-Phase 200-230 VAC

Safety Standards and CE Marking

Speed Controller **ES01/ES02**

Standards	Certification Body	Standards File No.	CE Marking
UL 508 CSA C22.2 No.14	UL	E91291	Low Voltage Directives EMC Directives
EN 50178 EN 60950-1	Conform to EN Standards		

• The EMC value changes according to the wiring and layout. Therefore, the final EMC level must be checked with the speed controller incorporated in the user's equipment.

Specifications of Speed Controller **RoHS**

Model Name	ES01	ES02
Voltage	Single-Phase 100-115 VAC ±10%	Single-Phase 200-230 VAC ±10%
Frequency	50/60 Hz	
Applicable Speed Control Motor Output	6 W, 15 W, 25 W, 40 W, 60 W	
Variable Speed Range	50 Hz: 90~1400 r/min 60 Hz: 90~1600 r/min	
Function	Speed Control, Instantaneous Stop, Acceleration/Deceleration	
Insulation Resistance	100 MΩ or more when 500 VDC megger is applied between the FG terminal and the power supply terminals, all the pins and the frame under normal temperature and humidity.	
Dielectric Strength	Sufficient to withstand 1.5 kV at 50 Hz, 60 Hz applied between the FG terminals and the power supply terminals for 1 minute, under normal temperature and humidity. Sufficient to withstand 3.0 kVAC at 50 Hz, 60 Hz applied between all the pins and the motor case for 1 minute.	
Ambient Temperature	0~+40°C (non-freezing)	
Ambient Humidity	85% or less (non-condensing)	
Degree of Protection	IP20 (with cover)	

Note:

These models cannot be used for applications requiring the control of more than one motor/controller set by the same external potentiometer. When instantaneous stopping is activated, a large braking current will flow to the motor. → Page 23

System Configuration

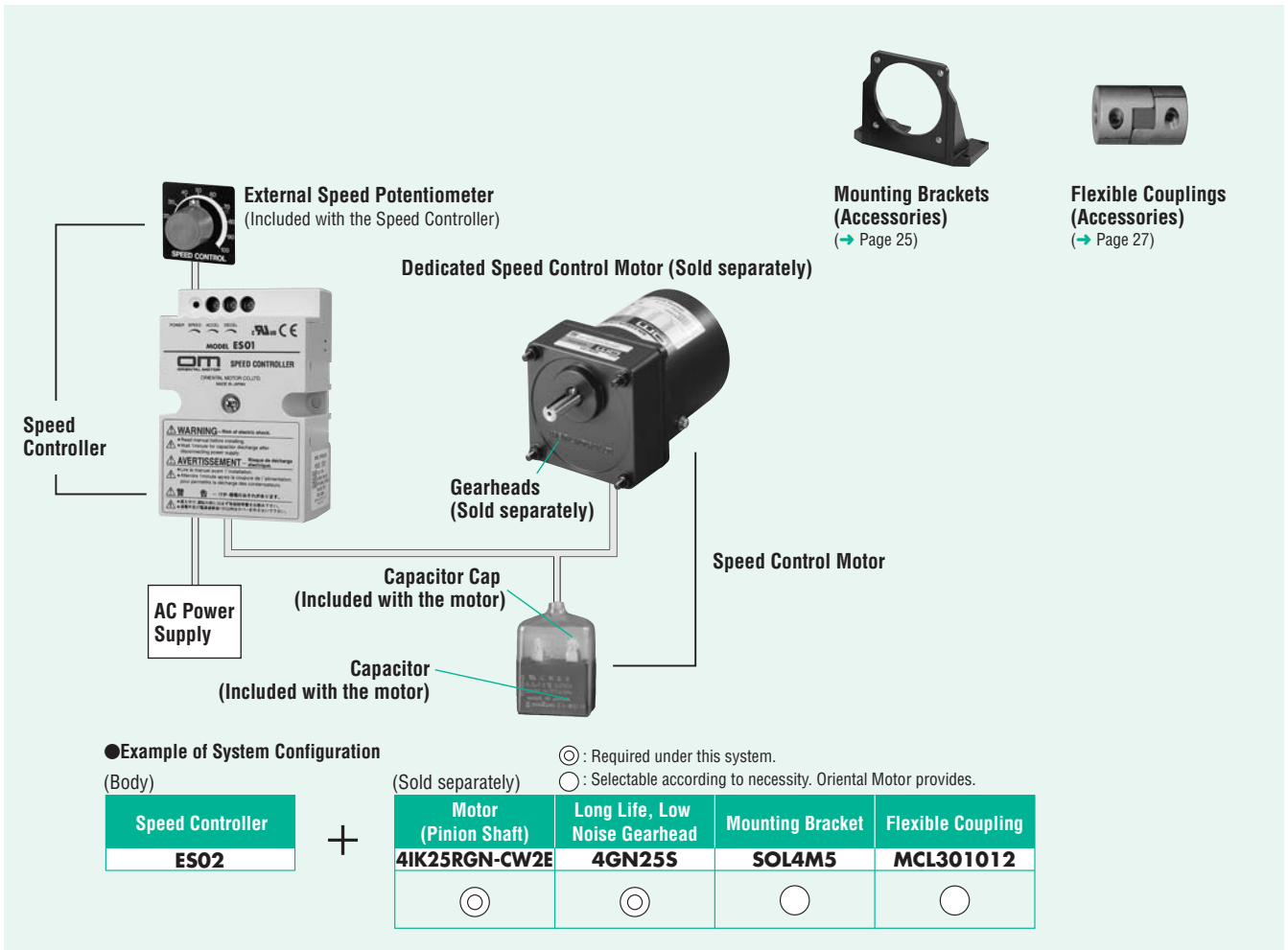

● The system configuration shown above is an example. Other configurations are available.

Applicable Speed Control Motor (Sold separately) (RoHS)



World K Series Speed Control Motor (6 W to 60 W)

Conforming to major global safety standards, the World **K** Series sets the standard for standard AC motors. These motors can be used in wide-ranging applications.

The newly marketed "Long Life, Low Noise **GN-S** Gearhead" realizes a rated life time of 10000 hours, which is twice the life time of conventional products, through new technology and a new construction. These gearheads are highly reliable and require less maintenance.

Product Line → Page 4



Safety Standards and CE Marking

Applicable Speed Control Motor

Standards	Certification Body	Standards File No.	CE Marking
UL 1004 UL 2111	UL	E64199 (6 W Type) E64197 (15 W~60 W Type)	Low Voltage Directives
CSA C22.2 No.100 CSA C22.2 No.77			
EN 60950-1 EN 60034-1 EN 60034-5 IEC 60664-1	Conform to EN Standards		
GB12350*	CQC	2003010401091525 (Single-Phase 6 W) 2003010401091522 (Single-phase 15 W~60 W)	

● When the motor is approved under various safety standards, the model name on the nameplate is the approved model name.

* Those products with a 'G' at the end of their model name are CCC certified for 60 W.

If you require a CCC certified product, please specify a 'G' at the end of the model name you're ordering.

(Example) Model: **5IK60RGU-CWEG**

● For details, please contact the nearest Oriental Motor sales office.

Product Number Code (Applicable Speed Control Motor)

World K Series

Motor

4 I K 25 R GN - AW2 J

① ② ③ ④ ⑤ ⑥ ⑦ ⑧

①	Motor Frame Size	2: 60 mm 3: 70 mm 4: 80 mm 5: 90 mm
②	Motor Type	I: Induction Motor R: Reversible Motor
③	Series	K: K Series
④	Output Power (W)	(Example) 25: 25 W
⑤	Speed Control Motor	
⑥	Motor Shaft Type, Type of Pinion	GN: GN Type Pinion GU: GU Type Pinion A: Round Shaft
⑦	Power Supply Voltage	AW2, AW: Single-Phase 100 VAC, 110/115 VAC, RoHS-Compliant CW2, CW: Single-Phase 200 VAC, 220/230 VAC, RoHS-Compliant
⑧	Included Capacitor	J: Single-Phase 100 VAC, 200 VAC U: Single-Phase 110/115 VAC E: Single-Phase 220/230 VAC

Gearhead

4 GN 50 S

① ② ③ ④

①	Gearhead Frame Size	2: 60 mm 3: 70 mm 4: 80 mm 5: 90 mm
②	Type of Pinion	GN: GN Type Pinion GU: GU Type Pinion
③	Gear Ratio	(Example) 25: Gear Ratio of 1: 25 10X denotes the decimal gearhead of gear ratio 1: 10
④	GN Type Pinion	S: Long Life, Low Noise GN-S Gearhead, RoHS-Compliant RH: Right-Angle, Hollow Shaft Gearhead, RoHS-Compliant RA: Right-Angle, Solid Shaft Gearhead, RoHS-Compliant
	GU Type Pinion	KB: GU Gearhead (Box Type), RoHS-Compliant RH: Right-Angle, Hollow Shaft Gearhead, RoHS-Compliant RA: Right-Angle, Solid Shaft Gearhead, RoHS-Compliant

Product Line (Applicable Speed Control Motor)

World K Series

Pinion Shaft Type (6 W~60 W) (RoHS)

Type	Power Supply Voltage	<input type="checkbox"/> 60 mm 6 W	<input type="checkbox"/> 70 mm 15 W	<input type="checkbox"/> 80 mm 25 W	<input type="checkbox"/> 90 mm 40 W	<input type="checkbox"/> 90 mm 60 W	Applicable Controller (Sold Separately)
		Model	Model	Model	Model	Model	
Induction Motors	Single-Phase 100 VAC	2IK6RGN-AW2J	3IK15RGN-AW2J	4IK25RGN-AW2J	5IK40RGN-AW2J	—	ES01
	Single-Phase 110/115 VAC	2IK6RGN-AW2U	3IK15RGN-AW2U	4IK25RGN-AW2U	5IK40RGN-AW2U	5IK60RGU-AWU	
	Single-Phase 200 VAC	2IK6RGN-CW2J	3IK15RGN-CW2J	4IK25RGN-CW2J	5IK40RGN-CW2J	—	ES02
	Single-Phase 220/230 VAC	2IK6RGN-CW2E	3IK15RGN-CW2E	4IK25RGN-CW2E	5IK40RGN-CW2E	5IK60RGU-CWE	
Reversible Motors	Single-Phase 100 VAC	2RK6RGN-AW2J	3RK15RGN-AW2J	4RK25RGN-AW2J	5RK40RGN-AW2J	—	ES01
	Single-Phase 110/115 VAC	2RK6RGN-AW2U	3RK15RGN-AW2U	4RK25RGN-AW2U	5RK40RGN-AW2U	5RK60RGU-AWU	
	Single-Phase 200 VAC	2RK6RGN-CW2J	3RK15RGN-CW2J	4RK25RGN-CW2J	5RK40RGN-CW2J	—	ES02
	Single-Phase 220/230 VAC	2RK6RGN-CW2E	3RK15RGN-CW2E	4RK25RGN-CW2E	5RK40RGN-CW2E	5RK60RGU-CWE	

Long Life, Low Noise GN-S Gearheads (Sold Separately) (RoHS)

Applicable Motor Output Power (Pinion Shaft)	Gearhead Model	Gear Ratio
6 W	2GN□S	3~180
	2GN10XS (Decimal gearhead)	
15 W	3GN□S	3~180
	3GN10XS (Decimal gearhead)	
25 W	4GN□S	3~180
	4GN10XS (Decimal gearhead)	
40 W	5GN□S	3~180
	5GN10XS (Decimal gearhead)	

● Enter the gear ratio in the box (□) within the model name.

GU Gearheads (Sold Separately) (RoHS)

Applicable Motor Output Power (Pinion Shaft)	Gearhead Model	Gear Ratio
60 W	5GU□KB	3~180
	5GU10XKB (Decimal gearhead)	

● Enter the gear ratio in the box (□) within the model name.

Right-Angle Gearheads (Sold Separately) (RoHS)

Gearhead Type	Applicable Motor Output Power (Pinion Shaft)	Gearhead Model	Gear Ratio
Hollow Shaft	25 W	4GN□RH	3~180
	40 W	5GN□RH	3~180
	60 W	5GU□RH	3~180
Solid Shaft	25 W	4GN□RA	3~180
	40 W	5GN□RA	3~180
	60 W	5GU□RA	3~180

● Enter the gear ratio in the box (□) within the model name.

◇ Round Shaft Type (6 W~60 W) **RoHS**

Type	Power Supply Voltage	□60 mm 6 W	□70 mm 15 W	□80 mm 25 W	□90 mm 40 W	□90 mm 60 W	Applicable Controller (Sold Separately)
		Model	Model	Model	Model	Model	
Induction Motors	Single-Phase 100 VAC	2IK6RA-AW2J	3IK15RA-AW2J	4IK25RA-AW2J	5IK40RA-AW2J	—	ES01
	Single-Phase 110/115 VAC	2IK6RA-AW2U	3IK15RA-AW2U	4IK25RA-AW2U	5IK40RA-AW2U	5IK60RA-AWU	
	Single-Phase 200 VAC	2IK6RA-CW2J	3IK15RA-CW2J	4IK25RA-CW2J	5IK40RA-CW2J	—	ES02
	Single-Phase 220/230 VAC	2IK6RA-CW2E	3IK15RA-CW2E	4IK25RA-CW2E	5IK40RA-CW2E	5IK60RA-CWE	
Reversible Motors	Single-Phase 100 VAC	2RK6RA-AW2J	3RK15RA-AW2J	4RK25RA-AW2J	5RK40RA-AW2J	—	ES01
	Single-Phase 110/115 VAC	2RK6RA-AW2U	3RK15RA-AW2U	4RK25RA-AW2U	5RK40RA-AW2U	5RK60RA-AWU	
	Single-Phase 200 VAC	2RK6RA-CW2J	3RK15RA-CW2J	4RK25RA-CW2J	5RK40RA-CW2J	—	ES02
	Single-Phase 220/230 VAC	2RK6RA-CW2E	3RK15RA-CW2E	4RK25RA-CW2E	5RK40RA-CW2E	5RK60RA-CWE	

Specifications

The following specifications assume combination with an applicable speed control motor.

● World K Series Induction Motors (Continuous Rating)

◇ Single-Phase 100 VAC, 110/115 VAC Applicable Speed Controller: **ES01** **RoHS**



Model		Max. Output W	Voltage VAC	Frequency Hz	Variable Speed Range*1 r/min	Permissible Torque		Starting Torque mN·m	Current A	Power Consumption W	Capacitor μF	
Pinion Shaft Type	Round Shaft Type					1200 r/min	90 r/min					
ZP	2IK6RGN-AW2J	2IK6RA-AW2J	6	Single-Phase 100	50	90~1400	43	45	45	0.280	25	3.5
					60	90~1600	50	41	40			
ZP	2IK6RGN-AW2U	2IK6RA-AW2U	6	Single-Phase 110	60	90~1600	50	34	40	0.270	27	2.5
TP	3IK15RGN-AW2J	3IK15RA-AW2J	15	Single-Phase 100	50	90~1400	110	52	80	0.50	42	5.5
					60	90~1600	125		65		45	
TP	3IK15RGN-AW2U	3IK15RA-AW2U	15	Single-Phase 110	60	90~1600	125	42	65	0.48	46	4.5
TP	4IK25RGN-AW2J	4IK25RA-AW2J	25	Single-Phase 100	50	90~1400	205	60	125	0.75	62	8.0
					60	90~1600					66	
TP	4IK25RGN-AW2U	4IK25RA-AW2U	25	Single-Phase 110	60	90~1600	185	50	120	0.75	58	6.5
											Single-Phase 115	
TP	5IK40RGN-AW2J	5IK40RA-AW2J	40	Single-Phase 100	50	90~1400	275	80	190	1.1	92	11
					60	90~1600			300		200	
TP	5IK40RGN-AW2U	5IK40RA-AW2U	40	Single-Phase 110	60	90~1600	225	67	180	1.1	107	9.0
									Single-Phase 115		200	
TP	5IK60RGU-AWU	5IK60RA-AWU	60	Single-Phase 110	60	90~1600	490	210	320	2.0	180	18

ZP: Impedance protected

TP: Contains a built-in thermal protector (automatic return type). If a motor overheats for any reason, the thermal protector is activated and the motor is stopped. When the motor temperature drops, the thermal protector closes and the motor restarts. Be sure to turn the motor off before inspecting.

*1 The variable speed ranges shown are under no load conditions.

*2 China Compulsory Certification (CCC) System

Those products with a 'G' at the end of their model name are CCC certified for 60 W.

If you require a CCC certified product, please specify a 'G' at the end of the model name you're ordering.

(Example) Model: **5IK60RGU-AWUG**

For details, please contact the nearest Oriental Motor sales office.

◇ Single-Phase 200 VAC, 220/230 VAC Applicable Speed Controller: **ES02** (RoHS)



Model		Max. Output W	Voltage VAC	Frequency Hz	Variable Speed Range*1 r/min	Permissible Torque		Starting Torque mN·m	Current A	Power Consumption W	Capacitor μF				
Pinion Shaft Type	Round Shaft Type					1200 r/min mN·m	90 r/min mN·m								
Ⓜ ZP	2IK6RGN-CW2J	6	Single-Phase 200	50	90~1400	37	44	40	0.130	25	0.8				
				60	90~1600	50	40								
Ⓜ ZP	2IK6RGN-CW2E	6	Single-Phase 220	50	90~1400	36	33	35	0.130	27	0.6				
				60	90~1600	50									
				Single-Phase 230	50	90~1400		40				40			
					60	90~1600		50							
Ⓜ TP	3IK15RGN-CW2J	15	Single-Phase 200	50	90~1400	115	54	80	0.25	42	1.5				
				60	90~1600	125		65		45					
				Single-Phase 220	50	90~1400		110		38		65	43		
					60	90~1600		125				75	46		
Ⓜ TP	3IK15RGN-CW2E	15	Single-Phase 230	50	90~1400	115	38	75	0.23	44	1.0				
				60	90~1600	125		65		47					
				Single-Phase 200	50	90~1400		205		55		120	0.38	67	2.0
					60	90~1600		180							
Ⓜ TP	4IK25RGN-CW2J	25	Single-Phase 220	50	90~1400	205	40	110	0.37	70	1.5				
				60	90~1600	160		120							
				Single-Phase 230	50	90~1400						205			
					60	90~1600		150							
Ⓜ TP	5IK40RGN-CW2J	40	Single-Phase 200	50	90~1400	300	95	200	0.57	94	3.0				
				60	90~1600	320				100					
				Single-Phase 220	50	90~1400		300		75		190	96		
					60	90~1600		280					104		
Ⓜ TP	5IK40RGN-CW2E	40	Single-Phase 230	50	90~1400	320	70	200	0.55	99	2.3				
				60	90~1600	260				105					
				Single-Phase 220	50	90~1400		460		320		0.84	155		
					60	90~1600		490				215	0.89	175	
Ⓜ TP	5IK60RGU-CWE	60	Single-Phase 230	50	90~1400	490	320	170	0.89	158	4.0				
				60	90~1600	180		0.89		172					

Ⓜ **ZP**: Impedance protected

Ⓜ **TP**: Contains a built-in thermal protector (automatic return type). If a motor overheats for any reason, the thermal protector is activated and the motor is stopped. When the motor temperature drops, the thermal protector closes and the motor restarts. Be sure to turn the motor off before inspecting.

*1 The variable speed ranges shown are under no load conditions.

*2 China Compulsory Certification (CCC) System (CCC)

Those products with a "G" at the end of their model name are CCC certified for 60 W.

If you require a CCC certified product, please specify a "G" at the end of the model name you're ordering.

(Example) Model: **5IK60RGU-CWEG**

For details, please contact the nearest Oriental Motor sales office.

● World K Series Reversible Motors (30 Minutes Rating)

◇ Single-Phase 100 VAC, 110/115 VAC Applicable Speed Controller: **ES01** (RoHS)



Model		Max. Output W	Voltage VAC	Frequency Hz	Variable Speed Range*1 r/min	Permissible Torque		Starting Torque mN·m	Current A	Power Consumption W	Capacitor μF
Pinion Shaft Type	Round Shaft Type					1200 r/min mN·m	90 r/min mN·m				
Ⓜ ZP	2RK6RGN-AW2J	6	Single-Phase 100	50	90~1400	45	50	50	0.330	30	4.5
				60	90~1600	50		45			
Ⓜ ZP	2RK6RGN-AW2U	6	Single-Phase 110	60	90~1600	50	50	45	0.320	32	3.5
Ⓜ TP	3RK15RGN-AW2J	15	Single-Phase 100	50	90~1400	115	100	100	0.61	56	7.5
				60	90~1600	125		95			
Ⓜ TP	3RK15RGN-AW2U	15	Single-Phase 110	60	90~1600	125	85	100	0.60	60	6.0
Ⓜ TP	4RK25RGN-AW2J	25	Single-Phase 100	50	90~1400	205	125	155	0.94	87	10
				60	90~1600			140			
Ⓜ TP	4RK25RGN-AW2U	25	Single-Phase 110	60	90~1600	205	110	140	0.93	92	8.0
Ⓜ TP	5RK40RGN-AW2J	40	Single-Phase 100	50	90~1400	320	180	280	1.47	130	16
				60	90~1600			170			
Ⓜ TP	5RK40RGN-AW2U	40	Single-Phase 110	60	90~1600	320	155	240	1.47	145	12
								Single-Phase 115			
Ⓜ TP	5RK60RGU-AWU	60	Single-Phase 110	60	90~1600	490	270	380	2.2	201	20

● The permissible torque and the starting torque of reversible motors are shown without the friction brake installed. Please keep in mind that you should select a suitable motor with enough torque, when designing the equipment.

Ⓜ **ZP**: Impedance protected

Ⓜ **TP**: Contains a built-in thermal protector (automatic return type). If a motor overheats for any reason, the thermal protector is activated and the motor is stopped. When the motor temperature drops, the thermal protector closes and the motor restarts. Be sure to turn the motor off before inspecting.

*1 The variable speed ranges shown are under no load conditions.

*2 China Compulsory Certification (CCC) System (CCC)

Those products with a "G" at the end of their model name are CCC certified for 60 W.

If you require a CCC certified product, please specify a "G" at the end of the model name you're ordering.

(Example) Model: **5RK60RGU-AWUG**

For details, please contact the nearest Oriental Motor sales office.

Model		Max. Output W	Voltage VAC	Frequency Hz	Variable Speed Range*1 r/min	Permissible Torque		Starting Torque mN·m	Current A	Power Consumption W	Capacitor μF					
Pinion Shaft Type	Round Shaft Type					1200 r/min mN·m	90 r/min mN·m									
Ⓟ	2RK6RGN-CW2J	2RK6RA-CW2J	6	Single-Phase 200	50	90~1400	40	50	50	0.155	30	1.0				
					60	90~1600	48		45							
Ⓟ	2RK6RGN-CW2E	2RK6RA-CW2E		Single-Phase 220	50	90~1400	42	50	45	0.155	32	0.8				
					60	90~1600	50		50							
Ⓟ	3RK15RGN-CW2J	3RK15RA-CW2J		15	Single-Phase 230	50	90~1400		46				100	0.31	60	1.8
						60	90~1600		50							
Ⓟ	3RK15RGN-CW2E	3RK15RA-CW2E	Single-Phase 200		50	90~1400	125	125	87	0.30	63	1.5				
					60	90~1600	125		87							
Ⓟ	4RK25RGN-CW2J	4RK25RA-CW2J	25		Single-Phase 220	50	90~1400		205				130	0.52	92	3.0
						60	90~1600						125			
Ⓟ	4RK25RGN-CW2E	4RK25RA-CW2E		Single-Phase 200	50	90~1400	205	115	0.50	95	2.5					
					60	90~1600		110				140				
Ⓟ	5RK40RGN-CW2J	5RK40RA-CW2J		40	Single-Phase 230	50		90~1400				320	200	0.76	135	4.0
						60		90~1600					200			
Ⓟ	5RK40RGN-CW2E	5RK40RA-CW2E	Single-Phase 200		50	90~1400	320	180	0.75	140	3.5					
					60	90~1600		170				270				
Ⓟ	5RK60RGN-CW2J	5RK60RA-CW2J	60		Single-Phase 220	50		90~1400				490	280	1.0	185	5.0
						60		90~1600								
Ⓟ	5RK60RGN-CW2E	5RK60RA-CW2E		Single-Phase 200	50	90~1400	490	280	1.0	188						
					60	90~1600					380	202				
Ⓟ	5RK60RGN-CW2E	5RK60RA-CW2E		Single-Phase 230	50	90~1400			490	280	1.1	202				
					60	90~1600							490	280		

● The permissible torque and the starting torque of reversible motors are shown without the friction brake installed. Please keep in mind that you should select a suitable motor with enough torque, when designing the equipment.

Ⓟ: Impedance protected

Ⓟ: Contains a built-in thermal protector (automatic return type). If a motor overheats for any reason, the thermal protector is activated and the motor is stopped. When the motor temperature drops, the thermal protector closes and the motor restarts. Be sure to turn the motor off before inspecting.

*1 The variable speed ranges shown are under no load conditions.

*2 China Compulsory Certification (CCC) System

Those products with a 'G' at the end of their model name are CCC certified for 60 W.

If you require a CCC certified product, please specify a 'G' at the end of the model name you're ordering.

(Example) Model: **5RK60RGN-CWEG**

For details, please contact the nearest Oriental Motor sales office.

General Specifications of Speed Control Motors

Item	Specifications
Insulation Resistance	100 MΩ or more when 500 VDC megger is applied between the windings and the case after rated operation under normal ambient temperature and humidity.
Dielectric Strength	Sufficient to withstand 1.5 kV at 50 Hz or 60 Hz applied between the windings and the case for 1 minute after rated operation under normal ambient temperature and humidity.
Temperature Rise	Temperature rise of windings are 80°C or less measured by the resistance change method after rated operation under normal ambient temperature and humidity with connecting a gearhead or equivalent heat radiation plate* to a motor.
Insulation Class	Class B (130°C)
Overheat Protection	6 W type has impedance protection. All others have built-in thermal protector (automatic return type). open: 130±5°C, close: 82±15°C
Ambient Temperature	110/115 VAC, 220/230 VAC: -10~+40°C (non-freezing) 100 VAC, 200 VAC: -10~+50°C (non-freezing)
Ambient Humidity	85% or less (non-condensing)
Degree of Protection	6 W, 15 W, 25 W, 40 W : IP20 60 W : IP40

* Heat radiation plate (Material: Aluminum)

Motor Output	Size (mm)	Thickness (mm)
6 W	115×115	5
15 W	125×125	
25 W	135×135	
40 W	165×165	
60 W	200×200	

Variable Speed Range when Gearhead is Attached

Unit = r/min

Gear Ratio	3	3.6	5	6	7.5	9	12.5	15	18	25	30	36	50	60	75	90	100	120	150	180
High 50 Hz	466	388	280	233	186	155	112	93	77	56	46	38	28	23	18	15	14	11	9	7
Speed 60 Hz	533	444	320	266	213	177	128	106	88	64	53	44	32	26	21	17	16	13	10	8.8
Low Speed	30	25	18	15	12	10	7.2	6	5	3.6	3	2.5	1.8	1.5	1.2	1	0.9	0.75	0.6	0.5

Gearmotor – Torque Table

- Gearheads are sold separately.
- To reduce the speed beyond the gear ratio in the table, attach a decimal gearhead (gear ratio: 10, sold separately) between the gearhead and the motor. In that case, the permissible torques are as follows.

2GN□S: 3 N·m, **3GN□S:** 5 N·m

4GN□S: 8 N·m (when a gearhead of 1/25~1/36 is connected, the value for permissible torque is 6 N·m)

5GN□S: 10 N·m, **5GU□KB:** 20 N·m

- Enter the gear ratio in the box (□) within the model name.

- A colored background (□) indicates gear shaft rotation in the same direction as the motor shaft, while the others rotate in the opposite direction.

World K Series Induction Motors

◇ Single-Phase 100 VAC, 110/115 VAC

Unit = N·m

Model Motor/Gearhead	Gear Ratio		3	3.6	5	6	7.5	9	12.5	15	18	25	30	36	50	60	75	90	100	120	150	180	
	Speed																						
2IK6RGN-AW2J /2GN□S	1200 r/min	50 Hz	0.10	0.13	0.17	0.21	0.26	0.31	0.44	0.52	0.63	0.78	0.94	1.1	1.4	1.7	2.1	2.6	2.8	3	3	3	3
		60 Hz	0.12	0.15	0.20	0.24	0.30	0.36	0.51	0.61	0.73	0.91	1.1	1.3	1.7	2.0	2.5	3	3	3	3	3	3
	90 r/min	50 Hz	0.11	0.13	0.18	0.22	0.27	0.33	0.46	0.55	0.66	0.82	0.99	1.2	1.5	1.8	2.2	2.7	3	3	3	3	3
		60 Hz	0.10	0.12	0.17	0.20	0.25	0.30	0.42	0.50	0.60	0.75	0.90	1.1	1.4	1.6	2.0	2.4	2.7	3	3	3	3
2IK6RGN-AW2U /2GN□S	1200 r/min		0.12	0.15	0.20	0.24	0.30	0.36	0.51	0.61	0.73	0.91	1.1	1.3	1.7	2.0	2.5	3	3	3	3	3	
	90 r/min		0.083	0.099	0.14	0.17	0.21	0.25	0.34	0.41	0.50	0.62	0.74	0.89	1.1	1.3	1.7	2.0	2.2	2.7	3	3	
3IK15RGN-AW2J /3GN□S	1200 r/min	50 Hz	0.27	0.32	0.45	0.53	0.67	0.80	1.1	1.3	1.6	2.0	2.4	2.9	3.6	4.4	5	5	5	5	5	5	5
		60 Hz	0.30	0.36	0.51	0.61	0.76	0.91	1.3	1.5	1.8	2.3	2.7	3.3	4.1	5	5	5	5	5	5	5	
	90 r/min		0.13	0.15	0.21	0.25	0.32	0.38	0.53	0.63	0.76	0.95	1.1	1.4	1.7	2.1	2.6	3.1	3.4	4.1	5	5	
	1200 r/min		0.30	0.36	0.51	0.61	0.76	0.91	1.3	1.5	1.8	2.3	2.7	3.3	4.1	5	5	5	5	5	5	5	
3IK15RGN-AW2U /3GN□S	90 r/min		0.10	0.12	0.17	0.20	0.26	0.31	0.43	0.51	0.61	0.77	0.92	1.1	1.4	1.7	2.1	2.5	2.8	3.3	4.2	5	
	1200 r/min		0.50	0.60	0.83	1.0	1.2	1.5	2.1	2.5	3.0	3.7	4.5	5.4	6.8	8	8	8	8	8	8	8	
4IK25RGN-AW2J /4GN□S	90 r/min		0.15	0.17	0.24	0.29	0.36	0.44	0.61	0.73	0.87	1.1	1.3	1.6	2.0	2.4	3.0	3.6	4.0	4.8	5.9	7.1	
	1200 r/min		0.45	0.54	0.75	0.90	1.1	1.3	1.9	2.2	2.7	3.4	4.1	4.9	6.1	7.3	8	8	8	8	8	8	
4IK25RGN-AW2U /4GN□S	90 r/min		0.12	0.15	0.20	0.24	0.30	0.36	0.51	0.61	0.73	0.91	1.1	1.3	1.7	2.0	2.5	3.0	3.3	4.0	5.0	5.9	
	1200 r/min		0.67	0.80	1.1	1.3	1.7	2.0	2.8	3.3	4.0	5.0	6.0	7.2	9.1	10	10	10	10	10	10	10	
5IK40RGN-AW2J /5GN□S	1200 r/min	50 Hz	0.67	0.80	1.1	1.3	1.7	2.0	2.8	3.3	4.0	5.0	6.0	7.2	9.1	10	10	10	10	10	10	10	
		60 Hz	0.73	0.87	1.2	1.5	1.8	2.2	3.0	3.6	4.4	5.5	6.6	7.9	9.9	10	10	10	10	10	10	10	
5IK40RGN-AW2U /5GN□S	90 r/min		0.19	0.23	0.32	0.39	0.49	0.58	0.81	0.97	1.2	1.5	1.8	2.1	2.6	3.2	4.0	4.8	5.3	6.3	7.9	9.5	
	1200 r/min		0.55	0.66	0.91	1.1	1.4	1.6	2.3	2.7	3.3	4.1	4.9	5.9	7.4	8.9	10	10	10	10	10	10	
5IK60RGU-AWU /5GU□KB	90 r/min		0.16	0.20	0.27	0.33	0.41	0.49	0.68	0.81	0.98	1.2	1.5	1.8	2.2	2.7	3.3	4.0	4.4	5.3	6.6	8.0	
	1200 r/min		1.2	1.4	2.0	2.4	3.0	3.6	4.5	5.4	6.4	8.1	9.7	11.6	16.2	19.4	20	20	20	20	20	20	
5IK60RGU-AWU /5GU□KB	90 r/min		0.51	0.61	0.85	1.0	1.3	1.5	1.9	2.3	2.8	3.5	4.2	5.0	6.9	8.3	9.3	11.2	12.4	14.9	18.6	20	
			0.51	0.61	0.85	1.0	1.3	1.5	1.9	2.3	2.8	3.5	4.2	5.0	6.9	8.3	9.3	11.2	12.4	14.9	18.6	20	

◇ Single-Phase 200 VAC, 220/230 VAC

Unit = N·m

Model		Gear Ratio		3	3.6	5	6	7.5	9	12.5	15	18	25	30	36	50	60	75	90	100	120	150	180
Motor/Gearhead		Speed																					
2RK6RGN-CW2J /2GN□S	1200 r/min	50 Hz	0.097	0.12	0.16	0.19	0.24	0.29	0.41	0.49	0.58	0.73	0.88	1.1	1.3	1.6	2.0	2.4	2.6	3	3	3	3
		60 Hz	0.12	0.14	0.19	0.23	0.29	0.35	0.49	0.58	0.70	0.88	1.1	1.3	1.6	1.9	2.4	2.9	3	3	3	3	3
	90 r/min		0.12	0.15	0.20	0.24	0.30	0.36	0.51	0.61	0.73	0.91	1.1	1.3	1.7	2.0	2.5	3	3	3	3	3	3
2RK6RGN-CW2E /2GN□S	1200 r/min	220 VAC 50 Hz	0.10	0.12	0.17	0.20	0.26	0.31	0.43	0.51	0.61	0.77	0.92	1.1	1.4	1.7	2.1	2.5	2.8	3	3	3	3
		230 VAC 50 Hz	0.11	0.13	0.19	0.22	0.28	0.34	0.47	0.56	0.67	0.84	1.0	1.2	1.5	1.8	2.3	2.7	3	3	3	3	3
	60 Hz	0.12	0.15	0.20	0.24	0.30	0.36	0.51	0.61	0.73	0.91	1.1	1.3	1.7	2.0	2.5	3	3	3	3	3	3	3
90 r/min		0.12	0.15	0.20	0.24	0.30	0.36	0.51	0.61	0.73	0.91	1.1	1.3	1.7	2.0	2.5	3	3	3	3	3	3	3
3RK15RGN-CW2J /3GN□S	1200 r/min		0.30	0.36	0.51	0.61	0.76	0.91	1.3	1.5	1.8	2.3	2.7	3.3	4.1	5	5	5	5	5	5	5	5
	90 r/min	50 Hz	0.26	0.31	0.43	0.51	0.64	0.77	1.1	1.3	1.5	1.9	2.3	2.8	3.5	4.2	5	5	5	5	5	5	5
60 Hz		0.23	0.28	0.38	0.46	0.58	0.69	0.96	1.2	1.4	1.7	2.1	2.5	3.1	3.8	4.7	5	5	5	5	5	5	5
3RK15RGN-CW2E /3GN□S	1200 r/min		0.30	0.36	0.51	0.61	0.76	0.91	1.3	1.5	1.8	2.3	2.7	3.3	4.1	5	5	5	5	5	5	5	5
	90 r/min		0.21	0.25	0.35	0.42	0.53	0.63	0.88	1.1	1.3	1.6	1.9	2.3	2.9	3.4	4.3	5	5	5	5	5	5
4RK25RGN-CW2J /4GN□S	1200 r/min		0.50	0.60	0.83	1.0	1.2	1.5	2.1	2.5	3.0	3.7	4.5	5.4	6.8	8	8	8	8	8	8	8	8
	90 r/min	50 Hz	0.32	0.38	0.53	0.63	0.79	0.95	1.3	1.6	1.9	2.4	2.8	3.4	4.3	5.1	6.4	7.7	8	8	8	8	8
		60 Hz	0.30	0.36	0.51	0.61	0.76	0.91	1.3	1.5	1.8	2.3	2.7	3.3	4.1	5.0	6.2	7.4	8	8	8	8	8
4RK25RGN-CW2E /4GN□S	1200 r/min		0.50	0.60	0.83	1.0	1.2	1.5	2.1	2.5	3.0	3.7	4.5	5.4	6.8	8	8	8	8	8	8	8	8
	90 r/min	50 Hz	0.28	0.34	0.47	0.56	0.70	0.84	1.2	1.4	1.7	2.1	2.5	3.0	3.8	4.6	5.7	6.8	7.6	8	8	8	8
		60 Hz	0.27	0.32	0.45	0.53	0.67	0.80	1.1	1.3	1.6	2.0	2.4	2.9	3.6	4.4	5.4	6.5	7.3	8	8	8	8
5RK40RGN-CW2J /5GN□S	1200 r/min		0.78	0.93	1.3	1.6	1.9	2.3	3.2	3.9	4.7	5.8	7.0	8.4	10	10	10	10	10	10	10	10	10
	90 r/min		0.49	0.58	0.81	0.97	1.2	1.5	2.0	2.4	2.9	3.7	4.4	5.3	6.6	7.9	9.9	10	10	10	10	10	10
5RK40RGN-CW2E /5GN□S	1200 r/min		0.78	0.93	1.3	1.6	1.9	2.3	3.2	3.9	4.7	5.8	7.0	8.4	10	10	10	10	10	10	10	10	10
	90 r/min	220 VAC 50 Hz	0.44	0.52	0.73	0.87	1.1	1.3	1.8	2.2	2.6	3.3	3.9	4.7	5.9	7.1	8.9	10	10	10	10	10	10
		230 VAC	0.41	0.50	0.69	0.83	1.0	1.2	1.7	2.1	2.5	3.1	3.7	4.5	5.6	6.7	8.4	10	10	10	10	10	10
5RK60RGU-CWE /5GU□KB	1200 r/min		1.2	1.4	2.0	2.4	3.0	3.6	4.5	5.4	6.4	8.1	9.7	11.6	16.2	19.4	20	20	20	20	20	20	20
	90 r/min		0.68	0.82	1.1	1.4	1.7	2.0	2.6	3.1	3.7	4.6	5.5	6.7	9.2	11.1	12.4	14.9	16.5	19.8	20	20	20

■ Permissible Overhung Load and Permissible Thrust Load

Motor (Round Shaft Type) → Page 24

Gearhead → Page 24

■ Permissible Load Inertia of Gearhead: J

→ Page 24

Speed – Torque Characteristics

● Induction Motor

◇ Single-Phase 100 VAC 100 VAC 50 Hz 100 VAC 60 Hz

2IK6RGN(A)-AW2J/ES01

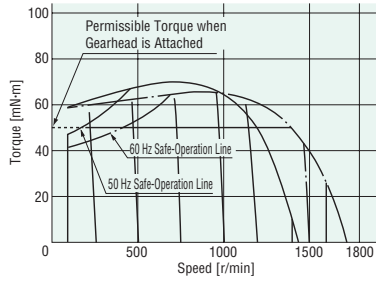

3IK15RGN(A)-AW2J/ES01

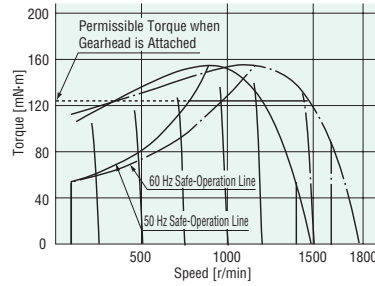

4IK25RGN(A)-AW2J/ES01

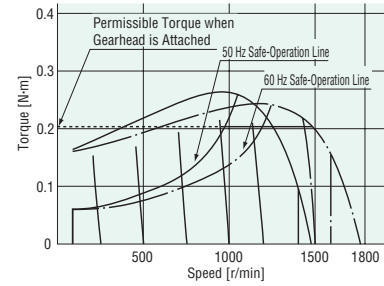

5IK40RGN(A)-AW2J/ES01

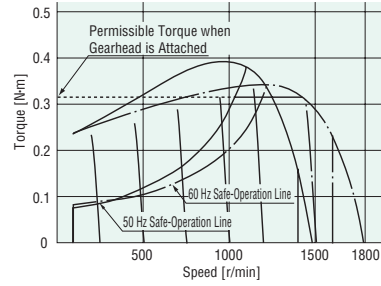

◇ Single-Phase 110/115 VAC 110 VAC 60 Hz 115 VAC 60 Hz

2IK6RGN(A)-AW2U/ES01

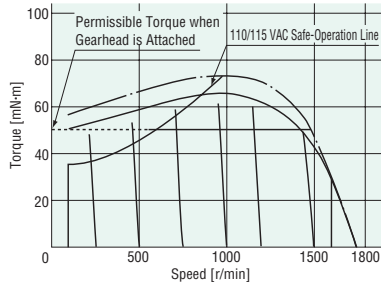

3IK15RGN(A)-AW2U/ES01

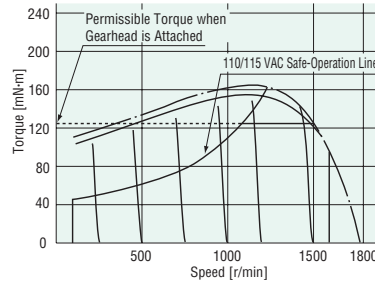

4IK25RGN(A)-AW2U/ES01

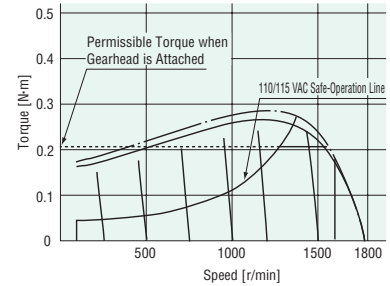

5IK40RGN(A)-AW2U/ES01

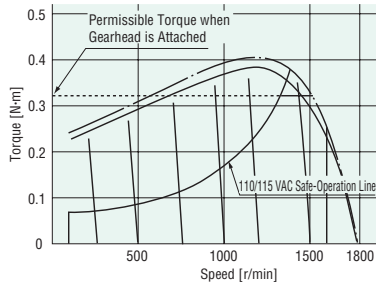

5IK60RGU(A)-AWU/ES01

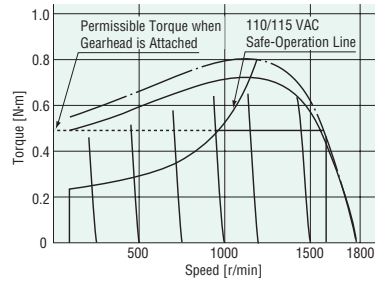

◇ Single-Phase 200 VAC ——— 200 VAC 50 Hz — · — · 200 VAC 60 Hz

2IK6RGN(A)-CW2J/ES02

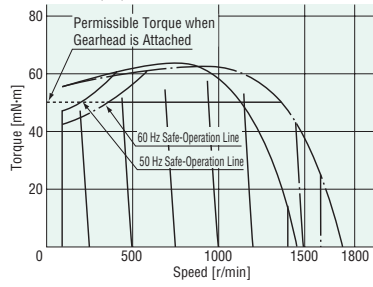

3IK15RGN(A)-CW2J/ES02

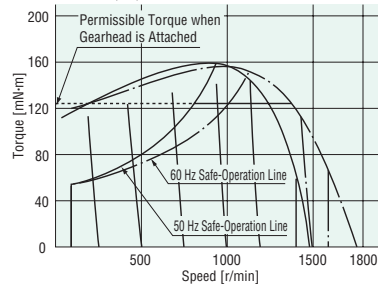

4IK25RGN(A)-CW2J/ES02

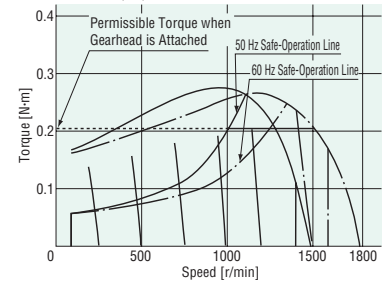

5IK40RGN(A)-CW2J/ES02

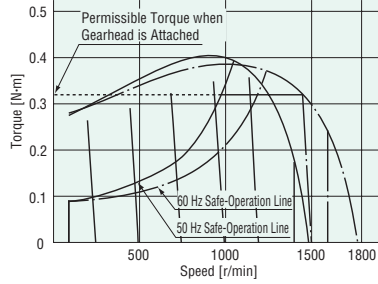

◇ Single-Phase 220/230 VAC ····· 220 VAC 50 Hz ——— 230 VAC 50 Hz — · — · 220 VAC 60 Hz — · — · 230 VAC 60 Hz

2IK6RGN(A)-CW2E/ES02

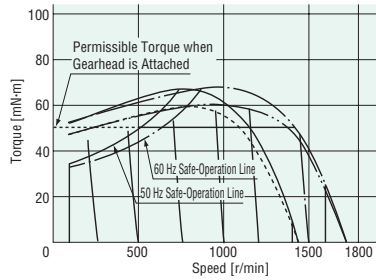

3IK15RGN(A)-CW2E/ES02

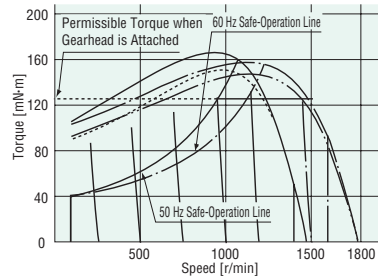

4IK25RGN(A)-CW2E/ES02

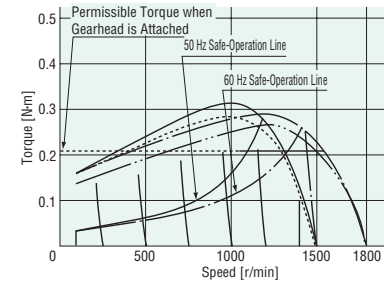

5IK40RGN(A)-CW2E/ES02

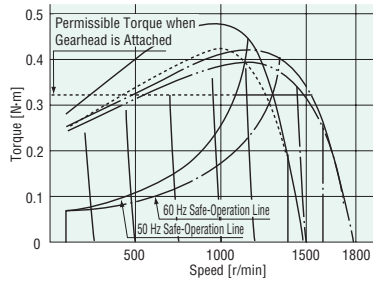

5IK60RGU(A)-CWE/ES02

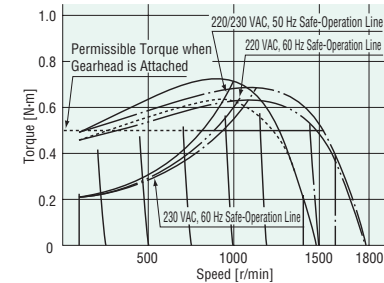

● Reversible Motor

◇ Single-Phase 100 VAC — 100 VAC 50 Hz — · — · 100 VAC 60 Hz

2RK6RGN(A)-AW2J/ES01

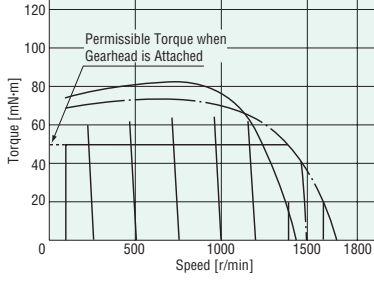

3RK15RGN(A)-AW2J/ES01

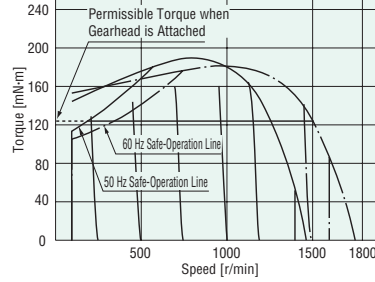

4RK25RGN(A)-AW2J/ES01

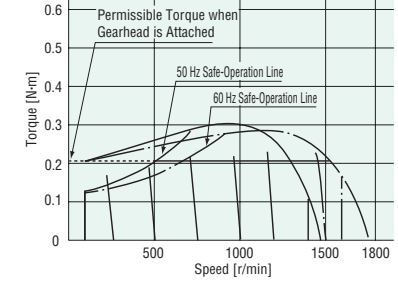

5RK40RGN(A)-AW2J/ES01

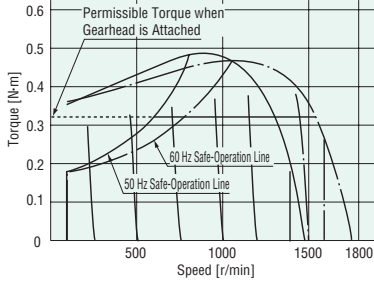

◇ Single-Phase 110/115 VAC — 110 VAC 60 Hz — · — · 115 VAC 60 Hz

2RK6RGN(A)-AW2U/ES01

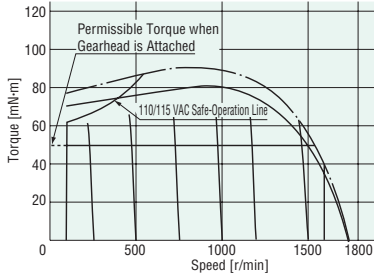

3RK15RGN(A)-AW2U/ES01

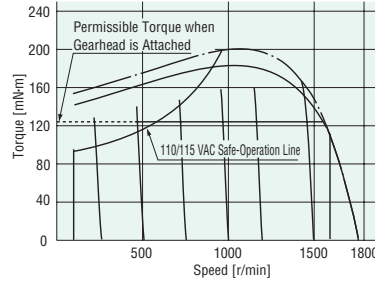

4RK25RGN(A)-AW2U/ES01

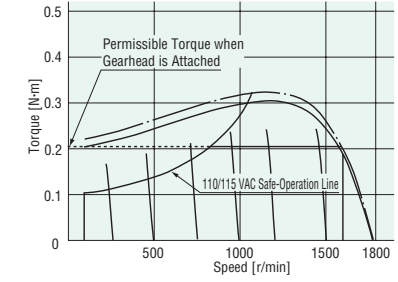

5RK40RGN(A)-AW2U/ES01

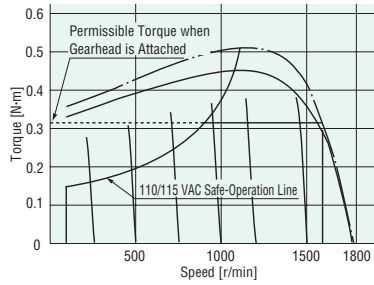

5RK60RGU(A)-AWU/ES01

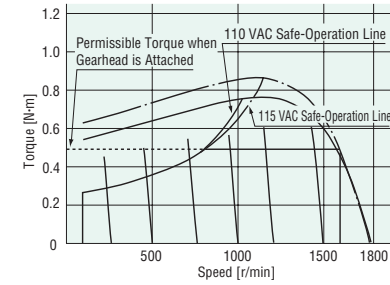

◇ Single-Phase 200 VAC ——— 200 VAC 50 Hz — · — · 200 VAC 60 Hz

2RK6RGN(A)-CW2J/ES02

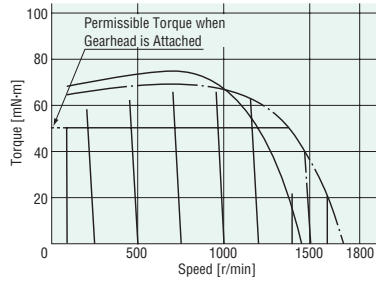

3RK15RGN(A)-CW2J/ES02

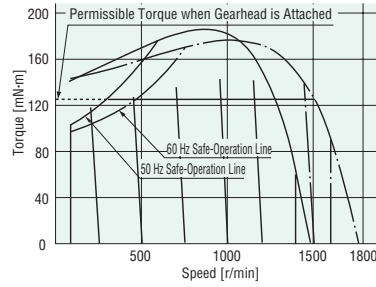

4RK25RGN(A)-CW2J/ES02

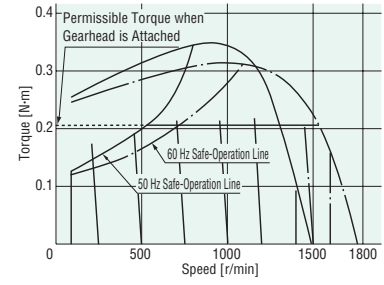

5RK40RGN(A)-CW2J/ES02

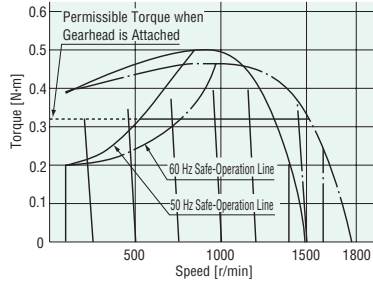

◇ Single-Phase 220/230 VAC · · · · · 220 VAC 50 Hz ——— 230 VAC 50 Hz - - - - 220 VAC 60 Hz - · - · - 230 VAC 60 Hz

2RK6RGN(A)-CW2E/ES02

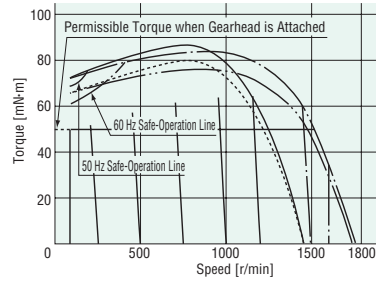

3RK15RGN(A)-CW2E/ES02

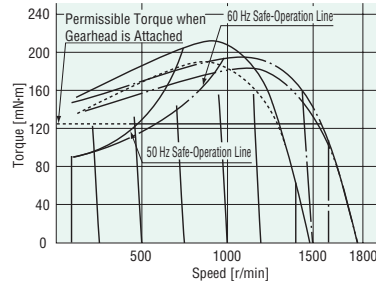

4RK25RGN(A)-CW2E/ES02

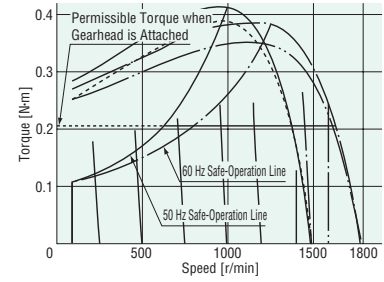

5RK40RGN(A)-CW2E/ES02

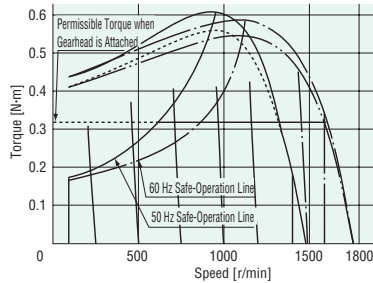

5RK60RGU(A)-CWE/ES02

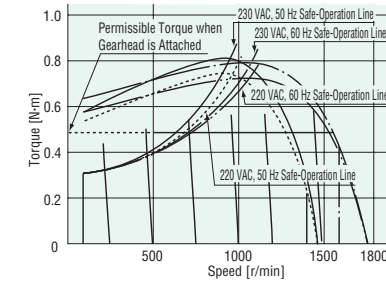

■ Dimensions (Unit = mm)

● Speed Controller

ES01, ES02

Mass: 0.18 kg

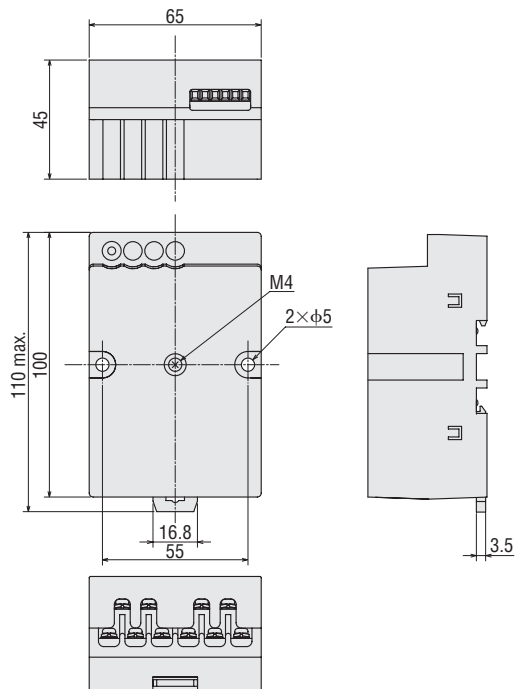

◇ External Speed Potentiometer (included with the Speed Controller)

PAVR-20KZ

Mass: 20 g

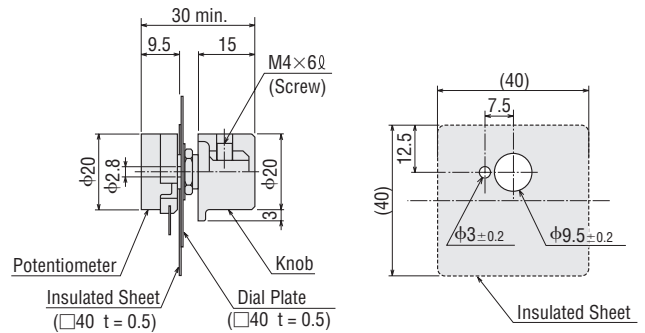

Recommended thickness of a mounting plate is a maximum 4.5 mm.

● World K Series

● Mounting screws are included with gearheads.

◇ Motor/Gearhead

Motor Model	Gearhead Model	Gear Ratio	L1
2IK6RGN-AW2 □	2GN □ S	3~18	30
2IK6RGN-CW2 □			40
2RK6RGN-AW2 □		25~180	30
2RK6RGN-CW2 □			40

Mass: Motor 0.8 kg

Gearhead 0.4 kg

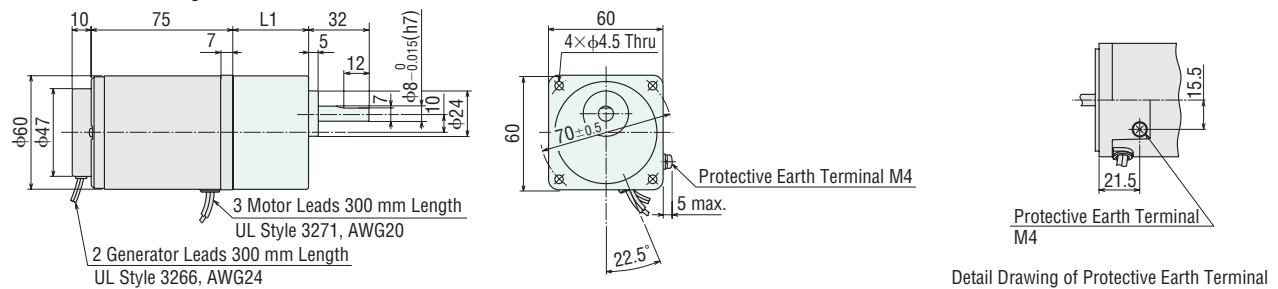

● Specify the type of the capacitor by entering **J**, **U** or **E** in the box (□) within the model name.
Enter the gear ratio in the box (□) within the model name.

◇ Shaft Section of Round Shaft Type

The motor's dimensions (excluding the shaft section) are the same as those of the pinion shaft types.

2IK6RA-AW2 , **2IK6RA-CW2**
2RK6RA-AW2 , **2RK6RA-CW2**

Mass: 0.8 kg

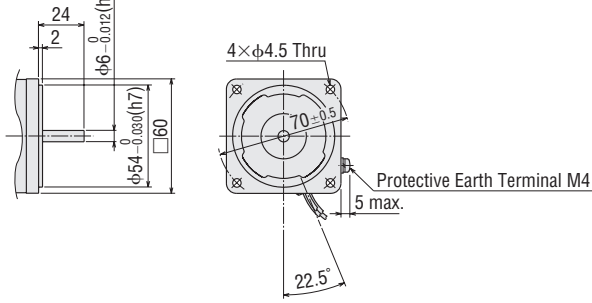

◇ Decimal Gearhead

Can be connected to **GN** pinion shaft type.

2GN10XS

Mass: 0.2 kg

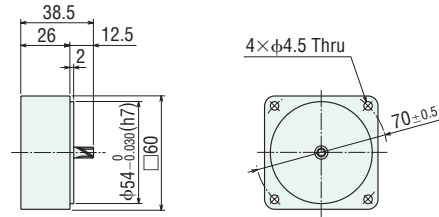

◇ Motor/Gearhead

Motor Model	Gearhead Model	Gear Ratio	L1
3IK15RGN-AW2 <input type="checkbox"/>	3GN <input type="checkbox"/> S	3~18	32
3IK15RGN-CW2 <input type="checkbox"/>		25~180	42
3RK15RGN-AW2 <input type="checkbox"/>			
3RK15RGN-CW2 <input type="checkbox"/>			

Mass: Motor 1.2 kg

Gearhead 0.55 kg

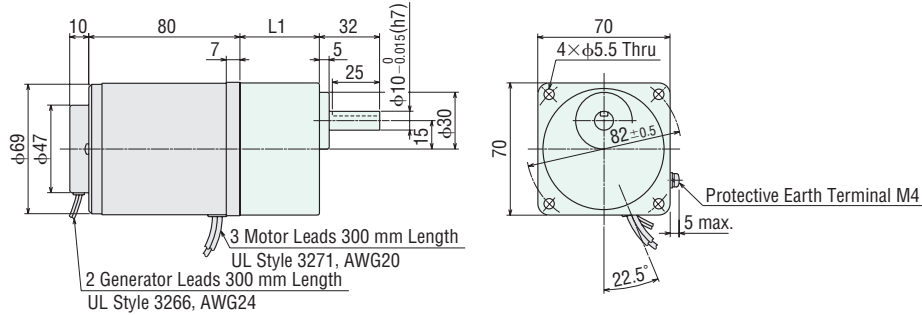

◇ Key and Key Slot

(The key is included with the gearhead)

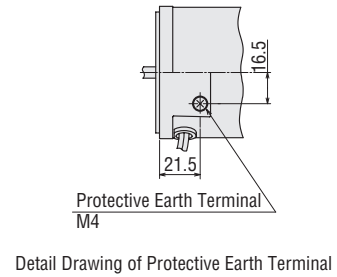
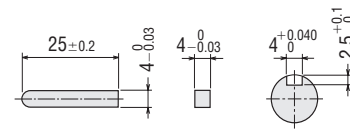

◇ Shaft Section of Round Shaft Type

The motor's dimensions (excluding the shaft section) are the same as those of the pinion shaft types.

3IK15RA-AW2 , **3IK15RA-CW2**
3RK15RA-AW2 , **3RK15RA-CW2**

Mass: 1.2 kg

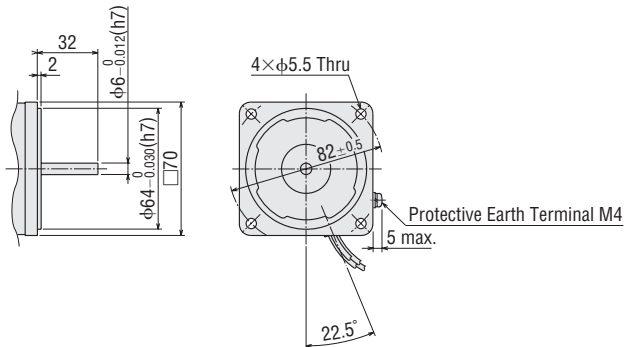

◇ Decimal Gearhead

Can be connected to **GN** pinion shaft type.

3GN10XS

Mass: 0.3 kg

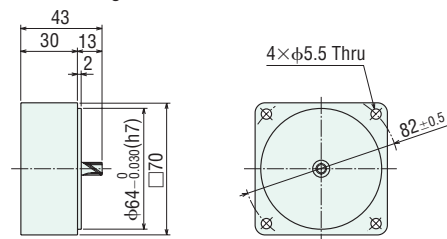

● Specify the type of the capacitor by entering **J**, **U** or **E** in the box () within the model name.
 Enter the gear ratio in the box () within the model name.

◇ Motor/Gearhead

Motor Model	Gearhead Model	Gear Ratio	L1
4IK25RGN-AW2 <input type="checkbox"/> 4IK25RGN-CW2 <input type="checkbox"/> 4RK25RGN-AW2 <input type="checkbox"/> 4RK25RGN-CW2 <input type="checkbox"/>	4GN <input type="checkbox"/> S	3~18	32
25~180		42.5	

Mass: Motor 1.6 kg
Gearhead 0.65 kg

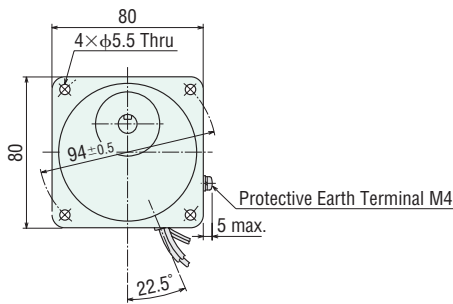
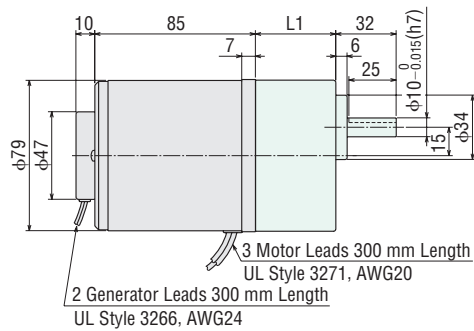

◇ Key and Key Slot

(The key is included with the gearhead)

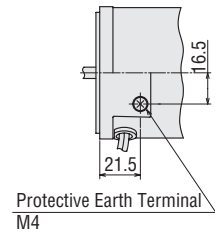
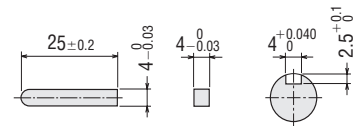

Detail Drawing of Protective Earth Terminal

◇ Shaft Section of Round Shaft Type

The motor's dimensions (excluding the shaft section) are the same as those of the pinion shaft types.

4IK25RA-AW2 , **4IK25RA-CW2**
4RK25RA-AW2 , **4RK25RA-CW2**

Mass: 1.6 kg

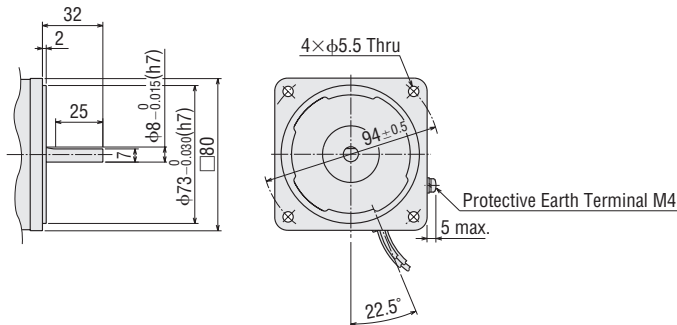

◇ Decimal Gearhead

Can be connected to **GN** pinion shaft type.

4GN10XS

Mass: 0.4 kg

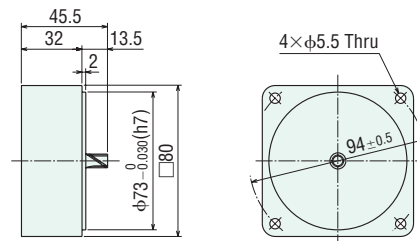

◇ Motor/Gearhead

Motor Model	Gearhead Model	Gear Ratio	L1
5IK40RGN-AW2 <input type="checkbox"/> 5IK40RGN-CW2 <input type="checkbox"/> 5RK40RGN-AW2 <input type="checkbox"/> 5RK40RGN-CW2 <input type="checkbox"/>	5GN <input type="checkbox"/> S	3~18	42
25~180		60	

Mass: Motor 2.6 kg
Gearhead 1.5 kg

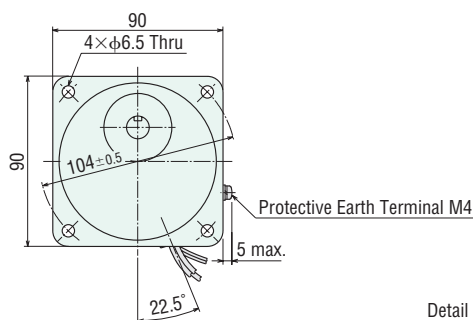
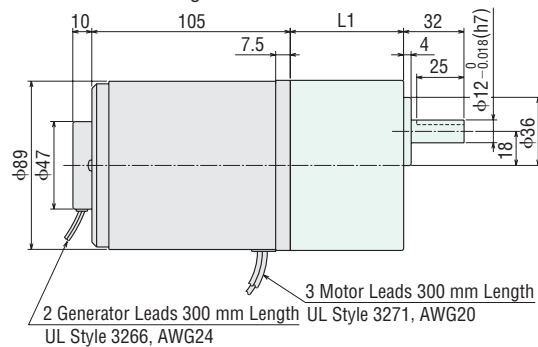

◇ Key and Key Slot

(The key is included with the gearhead)

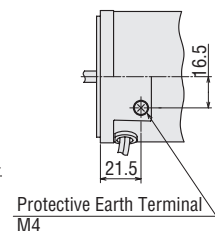
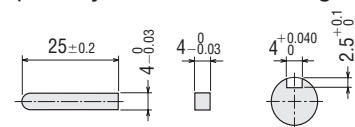

Detail Drawing of Protective Earth Terminal

● Specify the type of the capacitor by entering **J**, **U** or **E** in the box () within the model name.
Enter the gear ratio in the box () within the model name.

◇ Shaft Section of Round Shaft Type

The motor's dimensions (excluding the shaft section) are the same as those of the pinion shaft types.

5IK40RA-AW2 , **5IK40RA-CW2**
5RK40RA-AW2 , **5RK40RA-CW2**

Mass: 2.6 kg

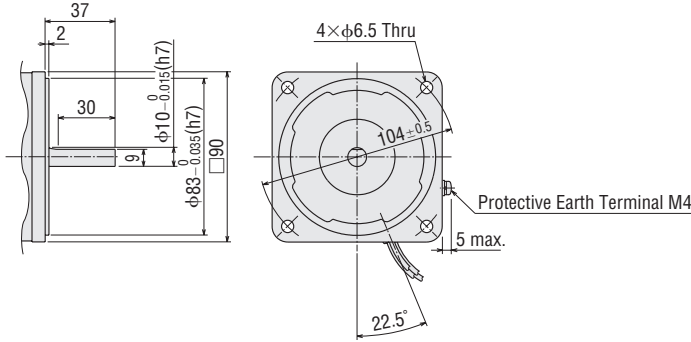

◇ Decimal Gearhead

Can be connected to **GN** pinion shaft type.

5GN10XS

Mass: 0.6 kg

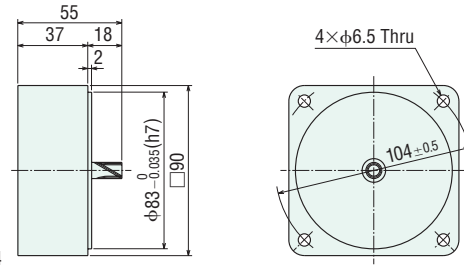

◇ Motor/Gearhead

Motor Model	Gearhead Model	Gear Ratio
5IK60RGU-AWU 5IK60RGU-CWE 5RK60RGU-AWU 5RK60RGU-CWE	5GU <input type="checkbox"/> KB	3-180

Mass: Motor 3.2 kg

Gearhead 1.5 kg

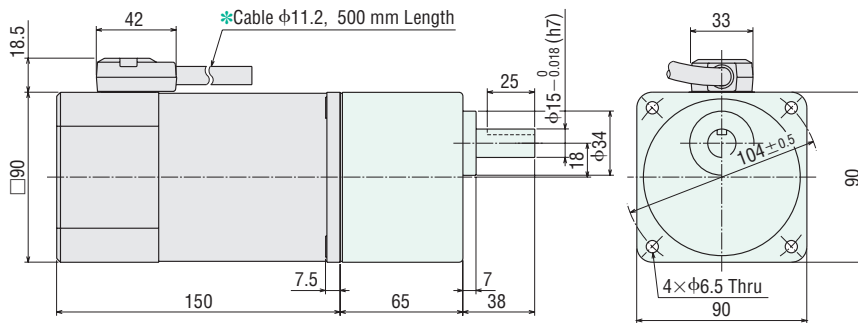

*Conductors

- 3 Motor Leads: UL Style 3266, AWG20
- 2 Fan Leads: UL Style 3266, AWG24
- 2 Generator Leads: UL Style 3266, AWG24

◇ Key and Key Slot (The key is included with the gearhead)

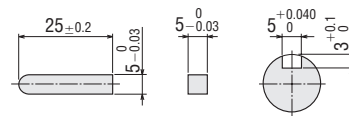

◇ Shaft Section of Round Shaft Type

The motor's dimensions (excluding the shaft section) are the same as those of the pinion shaft types.

5IK60RA-AWU, **5IK60RA-CWE**
5RK60RA-AWU, **5RK60RA-CWE**

Mass: 3.2 kg

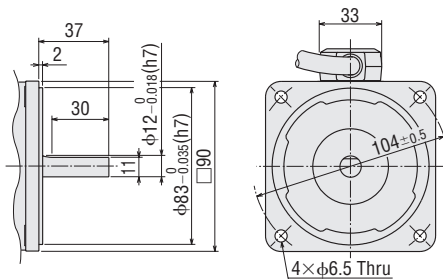

◇ Decimal Gearhead

Can be connected to **GU** pinion shaft type.

5GU10XKB

Mass: 0.6 kg

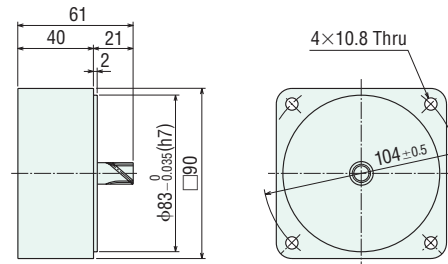

● Specify the type of the capacitor by entering **J**, **U** or **E** in the box within the model name.
 Enter the gear ratio in the box within the model name.

◇ Capacitor (Included with the motor)

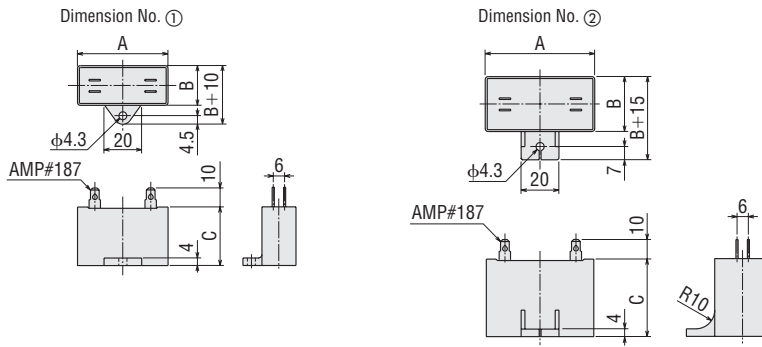

◇ Capacitor Dimensions (unit = mm)

● Induction Motor

Model Pinion Shaft Type	Capacitor Model	Dimensions (mm)			Mass (g)	Dimension No.
		A	B	C		
2IK6RGN-AW2J	CH35FAUL2	31	17	27	25	①
2IK6RGN-AW2U	CH25FAUL2	31	17	27	25	
2IK6RGN-CW2J	CH08BFAUL	31	17	27	20	
2IK6RGN-CW2E	CH06BFAUL	31	14.5	23.5	15	
3IK15RGN-AW2J	CH55FAUL2	38	21	31	40	
3IK15RGN-AW2U	CH45FAUL2	37	18	27	30	
3IK15RGN-CW2J	CH15BFAUL	38	21	31	35	
3IK15RGN-CW2E	CH10BFAUL	37	18	27	30	
4IK25RGN-AW2J	CH80CFAUL2	48	21	31	45	
4IK25RGN-AW2U	CH65CFAUL2	48	19	29	40	
4IK25RGN-CW2J	CH20BFAUL	48	19	29	35	
4IK25RGN-CW2E	CH15BFAUL	38	21	31	35	
5IK40RGN-AW2J	CH110CFAUL2	58	21	31	50	
5IK40RGN-AW2U	CH90CFAUL2	48	22.5	31.5	45	
5IK40RGN-CW2J	CH30BFAUL	58	21	31	50	
5IK40RGN-CW2E	CH23BFAUL	48	21	31	40	
5IK60RGU-AWU	CH180CFAUL	58	23.5	37	70	②
5IK60RGU-CWE	CH40BFAUL	58	23.5	37	70	

- A capacitor cap is included with a capacitor.
- The capacitors for round shaft type motors are the same as those of pinion shaft type motors with the same output and voltage.

● Reversible Motor

Model Pinion Shaft Type	Capacitor Model	Dimensions (mm)			Mass (g)	Dimension No.	
		A	B	C			
2RK6RGN-AW2J	CH45FAUL2	37	18	27	30	①	
2RK6RGN-AW2U	CH35FAUL2	31	17	27	25		
2RK6RGN-CW2J	CH10BFAUL	37	18	27	30		
2RK6RGN-CW2E	CH08BFAUL	31	17	27	20		
3RK15RGN-AW2J	CH75CFAUL2	48	21	31	45		
3RK15RGN-AW2U	CH60CFAUL2	38	21	31	40		
3RK15RGN-CW2J	CH18BFAUL	38	21	31	35		
3RK15RGN-CW2E	CH15BFAUL	38	21	31	35		
4RK25RGN-AW2J	CH100CFAUL2	58	21	31	50		
4RK25RGN-AW2U	CH80CFAUL2	48	21	31	45		
4RK25RGN-CW2J	CH30BFAUL	58	21	31	50		
4RK25RGN-CW2E	CH25BFAUL	48	21	31	45		
5RK40RGN-AW2J	CH160CFAUL2	58	23.5	37	75		②
5RK40RGN-AW2U	CH120CFAUL2	58	22	35	60		①
5RK40RGN-CW2J	CH40BFAUL	58	23.5	37	70	②	
5RK40RGN-CW2E	CH35BFAUL	58	22	35	55	①	
5RK60RGU-AWU	CH200CFAUL	58	29	41	95	②	
5RK60RGU-CWE	CH50BFAUL	58	29	41	85		

- A capacitor cap is included with a capacitor.
- The capacitors for round shaft type motors are the same as those of pinion shaft type motors with the same output and voltage.

Connection and Operation

Names and Functions of Speed Controller Parts

The illustration shows the cover removed. Install the cover after connection.
Figures in parentheses represent pin numbers.

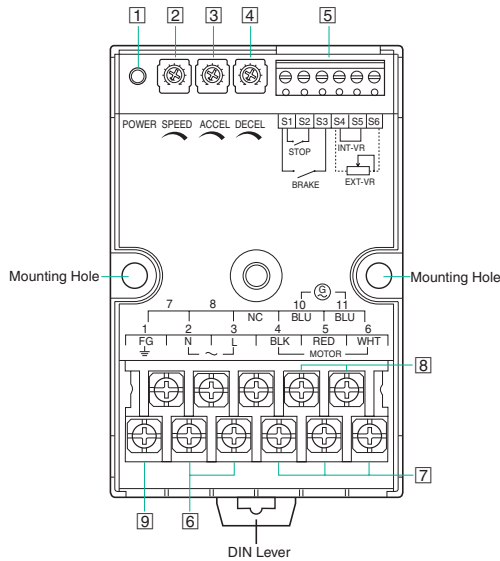

- 1 **POWER LED (POWER)**
Turns on (green) while power is being supplied.
- 2 **Internal speed potentiometer (SPEED)**
Sets the motor's operating speed.
- 3 **Acceleration time potentiometer (ACCEL)**
Sets the acceleration time for motor startup.
- 4 **Deceleration time potentiometer (DECEL)**
Sets the deceleration time for motor stop.
- 5 **Control input terminal**
S1 Common terminal for running and braking
S2 Run/Stop input
Runs (OFF) or stops (ON) the motor.
S3 Run/Brake input
Runs (OFF) or brakes (ON) the motor.
S4, S5, S6 Speed potentiometer inputs
When S4 and S5 are shorted, the speed can be set using the internal speed potentiometer (INT-VR).
When S4 and S5 are open, the speed can be set using an external speed potentiometer (EXT-VR).
When using an external speed potentiometer, connect it to S4 and S6.
- 6 **Power connection terminal (terminals 2 and 3)**
- 7 **Motor connection terminal (terminals 4, 5 and 6)**
- 8 **Generator connection terminal (terminals 10 and 11)**
- 9 **FG terminal (terminal 1)**

Connection Diagrams

Uni-Directional Operation

(When using internal speed potentiometer)

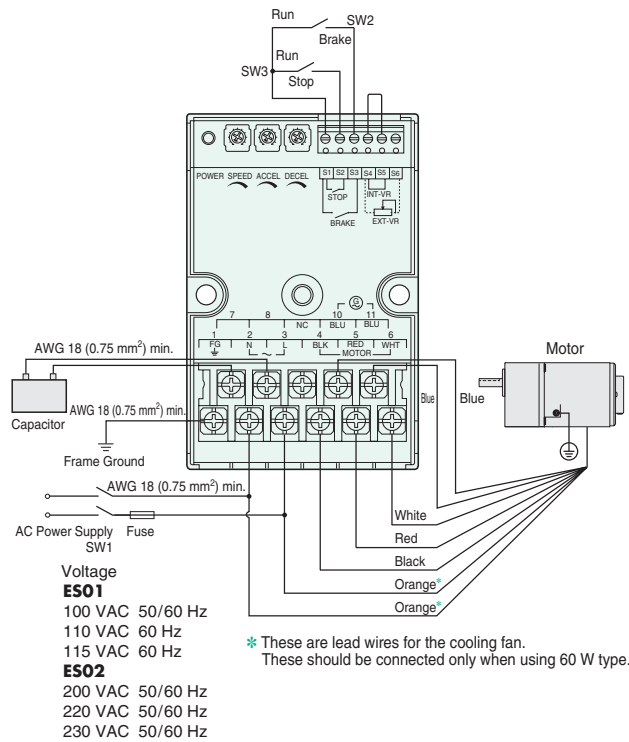

* These are lead wires for the cooling fan.
These should be connected only when using 60 W type.

● For uni-directional operation, connect the red lead to motor connection terminal 5, and the white lead to terminal 6. In this case, the motor rotates in the clockwise direction, as seen from the motor's output-shaft side.

If you connect the white lead to terminal 5, and the red lead to terminal 6, the motor rotates in the counterclockwise direction, as seen from the motor's output-shaft side.

● When using external speed potentiometer, see page 22.

Bi-Directional Operation

(When using internal speed potentiometer)

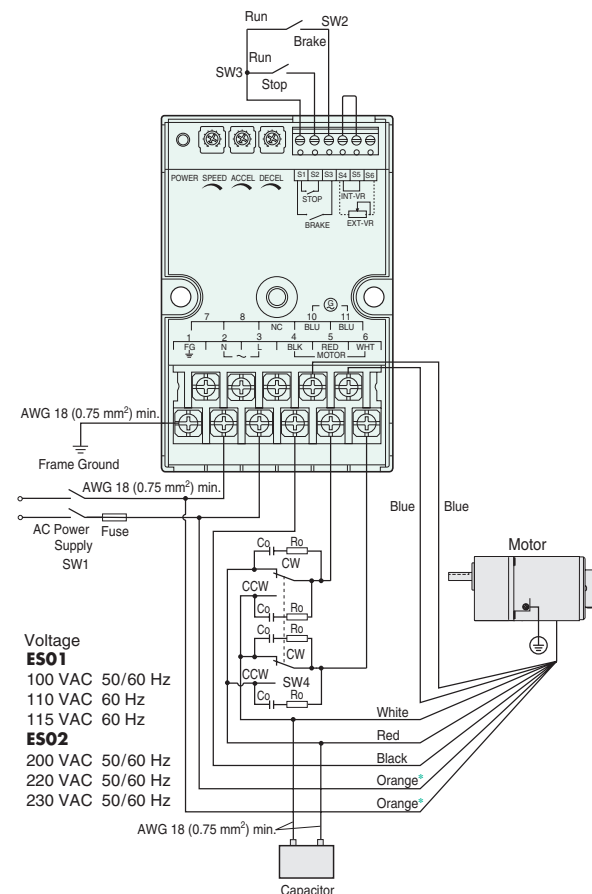

* These are lead wires for the cooling fan.
These should be connected only when using 60 W type.

Specifications of the Switches and Fuse

Power Supply Voltage	100/110/115 VAC (ES01)	200/220/230 VAC (ES02)
SW1	125 VAC 10 A	250 VAC 5 A
SW2, SW3	18 VDC 1 mA	
SW4	125 VAC 10 A	250 VAC 5 A
R ₀ , C ₀ (Surge suppressor)	R ₀ =5~200 Ω, C ₀ =0.1~0.2 μF, 200 W	R ₀ =5~200 Ω, C ₀ =0.1~0.2 μF, 400 W
Fuse	Product certified under the UL/CSA248-14 standard or equivalent. 250 VAC 10 A	

Notes:

● The control input terminals are not insulated from the AC power supply. Any equipment (programmable controller, relay and/or switch) that will be connected to the control input terminals must have contact ratings of 18 VDC and 1 mA min. Do not use a transistor output type controller.

● The length of the cable connecting the motor and speed controller should be no more than 10 m. The length of the control cable should be no more than 2 m and as short as possible.

● Connect a surge suppressor across SW4. Oriental Motor also provides an optional **EPCR1201-2** CR circuit for surge suppression. → Page 27

● Timing Chart

The timing chart below shows an example of switching between two speed levels when the high speed and low speed are selected via the internal and external speed potentiometers, respectively.

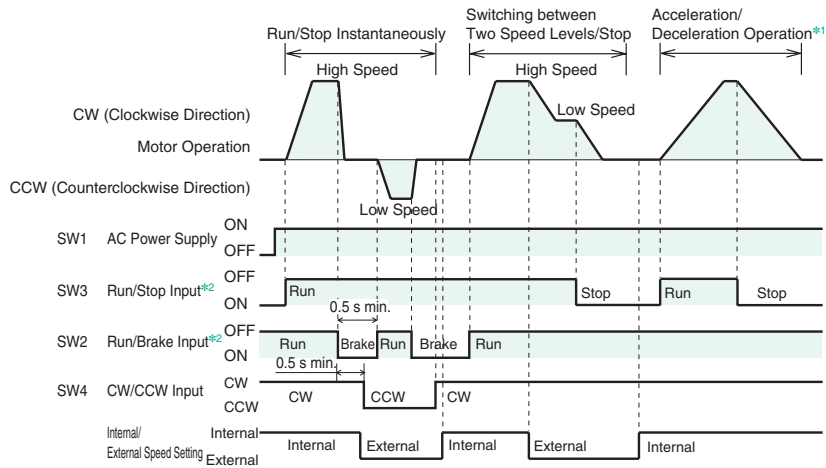

*1 Case where the acceleration and deceleration times are set longer by turning each potentiometer clockwise.

*2 In case SW2 and SW3 are turned on at the same time, Brake Input (SW2) is given priority.

◇ Run/Brake, Stop

Setting SW2/SW3 to “Run” (OFF) causes the motor to rotate at the speed set via the speed potentiometers.

Setting SW2 to “Brake” (ON) during operation causes the motor to stop instantaneously.

Setting SW3 to “Stop” (ON) during operation causes the motor to coast to a stop.

Run/Stop Input	Run/Brake Input	Motor Operation
OFF	OFF	Run
OFF	ON	Instantaneous Stop
ON	OFF	Coasts to a Stop*

* The deceleration time set with a potentiometer is longer than the time which motor coasts to a stop, motor will stop with deceleration time.

The braking function (current through the motor) is only active for approximately 0.4 seconds after the Run/Brake input is turned ON. Do not switch over to SW2, SW3, SW4 within 0.5 seconds, otherwise damage to the speed controller may be resulted.

◇ Switching the Direction of Rotation

SW4 is used to switch the motor’s direction of rotation. When SW4 is set to CW, the motor rotates in the clockwise direction, as seen from the motor’s output-shaft side. When SW4 is set to CCW, the motor rotates in the counterclockwise direction, as seen from the motor’s output-shaft side.

- Be sure to connect a surge suppressor to SW4. Failure to do so may damage the speed controller. Oriental Motor also provides an optional **EPCR1201-2** CR circuit for surge suppression. → Page 27
- Instant switching between forward and reverse operation is possible with a reversible motor.
- For bi-directional operation of an induction motor, switch the rotating direction after the motor has come to a complete stop.

● Speed Setting Methods

The following two methods of setting speed can be used. Multi-motor control or DC voltage control cannot be used.

◇ Internal Speed Potentiometer

The setting range is from 90 to 1400 r/min at 50 Hz or 90 to 1600 r/min at 60 Hz.

Short the speed potentiometer input terminals S4 and S5. Turning the potentiometer clockwise will set a faster speed. The factory setting is 0 r/min.

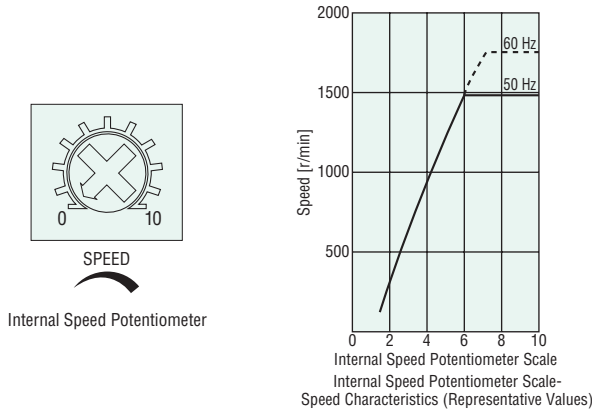

◇ External Speed Potentiometer (included)

Open the speed potentiometer input terminals S4 and S5. Before connecting, turn the dial on the external speed potentiometer counterclockwise to set the speed to 0 r/min. Turning the dial clockwise will set a faster speed.

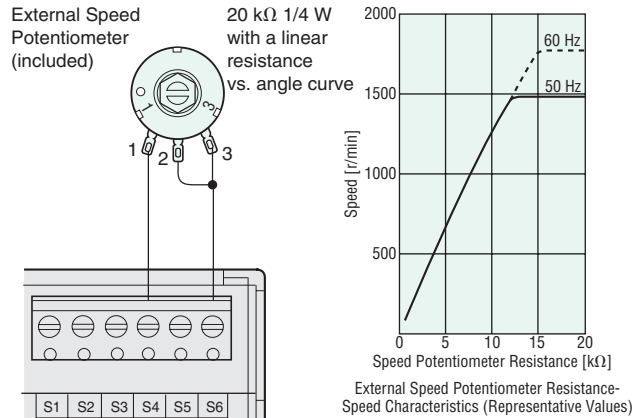

Note: Do not operate multiple speed controllers with a single external speed potentiometer. Doing so may damage the speed controllers.

● Two-Level Speed Control

The motor can be controlled over two speed levels by switching between the internal and external speed potentiometers. Setting SW (speed-setting selection) selects the internal speed potentiometer or external speed potentiometer.

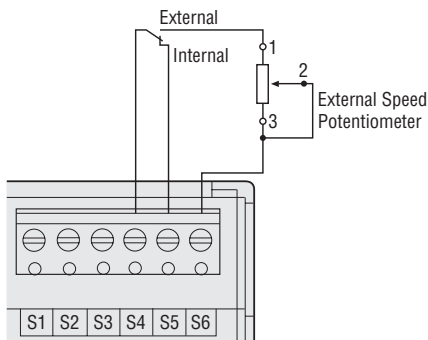

Note: The control input terminals are not insulated from the AC power supply. Any equipment (programmable controller, relay and/or switch) that will be connected to the control input terminals must have contact ratings of 18 VDC and 1 mA min. Do not use a transistor output type programmable controller.

● Acceleration and Deceleration Operation

Equipment and loads are subject to large acceleration/deceleration force when starting, stopping, and changing speeds. When you want to accelerate/decelerate without any accompanying shock, the acceleration/deceleration time can be extended using the acceleration/deceleration function. The acceleration/deceleration time can be set using acceleration/deceleration time potentiometers built into the controller. The setting range is approx. 0.5 to 10 seconds (at 1000 r/min, with no inertial load).

However, when the load inertia is large, the deceleration time cannot be set at a shorter time than when the motor is stopped naturally.

◇ Acceleration

The acceleration function is activated at start or when the speed is switched to the higher setting in a two-level speed control.

Turning the acceleration time potentiometer clockwise will increase the set time.

The factory setting is 0 (no acceleration) .

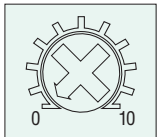

ACCEL

Acceleration Time Potentiometer

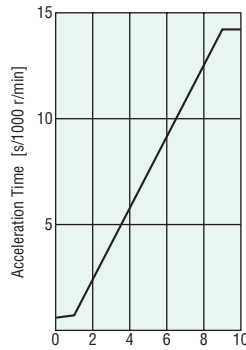

Acceleration Time Potentiometer Scale - Speed characteristics (Representative Values)

◇ Deceleration

The deceleration function is activated during natural stop or when the speed is switched to the lower setting in a two-level speed control.

Turning the deceleration time potentiometer clockwise will increase the set time.

The factory setting is 0 (no deceleration) .

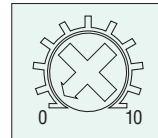

DECEL

Deceleration Time Potentiometer

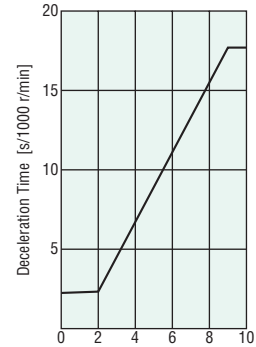

Deceleration Time Potentiometer Scale - Speed characteristics (Representative Values)

● Repeated Operation/Braking Cycle

When running/braking of the motor is repeated in short cycles, the motor temperature rise will increase and the continuous-operation time will be limited. Use the following values as shown below.

The motor may generate heat depending on the conditions in which it is driven. Ensure that the temperature of the motor case does not exceed 90°C.

Motor Output	Repetition Cycle
6 W ~ 40 W	2 seconds min. (Running 1 second, stopping 1 second)
60 W	4 seconds min. (Running 2 seconds, stopping 2 seconds)

● Braking Current

● When the motor is controlled to stop instantaneously, the following braking current will flow. When attaching a circuit protector (breaker or fuse) to a line carrying this type of braking current, refer to the braking value (peak value) in the table to select a device with the appropriate capacity.

● Be careful that repeated motor operation and braking may cause the motor's temperature to rise.

Motor Output	Braking Current (Peak Value) [A]	
	Single-Phase 100 VAC, 110/115 VAC	Single-Phase 200 VAC, 220/230 VAC
6 W	1.5	1.0
15 W	3.5	2.0
25 W	5.5	4.0
40 W	8.5	6.0
60 W	15.5	8.0

Common Specifications

■ Permissible Overhung Load and Permissible Thrust Load of Motors

● Permissible Overhung Load

Motor		Permissible Overhung Load N	
Motor Frame Size □ (mm)	Output Shaft Diameter φ (mm)	Distance from Shaft End	
		10 mm	20 mm
60	6	50	110
70	6	40	60
80	8	90	140
90	10	140	200
90	12	240	270

● Permissible Thrust Load

Avoid thrust loads as much as possible. If thrust load is unavoidable, keep it to half or less of the motor mass.

■ Permissible Overhung Load and Permissible Thrust Load of Gearheads

Model	Gear Ratio	Max. Permissible Torque N·m	Permissible Overhung Load N		Permissible Thrust Load N
			10 mm from shaft end	20 mm from shaft end	
2GN□S	3~18	3	50	80	30
	25~180		120	180	
3GN□S	3~18	5	80	120	40
	25~180		150	250	
4GN□S	3~18	8	100	150	50
	25~180		200	300	
5GN□S	3~18	10	250	350	100
	25~180		300	450	
5GU□KB	3~9	20	400	500	150
	12.5~18		450	600	
	25~180		500	700	

■ Permissible Load Inertia of Gearhead: J

When a high load inertia (J) is connected to a gearhead, high torque is exerted instantaneously on the gearhead when starting up in frequent, discontinuous operations (or when stopped instantaneously). Excessive impact loads can cause the gearhead or motor damage. The table below gives values for permissible load inertia on the motor shaft. Use the motor and gearhead within these parameters. The permissible load inertia (J) on the gearhead output shaft is calculated with the following equation.

The life of the gearhead when operating at the permissible inertial load with instantaneous stops of the motors with speed control motors is at least two million cycles.

● Permissible Load Inertia at the Gearhead Output Shaft

$$\begin{aligned} \text{Gear Ratio } 1/3 \sim 1/50 & \quad J_G = J_M \times i^2 & \quad J_G : \text{Permissible load inertia at the motor shaft } J (\times 10^{-4} \text{kg}\cdot\text{m}^2) \\ \text{Gear Ratio } 1/60 \text{ or higher} & \quad J_G = J_M \times 2500 & \quad J_M : \text{Permissible load inertia at the motor shaft } J (\times 10^{-4} \text{kg}\cdot\text{m}^2) \\ & & \quad i : \text{Gear Ratio (Example: } i = 3 \text{ means the gear ratio of } 1/3) \end{aligned}$$

● Permissible Load Inertia at the Motor Shaft

No. of Phase	Motor Frame Size	Output Power	Permissible Load Inertia at the Motor Shaft J ($\times 10^{-4}$ kg·m ²)
Single-Phase	□60 mm	6 W	0.062
	□70 mm	15 W	0.14
	□80 mm	25 W	0.31
	□90 mm	40 W	0.75
		60 W	1.1

Accessories

External Speed Potentiometer RoHS

- Model: **PAVR-20KZ**
(20 kΩ 1/4 W, with a linear resistance vs. angle curve)



Note:
One set of this external potentiometer is included with the **ES01/ES02** speed controllers. The external speed potentiometer is used for control involving multiple speed settings.

- Dimensions (Unit = mm)
Mass: 20 g

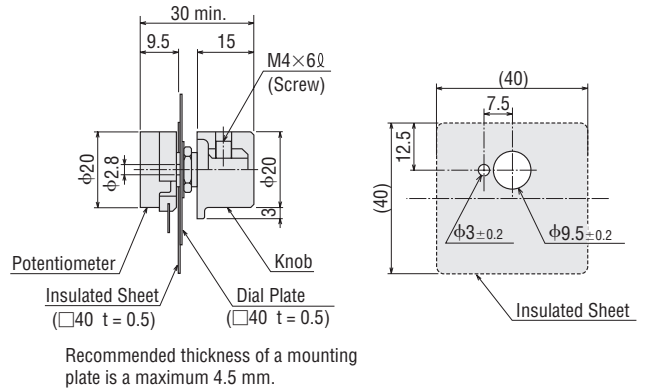

Motor/Gearhead Mounting Brackets RoHS

Mounting Brackets for attaching and securing a motor and gearhead. They are high-strength type, which can be used with high power motors/gearheads. These brackets come with tapped holes. To mount the motor and gearhead, simply fasten with the screws provided to the gearhead.



For motor frame size: 60 mm

- Model: **SOL2M4**
Mass: 135 g Material: Aluminum Alloy
- ◇ Applicable Product
2GN Gearhead
Motor with the frame size of 60 mm

- Dimensions (Unit = mm)

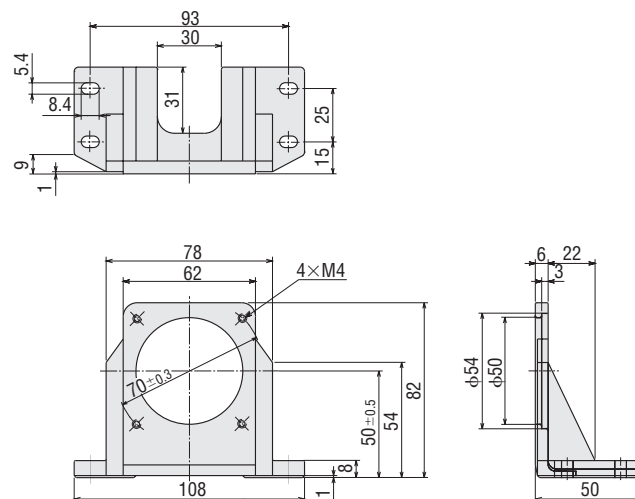

For motor frame size: □ 70 mm

● **Model: SOL3M5**

Mass: 175 g Material: Aluminum Alloy

◇ **Applicable Product**

SOL3M5

3GN Gearhead

Motor with the frame size of □ 70 mm

● **Dimensions (Unit = mm)**

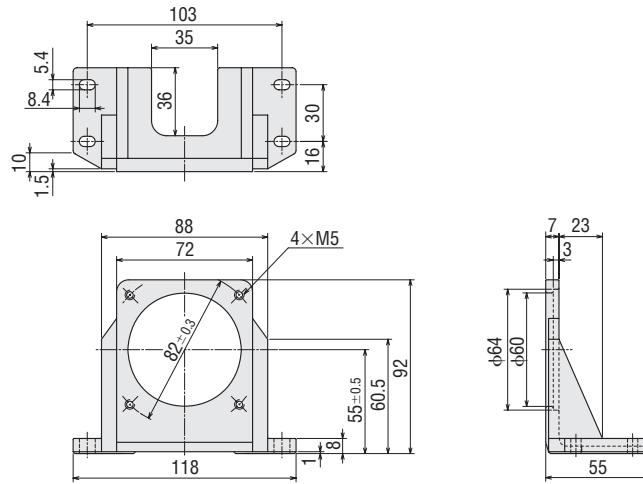

For motor frame size: □ 80mm

● **Model: SOL4M5**

Mass: 210 g Material: Aluminum Alloy

◇ **Applicable Product**

SOL4M5

4GN Gearhead

Motor with the frame size of □ 80 mm

● **Dimensions (Unit = mm)**

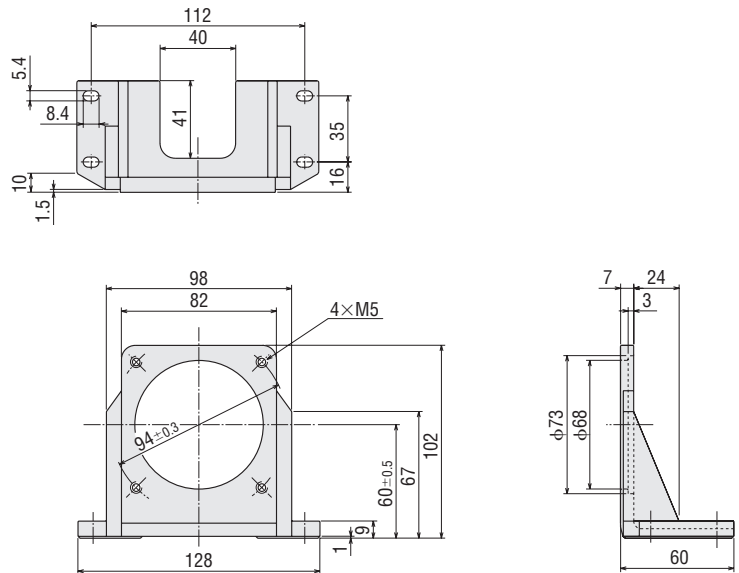

For motor frame size: □ 90 mm

● **Model: SOL5M6**

Mass: 270 g Material: Aluminum Alloy

◇ **Applicable Product**

SOL5M6

5GN Gearhead

5GU□KB Gearhead

Motor with the frame size of □ 90 mm

● **Dimensions (Unit = mm)**

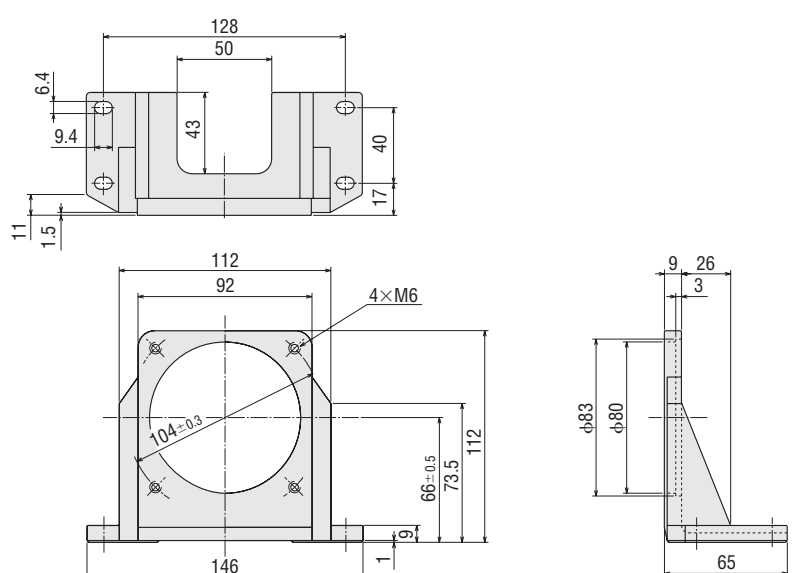

■ CR Circuit for Surge Suppression (RoHS)

This product is used to protect the contacts of the relay and/or switch used for controlling the reversal of direction.



● Model: EPCR1201-2

250 VAC (120 Ω, 0.1 μF)

● Dimensions (Unit = mm)

Mass: 5 g

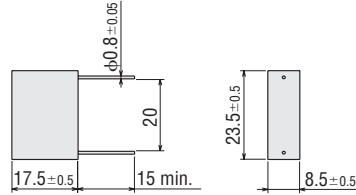

■ Flexible Couplings (RoHS)

These products are the clamping type couplings to connect between the shaft of motor/gearhead and the shaft of the equipment to be connected.

Once the motor and gearhead are determined, the coupling can be selected.



● Features

- Couplings come with shaft holes and have standardized combinations for different diameter shaft holes.
- Characteristics are the same for clockwise and counterclockwise rotation.
- Oil-resistant and electrically insulated.
- Aluminum alloy construction.
- The shaft being driven is not damaged, since shafts are joined by clamping.
- Easy installation due to a separated hub and sleeve design.

Gearhead Model	Coupling Type
2GN□S	MCL20
	MCL30
3GN□S	MCL30
4GN□S	MCL30
	MCL40
5GN□S	MCL30
	MCL40
5GU□KB	MCL40
	MCL55

* Type of coupling varies depending on condition of the load.

Orientalmotor

This product is manufactured at a plant certified with the international standards **ISO 9001** (for quality assurance) and **ISO 14001** (for systems of environmental management).

Specifications are subject to change without notice.
This catalogue was published in April, 2007.

ORIENTAL MOTOR (EUROPA) GmbH

www.orientalmotor.de

European Headquarters and Düsseldorf Office

Schiessstraße 74
40549 Düsseldorf, Germany
Tel: 0211-5206700 Fax: 0211-52067099

Munich Office

Liebigstraße 14
85757 Karlsfeld, Germany
Tel: 08131-59880 Fax: 08131-598888

Hamburg Office

Meckelfelder Weg 2
21079 Hamburg, Germany
Tel: 040-76910443 Fax: 040-76910445

Jena Office

Wildenbruchstr 15
07745 Jena, Germany
Tel: 03641-675280 Fax: 03641-675288

Stuttgart Office

Tel: 07335-924853 Fax: 07335-924854

Customer Center (Support in German & English)

00800 22 55 66 22*
CALL OM CC

tech@orientalmotor.de

ORIENTAL MOTOR (UK) LTD.

www.oriental-motor.co.uk

Unit 5, Faraday Office Park,
Rankine Road, Basingstoke,
Hampshire RG24 8AH U.K.
Tel: 01256-347090 Fax: 01256-347099

ORIENTAL MOTOR (FRANCE) SARL

www.orientalmotor.fr

France Headquarters

32, Avenue de l'île Saint Martin
92737 Nanterre Cedex, France
Tel: 01 47 86 97 50 Fax: 01 47 82 45 16

Lyon Office

10, Allée des Sorbiers
69673 Bron Cedex, France
Tel: 04 78 41 15 02 Fax: 04 78 41 15 90

ORIENTAL MOTOR ITALIA s.r.l.

www.orientalmotor.it

Italy Headquarters

Via A. De Gasperi, 85
20017 Mazzo di Rho (MI), Italy
Tel: 02-93906346 Fax: 02-93906348

Bologna Office

Via mori, 6
40054 Prunaro di Budrio (BO), Italy
Tel: 051-6931249 Fax: 051-6929266

ORIENTAL MOTOR CO., LTD.

www.orientalmotor.co.jp

Headquarters

16-17, Ueno 6-chome
Taito-ku, Tokyo 110-8536, Japan
Tel: (03)3835-0684 Fax: (03)3835-1890

For more information please contact:



This printed material uses recycled paper and soy inks. This combination is environmentally friendly.